

Water Heater Unit

Upgrading Auxiliary Heater

Thermo Top V 
00 0018

Installation Instructions

VW Passat

Diesel
from Model Year 2005
For left-hand drive vehicles only



WARNING!

Hazard warning:

Incorrect installation or repair of Webasto heating systems may cause a fire or result in the emission of carbon monoxide, which can be fatal. Serious or fatal injuries can be caused as a result.

Specialist company training, technical documentation, specialized tools and equipment are required to install and repair Webasto heating and cooling systems.

NEVER attempt to install or repair Webasto heating or cooling systems if you have not successfully completed the company training and thereby acquired the required technical skills, or if you do not have access to the required technical documentation, tools and equipment needed to carry out correct installation and repairs.

ALWAYS follow all Webasto installation and repair instructions and observe all warnings.

Webasto does not accept any liability for defects and damage that are attributable to installation by untrained staff.

Table of Contents

Validity	2
Heater Unit/Installation Kit	3
Foreword	3
General Instructions	3
Special Tools	3
Explanatory Notes on the Document	4
Preliminary Work	5
Heater Unit Installation Location	5
Electrical Connections	6
Climatic Fan Controller	7
Climatronic Fan Controller	10
Remote Option (Telestart)	11
Final Work	13
Operating Instructions for End Customer	14

Validity

Manufacturer	Model	Type	EG-BE No./ABE
Volkswagen	VW Passat	3C	e1 * 2001/116 * 0307 * ...

Engine type	Engine model	Output in kW	Displacement in cm ³
BKC	Diesel	77	1896
BKP	Diesel	103	1968
BMP	Diesel	103	1968

Vehicle and engine types, equipment variants and national specifications not listed in these installation instructions have not been tested. However, installation according to these installation instructions may be possible.

The installation location of a digital timer and summer/winter switch should be confirmed with the end customer before installation.

Heater Unit/Installation Kit

Quantity	Description	Order No.:
1	Upgrade kit for VW Passat Climatronic	9013729E
1	Upgrade kit for VW Passat Climatic	9013728D

Also required:

1	Digital timer kit	1301122C
---	-------------------	----------

and/or

1	Telestart T80 advanced kit	9007098A
---	----------------------------	----------

Other required tools:

Vehicle	Heater unit
PC USB diagnosis	9009064C
Upgrade kit for Touran	9008996A

Attention

No heater control is included in the delivery scope. The desired heater control must be ordered separately.

Foreword

These installation instructions apply to VW Passat Diesel vehicles with an auxiliary heater installed as standard equipment

- For the validity, see page 2 - from model year 2005 and later, assuming technical modifications to the vehicle do not affect installation, any liability claims excluded. Depending on the vehicle version and equipment, modifications may be necessary during installation with respect to these installation instructions.

However, the stipulations in the "installation instructions" and "operating and maintenance instructions" for the *Thermo Top C/P/E* must always be observed.

The corresponding rules of technology and any information from the vehicle manufacturer should be observed during the installation work.

General Instructions

Installation should be carried out according to the general, standard rules of technology. Unless specified otherwise, fasten hoses, lines and wiring harnesses to original vehicle lines and wiring harnesses using cable ties.

Sharp edges should be fitted with edge protectors (split-open plastic hose).

Spray unfinished body areas, e.g. drilled holes, with anti-corrosion wax (Tectyl 100K, Order No. 111329).

Special Tools

- Computer with MS Windows operating system
- Webasto diagnosis adapter

Explanatory Notes on Document

To provide you with a quick overview of the individual working steps, you will find an identification mark on the outside top right corner of the page in question.

Mechanical work

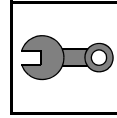

Electrical system

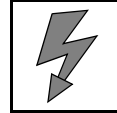

Special features are highlighted using the following symbols:



Specific risk of injury or fatal accidents.



Specific risk of damage to components.



Specific risk of fire or explosion.



Reference to general installation instructions of Webasto components or to the manufacturer's vehicle-specific documents.



Reference to a special technical feature.

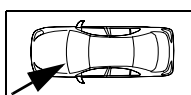
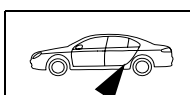

The arrow in the vehicle icon indicates the position on the vehicle and the viewing angle.

Preliminary Work

WARNING!

- Disconnect the battery "earth" or "ground" connection.
- Completely remove the battery.
- Remove the battery carrier.
- Copy the factory number from the original type label to the duplicate type label.
- Remove years that do not apply from the duplicate label.
- Attach the duplicate label (type label) in the appropriate place.
- Remove the fuse and relay carrier.
- Remove the bumper.
- With Climatronic, remove the radio or navigation system cover.
- With Climatronic, remove the A/C control panel.

Please remove page 15 "Operating instructions for the end customer" and add this to the operating instructions.

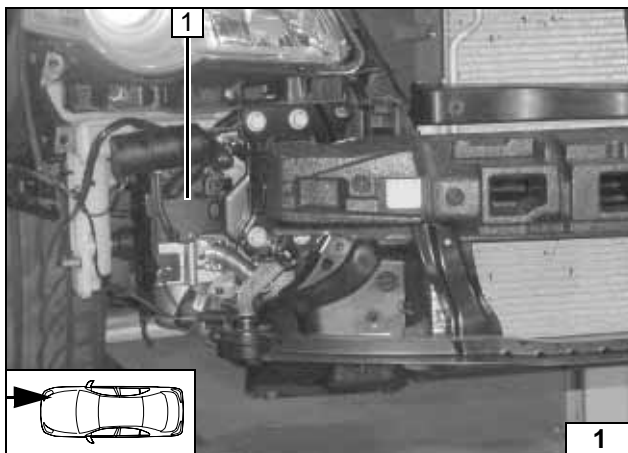

Heater unit installation location

- 1 Heater unit

Installation location



Electrical Connections



Wiring harness pass through

Wiring routing

1 Protective rubber plug

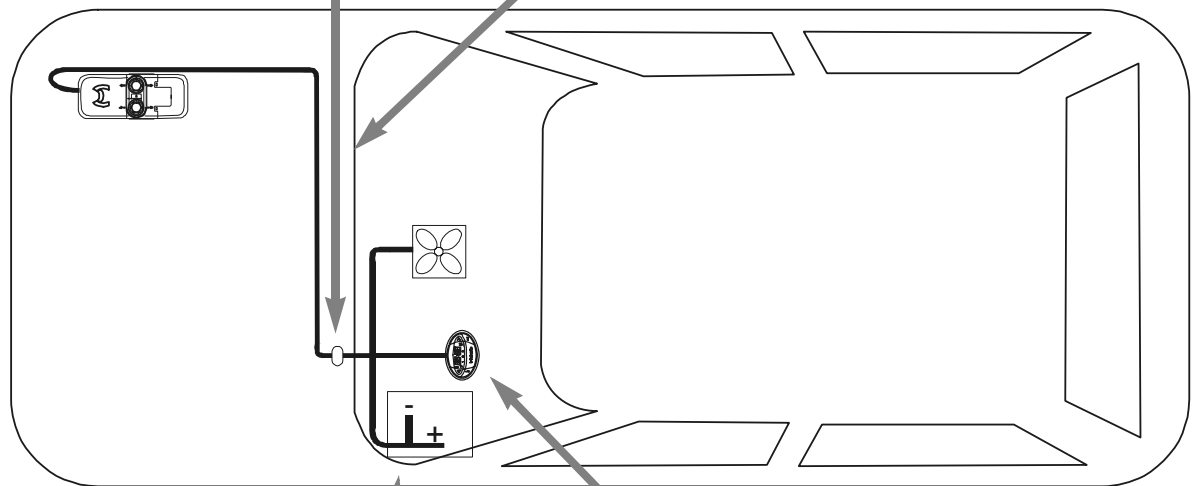
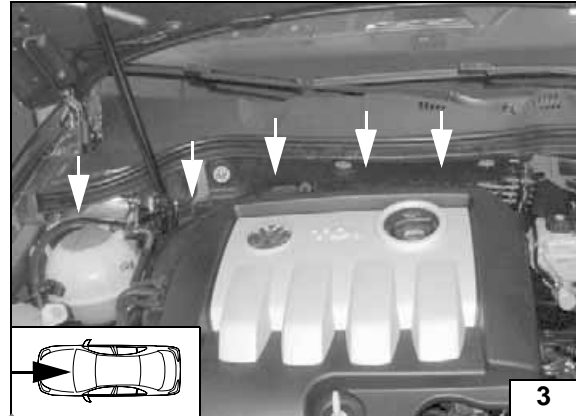
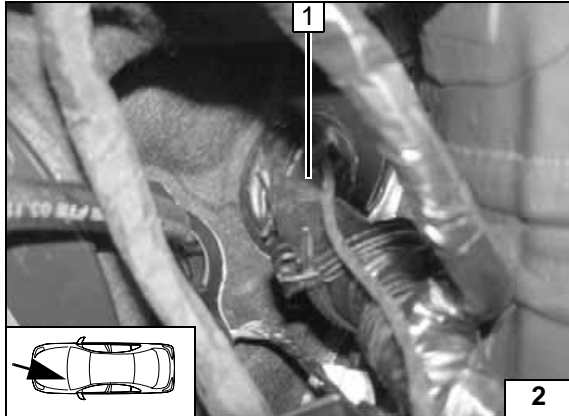

Wiring harness installation diagram

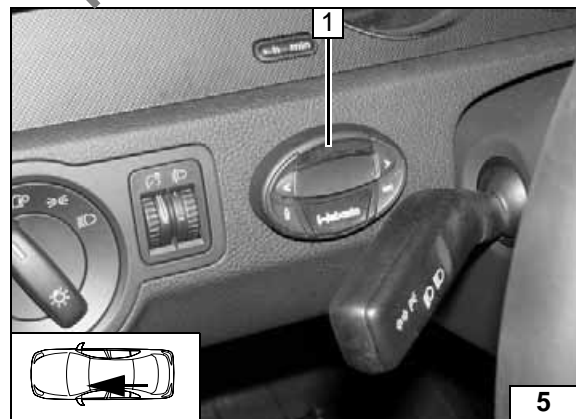
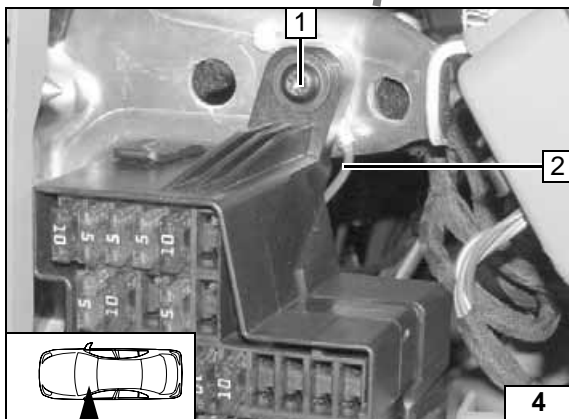

Ground connection

Digital timer

- 1 Original vehicle bolt
- 2 Ground wire

- 1 Digital timer

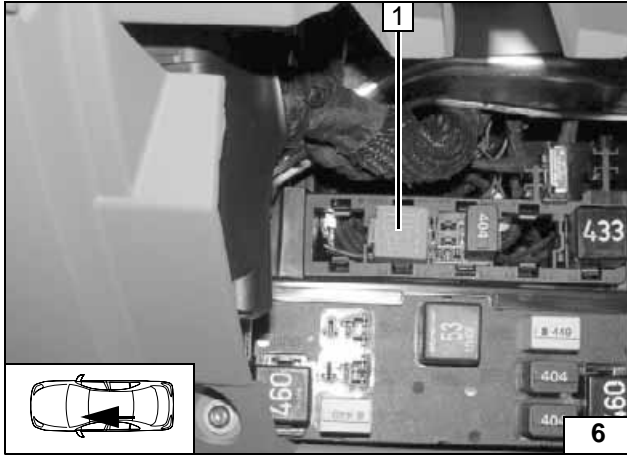

Climatic fan controller

Produce connections as shown in wiring diagram.
Position of free sockets dependent on equipment variant.

- 1 Relay K3

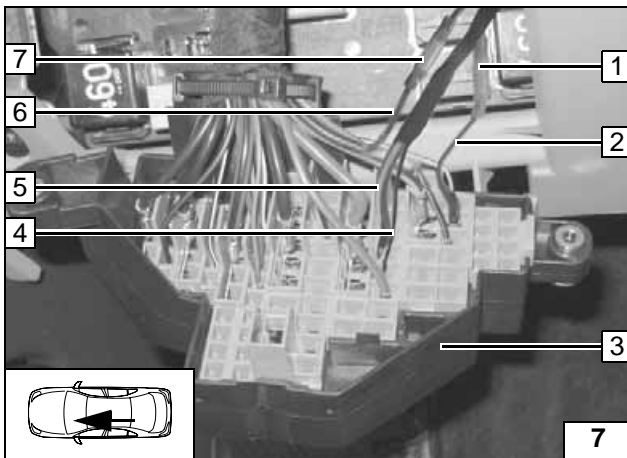

Installing K3 relay



Produce connections as shown in wiring diagram.

- 2 Red/black (rt/sw) wire from fuse slot 41
- 6 Red/black (rt/sw) wire to A/C control panel
- 1 Connector with red (rt) wire from K3/87a
- 7 Connector with black (sw) wire to K3/30
- 5 Mount red/yellow (rt/ge) wire in socket 36 or free socket (terminal 30) if necessary, 40 A fuse
- 4 Black/red (sw/rt) wire in socket 35 or free socket (terminal 30) if necessary
- 3 Mount fuse carrier, 1 A fuse

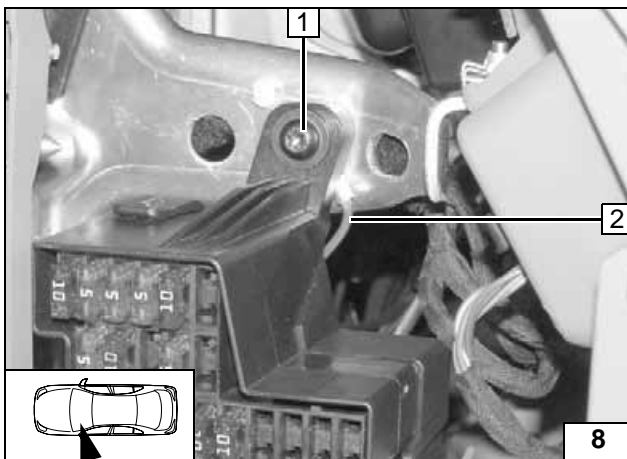

Connecting fuse carrier



Screw on ground cable between fuse carrier and instrument panel bracket with original vehicle bolt.

- 1 Original vehicle bolt
- 2 Ground wire

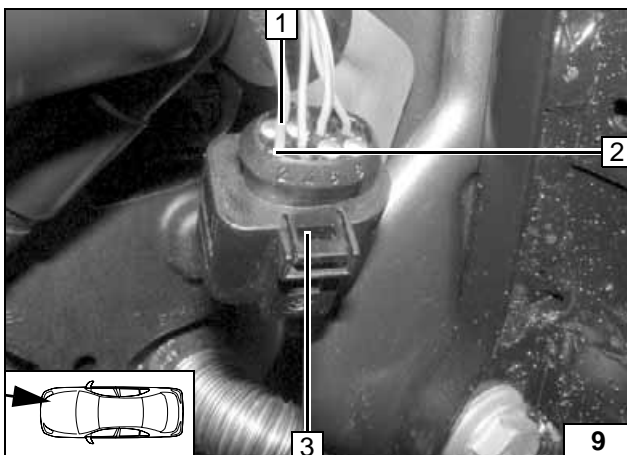
Ground connection



- 2 Remove sealing plug (chamber 2)
- 1 Yellow (ge) wire
- 3 8-pin connector to heater unit

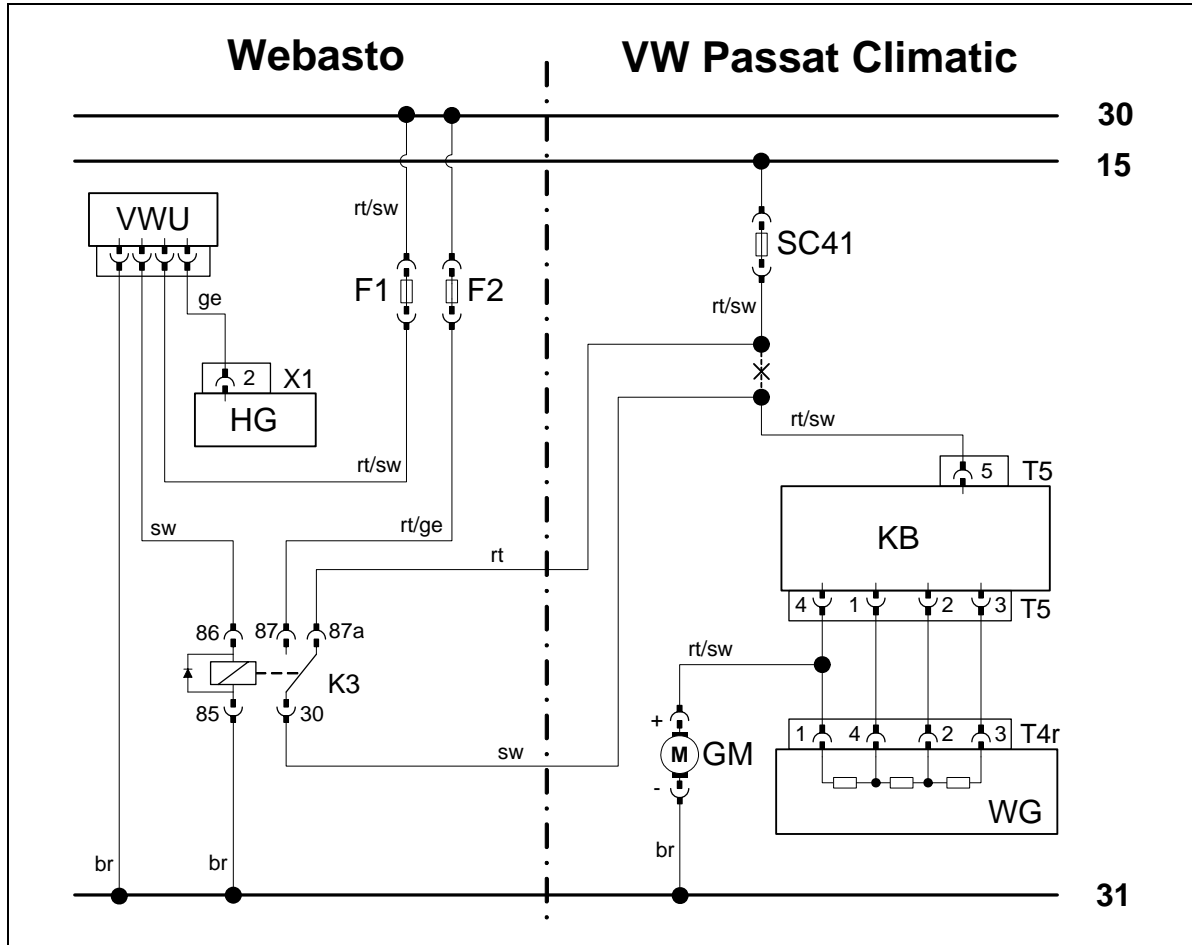

Control of heater unit



Climatic wiring diagram

Webasto components		VW Passat components		Colors and symbols	
HG	TT-V heater unit	SC41	40 A fan fuse	rt	red
X1	6-pin connector	KB	Control unit for air conditioning - J301	ws	white
F1	1 A fuse	WG	Resistor group - N24	sw	black
F2	Fuse 40A	GM	Fan motor - V2	br	brown
K3	Fan relay	T....	Plug connections	ge	yellow
VWU	Digital timer				
				X	Cutting point

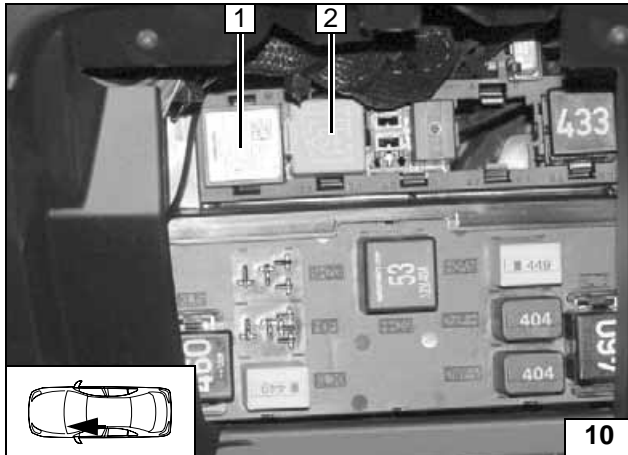
Legend



Climatronic fan controller

Produce connections as shown in wiring diagram.

- 1 Relay IPCU
- 2 K3 relay

Installing IPCU module, K3 relay

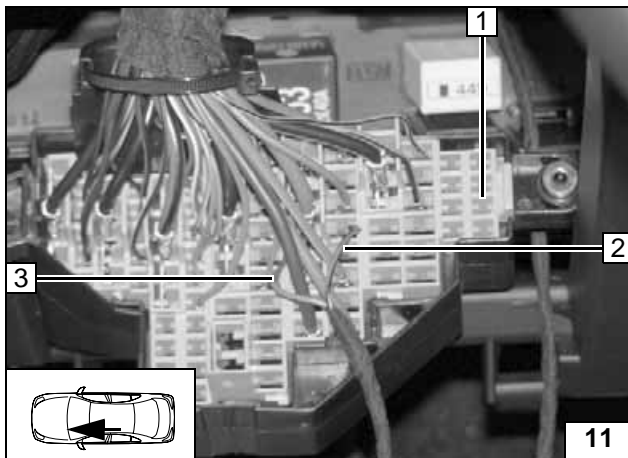

Integrating on fuse holder.

Produce connections as shown in wiring diagram.

- 1 Fuse holder
- 2 Mount red/black (rt/sw) wire in socket 35 or free socket (terminal 30) if necessary, 1 A fuse
- 3 Mount blue (bl) wire in socket 25 or free socket (terminal 15) if necessary, 1 A fuse

Connecting fuse carrier

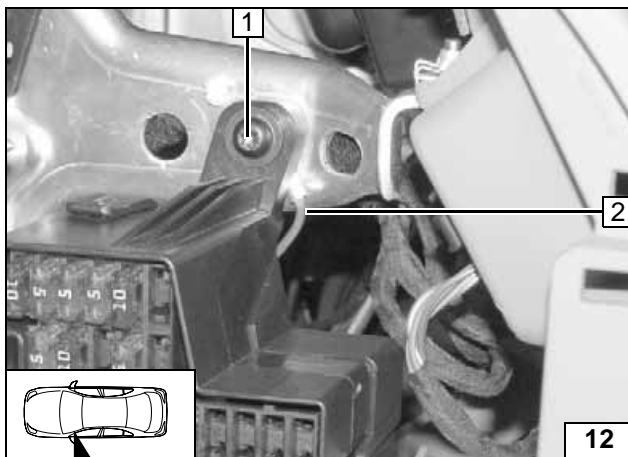

Fasten ground wire 2 between fuse carrier and instrument panel bracket with original vehicle bolt 1.

Connecting ground wire

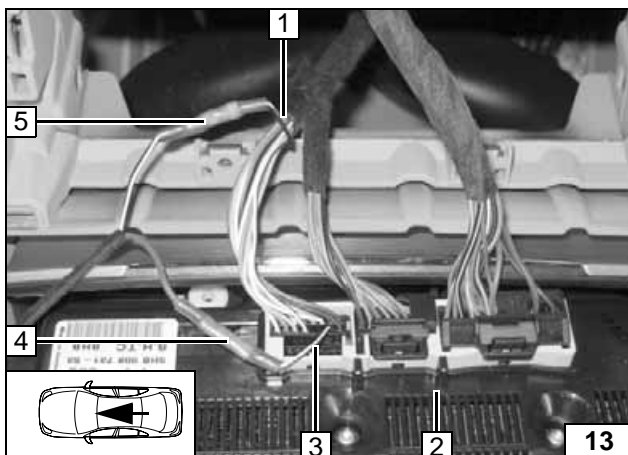

Integrating on connector T16f from A/C control panel 2.

Produce connections as shown in wiring diagram.

- 1 Black/white (sw/ws) wire to fan unit
- 3 Black/white (sw/ws) wire to connector T16f
- 5 Connector with black (sw) wire from IPCU/A
- 4 Connector with red (rt) wire to IPCU/E

Connecting air-conditioning control element



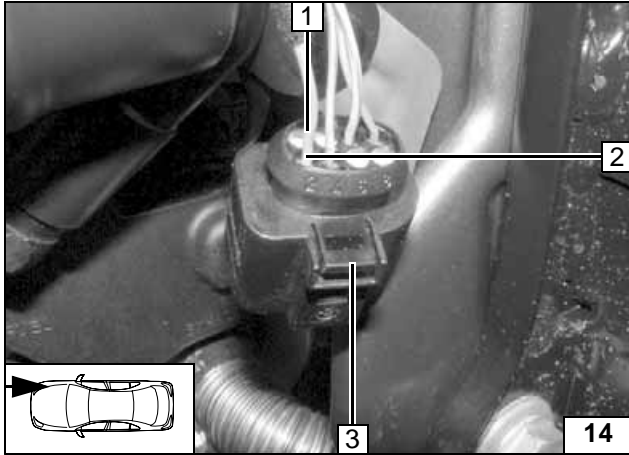

- 2 Remove sealing plug (chamber 2)
- 1 Yellow (ge) wire
- 3 8-pin connector to heater unit



Control of heater unit

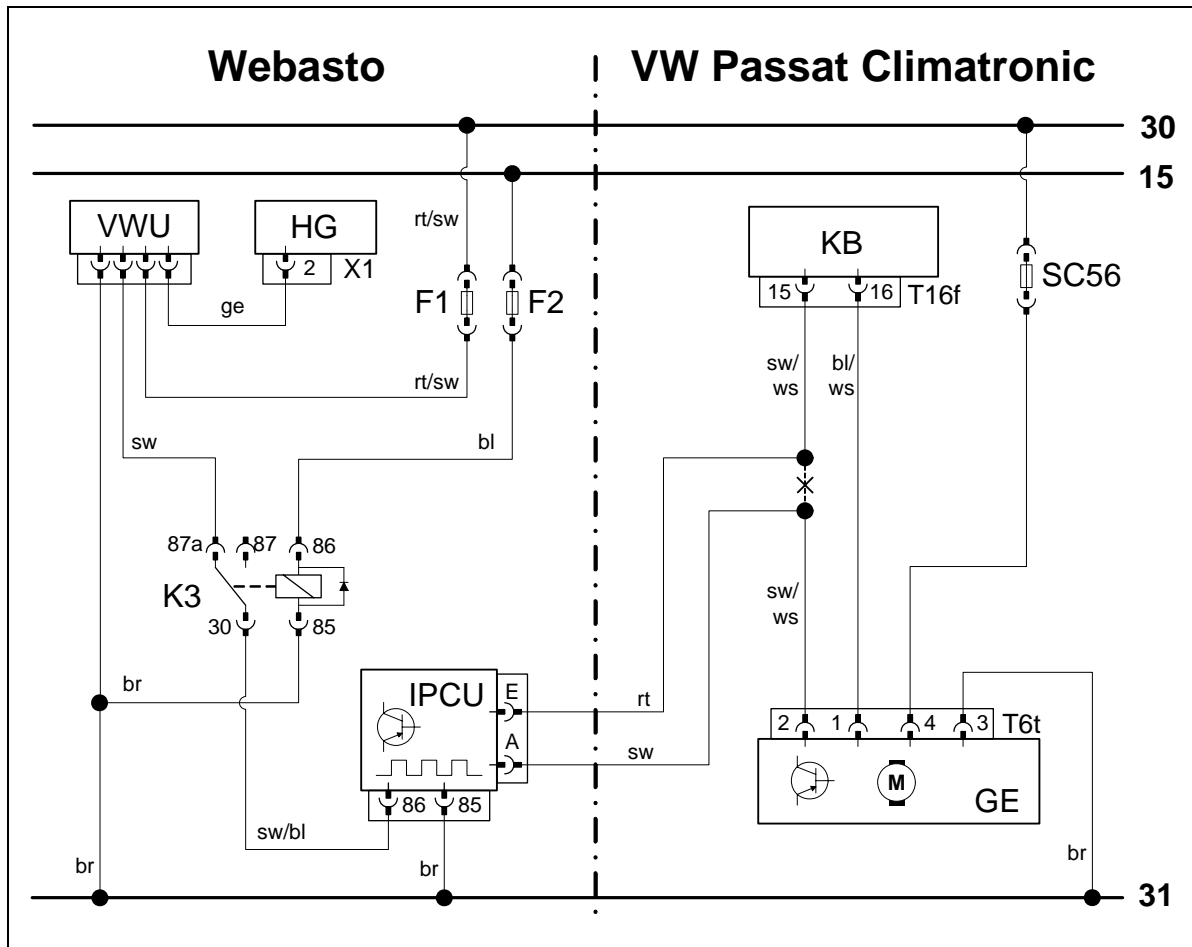

Clima-
tronic
wiring
diagram

Webasto components		VW Passat components		Colors and symbols	
HG	TT-V heater unit	SC56	Fuse 40A	rt	red
X1	6-pin connector	KB	Climatronic control unit - J255	ws	white
F1	1 A fuse			sw	black
F2	1 A fuse	T...	Plug connections	br	brown
K3	Fan relay	ge	Fan control unit - J126 and fan motor - V2	gn	green
VWU	Digital timer			bl	blue
				ge	yellow
				X	Cutting point

Legend

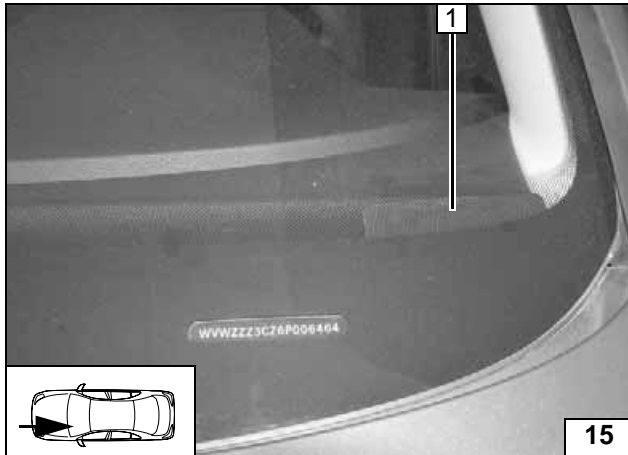

Remote option (Telestart)

Route antenna cable to duct behind relay carrier.

1 Antenna on windshield



Installing antenna

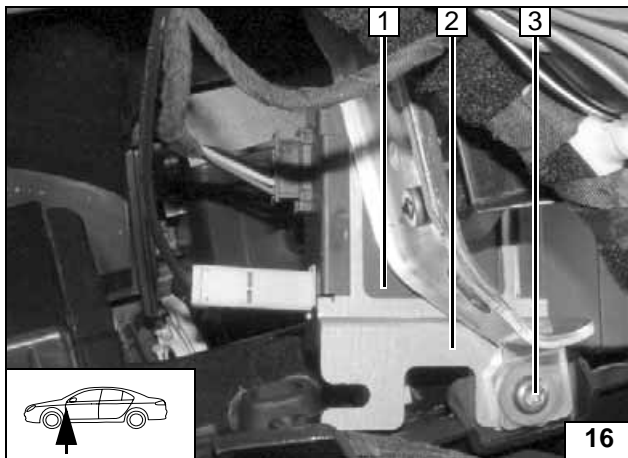

Position bracket of receiver 2 over fuse holder and fasten with original vehicle bolt 3.

1 Receiver



Installing receiver

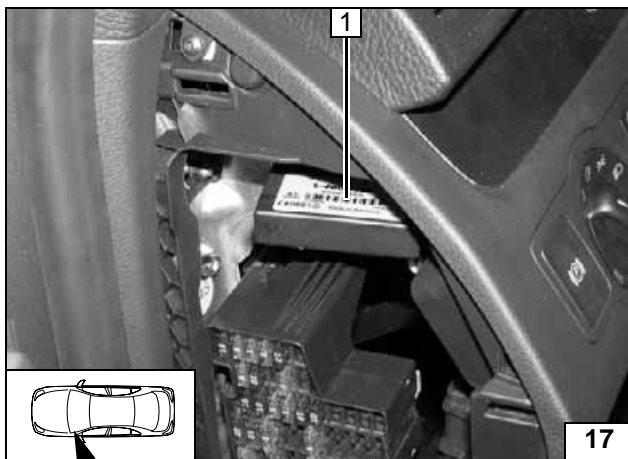

1 Receiver of radio remote control

Positioning receiver

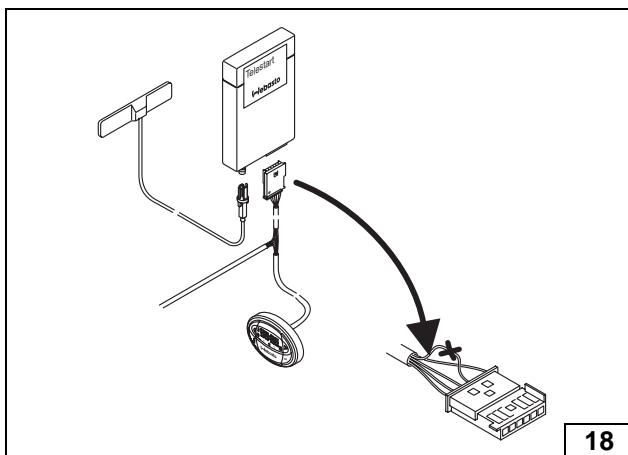

Connect antenna cable to receiver of radio remote control.
When simultaneously integrating digital timer 1533, black (sw) wire, 0.5 mm², on socket, Pin 3, must be cut off and insulated approx. 50 mm before connector of Telestart.
Connect wiring harness on receiver of radio remote control.



Installing receiver

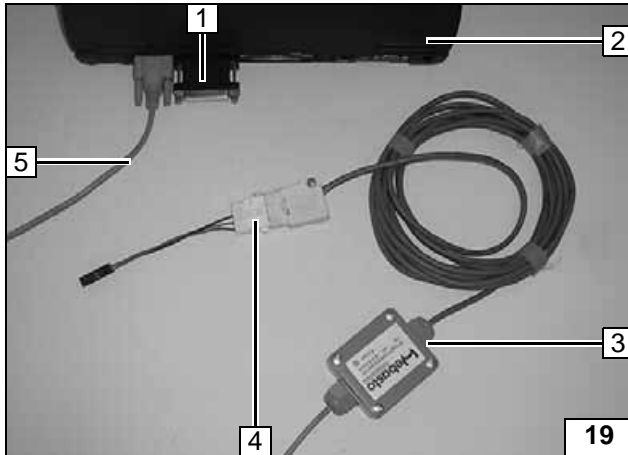

To establish communication to heater control unit, an unassigned serial or USB port must be used.

- 1 Dongle
- 2 Laptop
- 3,5 Diagnosis adapter (serial version shown)
- 4 Plug adapter



Installing software

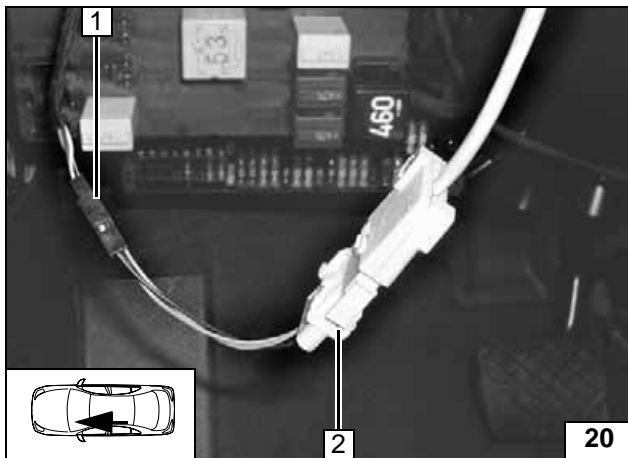

- 1 Connector of wiring harness of digital timer
- 2 Plug adapter

Connecting connector

Read *Readme file* carefully before upgrading!

Starting from Windows Explorer.

- Start upgrade program with
- "Upgrade.exe"
- Select language
- Follow menus

Starting with CD.

- Insert CD
- Select language
- Follow menus

Installing upgrade

Disconnect connection after message "*Upgrade successful*".

When installing the software, the fuel level in the tank must be above the "Reserve" level.



If the radio remote control option is not installed, the following message may appear during future diagnosis:

"*W-bus communication: faulty*"
This message can be ignored!

Note on software update



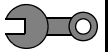

Final Work

WARNING!

Apply the warranty sticker in an easily visible location on the relay carrier bracket.
Reassemble the disassembled components in reverse order.
Check all electrical connections for firm seating.
Secure all loose cables using cable ties.

- Connect the battery.
- Set the digital timer and/or teach Telestart.
- Adjust the vehicle heater with Climatronic or Climatic according to "Operating Instructions for End Customer".
- Check the proper operation of the additional heater, see the operating instructions/installation instructions.
- Attach the "Switch off additional heater before refueling" sticker to the left-hand B-pillar.

Adjustment of passenger compartment monitoring with VAG5052 Tester.

The following steps must be carried out with the VAG Tester :

- Connect the VAG tester.
- Open Item 46 (Central Module of Comfort System)
- Go to Item 10 (Adjustment)
- Follow the request for the code entry and enter the code 15
- Reduce the sensitivity of the passenger compartment monitoring to 50 %
- Save this setting

The adjustment of the sensitivity of the passenger compartment monitoring is completed.



Webasto

Feel the drive

Webasto AG
Postfach 80 - 82132 Stockdorf, Germany - Hotline +49-
(0)1805-932278
Hotfax +49-(0)395-5592-353 - <http://www.webasto.de>

Operating Instructions for End Customer

Please remove page and add to the vehicle operating instructions.

To ensure proper operation of the additional heater, the fuel level in the tank must be above the "Reserve" level.

The sensitivity of the passenger compartment monitoring has been reduced.

Before parking the vehicle, make the following settings:

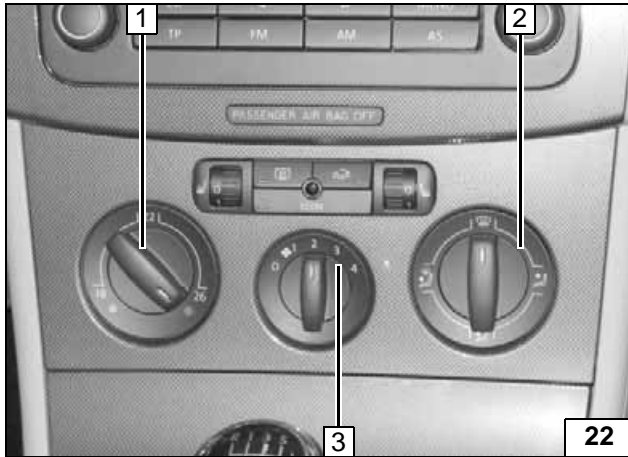

- 1 Set temperature to "max."
- 2 Air outlet to windshield
- 3 Set fan to level "1", or possibly "2"

Climatic

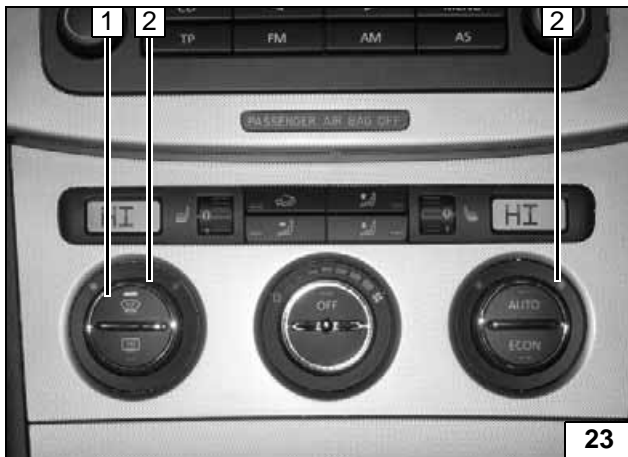

- 1 Air outlet to windshield
- 2 Set temperature to "max."

Clima-
tronic