

Water heater unit



Thermo Top E Additional heating

00 0003

Thermo Top C Additional heating

00 0002

Thermo Top P Additional heating

00 0104

Installation instructions

Toyota Prius

Petrol

From model year 2006

For left-hand drive vehicles only



WARNING!

Hazard warning:

Incorrect installation or repair of Webasto heating systems may cause a fire or result in the emission of carbon monoxide, which can be fatal. Serious or fatal injuries can be caused as a result.

Specialist company training, technical documentation, specialized tools and equipment are required to install and repair Webasto heating and cooling systems.

NEVER attempt to install or repair Webasto heating or cooling systems if you have not successfully completed the company training and thereby acquired the required technical skills or if you do not have access to the required technical documentation, tools and equipment needed to carry out correct installation and repairs.

ALWAYS follow all Webasto installation and repair instructions and observe all warning instructions.

Webasto does not accept any liability for defects and damage that are attributable to an installation by untrained staff.

Table of Contents

Validity	2	Preparing the Installation Location	11
Heater Unit / Installation Kit	3	Preparing the Heater Unit	12
Foreword	3	Installing the Heater Unit	12
General Instructions	3	Water Connection	13
Special Tools	3	Fuel Connection	17
Explanatory Notes on the Document	4	Exhaust System	20
Preliminary work	5	Combustion Air	22
Heater unit installation location	5	Final Work	23
Preparing the Electronics	6	Operating instructions for the end customer	24
Electrical Connections	7	Tank Extracting Device Template	25
Air conditioning blower control	8		
Remote Start Option	10		

Validity

Manufacturer	Model	Type	EG-BE No. / ABE
Toyota	Prius	NHW 20	e11 * 2001 / 116 * 0200 * ...

Engine type	Engine model	Power in kW	Engine capacity in cm ³
1NZ-FXE	Petrol	57	1497

Vehicle and engine types, equipment variants as well as national specifications, which are not listed in these installation instructions, have not been tested. Installation according to these installation instructions may, however, be possible.

The installation location of a time switch and summer / winter switch should be confirmed with the end customer before installation.

Heater Unit / Installation Kit

Amount	Description	Order no.:
1	Commercial supply of required control	See price list
1	Installation kit for Toyota Prius Petrol	1311580A

Recommended heater unit for the relevant vehicle class:

Vehicle	Heater unit
Compact car	Thermo Top E
Mid-class, station wagon	Thermo Top C
Luxury, van, off-roader	Thermo Top P

The choice of heater unit is based on the size of the vehicle passenger compartment and the customer's comfort requirements.



Foreword

These installation instructions apply to Toyota vehicles with Prius Petrol – validity, see page 2 – from model year 2006 and later, assuming technical modifications to the vehicle do not affect installation, any liability claims excluded. Depending on the vehicle version and equipment, modifications may be necessary during installation with respect to these installation instructions.

However, the stipulations in the "installation instructions" and "operating and maintenance instructions" for the *Thermo Top C/P/E* are to be observed in any event.

The corresponding rules of technology and any information from the vehicle manufacturer should be observed during the installation work.

General Instructions

Installation should be carried out according to the general, standard rules of technology. Unless specified otherwise, fasten hoses, lines and cable harnesses to original vehicle lines and cable harnesses using cable clips.

Sharp edges should be fitted with edge protectors (split open plastic hose).

Spray unfinished body areas, such as bore holes, with anti-corrosion wax (Tectyl 100K, Order no. 111329).

Special Tools

- Torque spanner for 2.0 - 10 Nm
- Vice-grip wrench
- Riveting nut tool

Explanatory Notes on the Document

To provide you with a quick overview of the individual working steps, you will find an identification mark on the outside top right corner of the page in question.

Mechanics

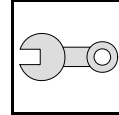

Electrics

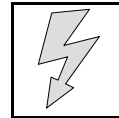

Water connection

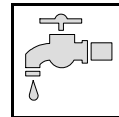

Fuel connection

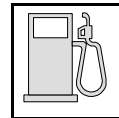

Exhaust System

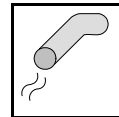

Combustion air

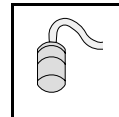

Special features are highlighted using the following symbols:



Specific risk of injury or fatal accidents.



Specific risk of damage to components.



Specific risk of fire or explosion.



Reference to general installation instructions of Webasto components or to the manufacturer's vehicle-specific documents.



Reference to a special technical feature.

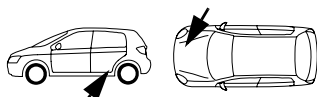

The arrow in the vehicle icon indicates the position on the vehicle and the viewing angle.

Preliminary work

WARNING!

- Open the tank cap, ventilate the tank.
- Close the tank cap again.
- Disconnect the battery.
- Let off pressure in the cooling system.
- Copy the factory number from the original type label to the duplicate type label.
- Remove years that do not apply from the duplicate label.
- Attach the duplicate label (type label) in the appropriate place.
- Dismantle the windshield wipers.
- Completely remove the cooling water reservoir cover.
- Remove the left wheel-house panel.
- Remove the bumper cover.
- Remove the left headlight.
- Remove the front underride protection.
- Remove the rear underride protection (rear fuel line covers).
- Remove the rear seat bench.
- Open the tank mounting service lid
- Remove tank mounting according to manufacturer's instructions.
- Remove the footwell panel on the passenger side.
- Remove the lower center middle console.

Remove page 24 "Operating instructions for the end customer" and insert with vehicle operating instructions.

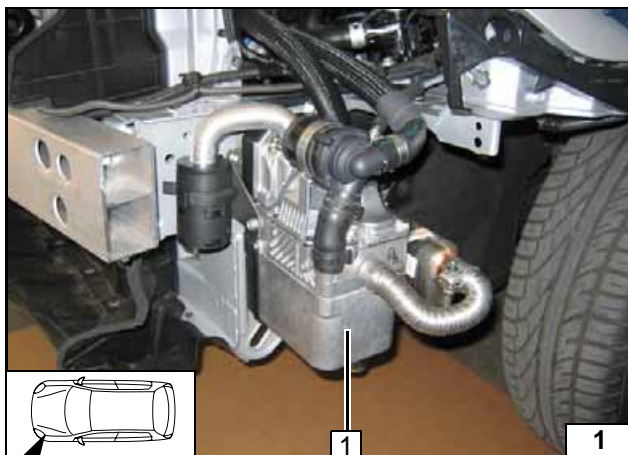

Heater unit installation location

1 Heater unit

Installation location



Preparing the Electronics

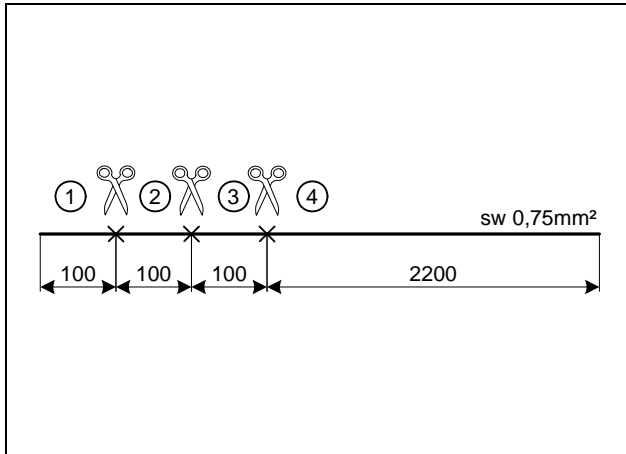

Cutting wires into sections

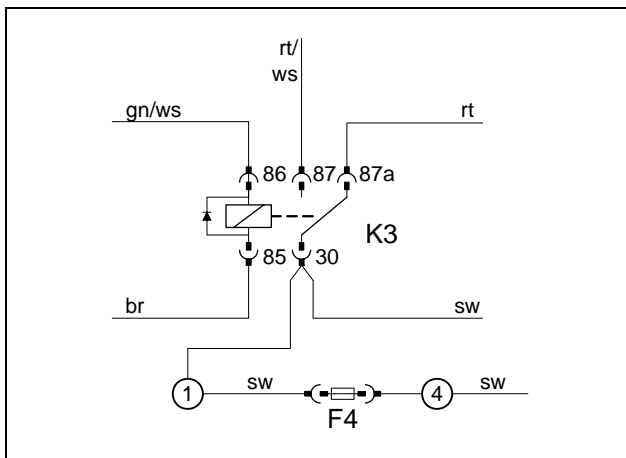

Reconnect according to the circuit diagram. Insert wire section 2 in the enclosed insulating hose.



Preparing fuse F4



Electrical Connections

Cable harness feed-through

- 1 Protective rubber sleeve

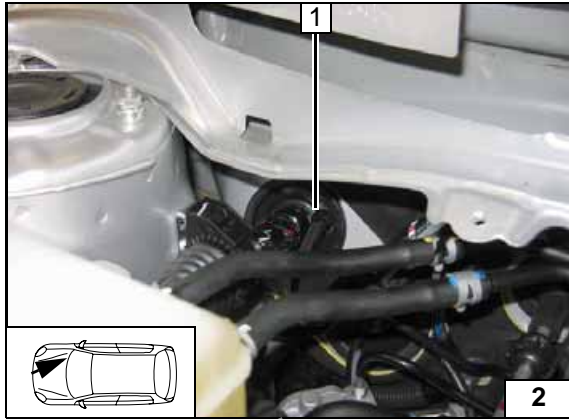

Summer / winter switch option

- 1 Summer / winter switch, bore hole Ø 12 mm.

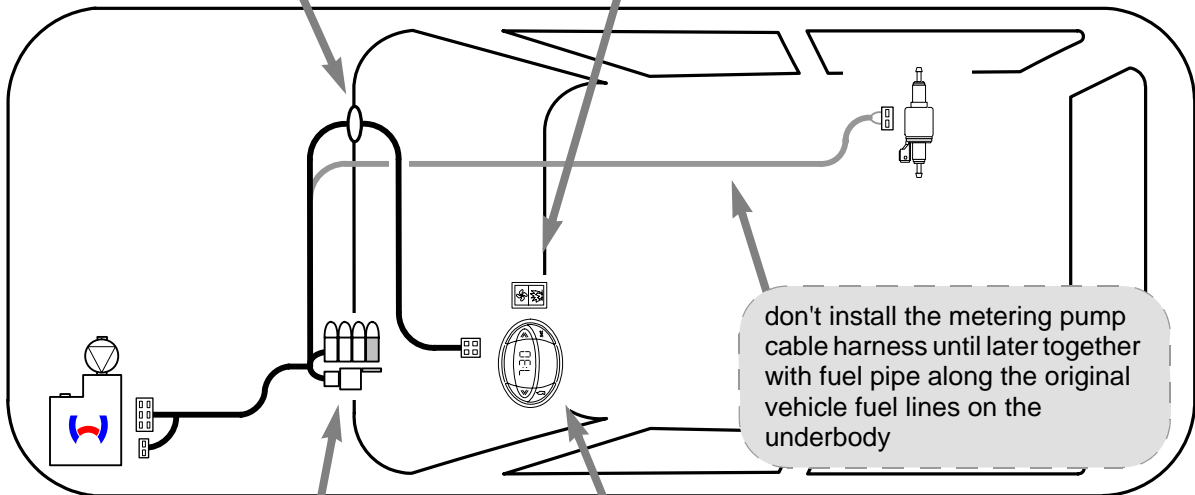
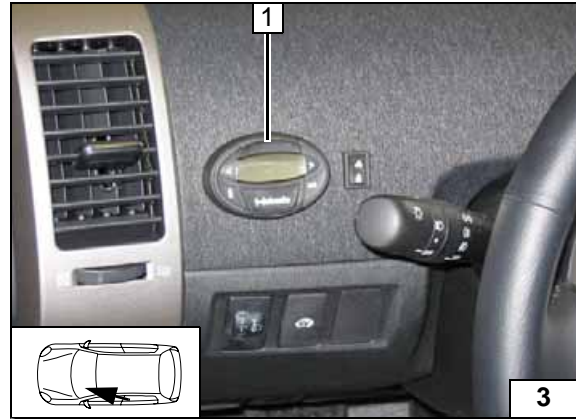

Cable harness installation diagram

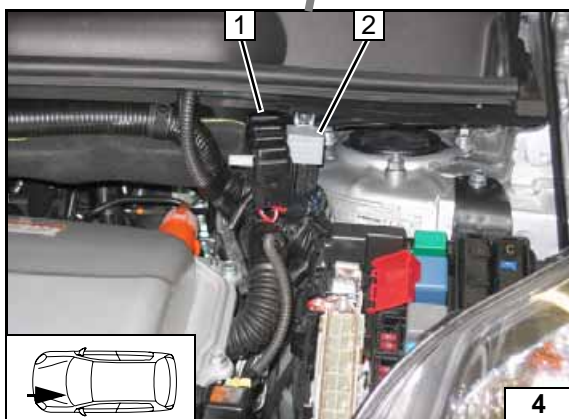

fuse holder, K3 relay

Remove the fuse holder 1 and K3 relay 2 at the installation location only and run the cable harnesses. The fuse holder 1 and the K3 relay 2 will not be mounted on the cooling water reservoir until end (see the final work).



Time switch

- 1 Time switch



Air conditioning blower control

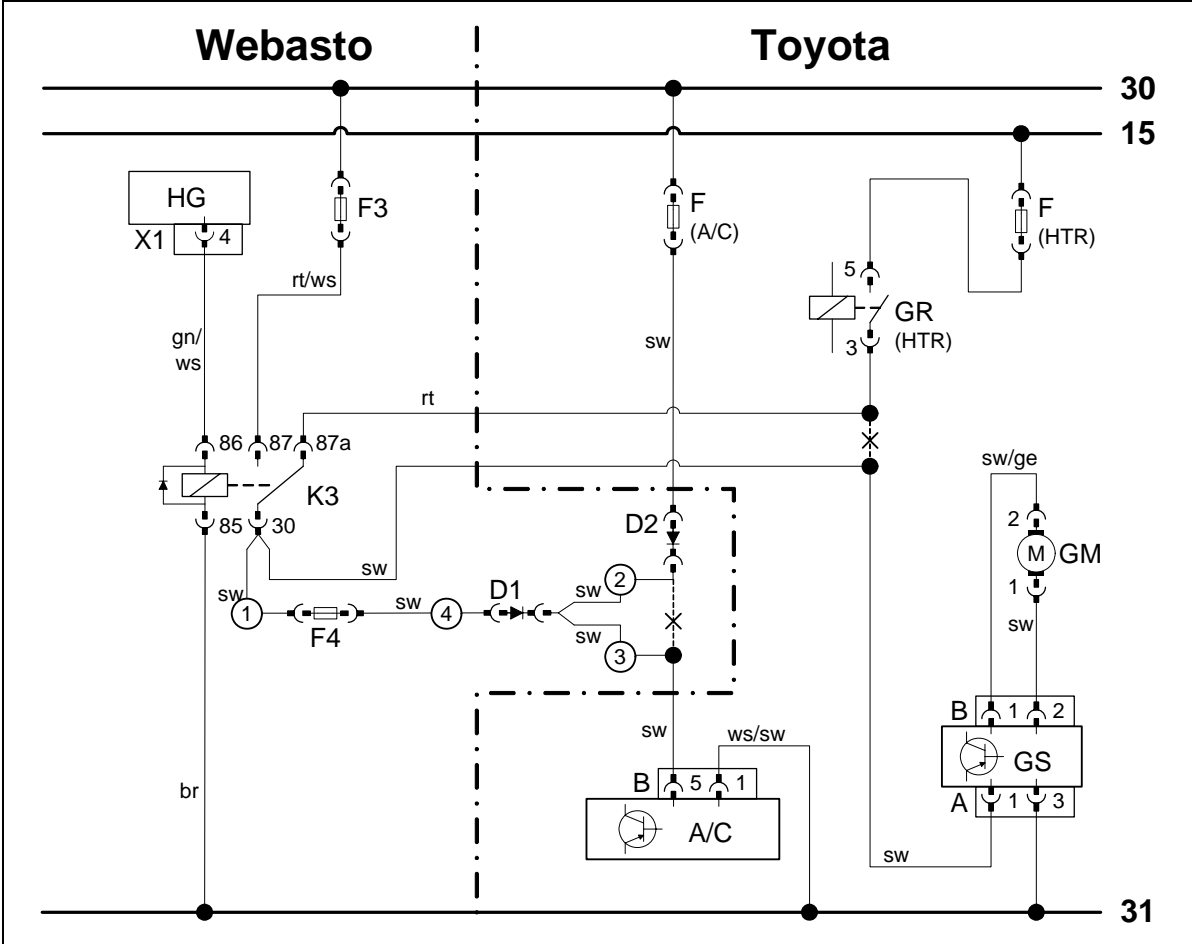

Circuit diagram

Webasto components		Vehicle components		Colours and symbols	
HG	heater unit TT-C/E	GM	blower motor	rt	red
X1	6-pin connector	GS	GM controller	ws	white
F3	Fuse 25A	GR	blower relay	sw	black
F4	Fuse 10A	A/C	A/C controller	br	brown
K3	blower relay	F(A/C)	Fuse 10A	gn	green
D1	Diode 1A	F(HTR)	Fuse 40A	ge	yellow
D2	Diode 1A				
				X	splitting point
				Cable colors may vary.	

Legend

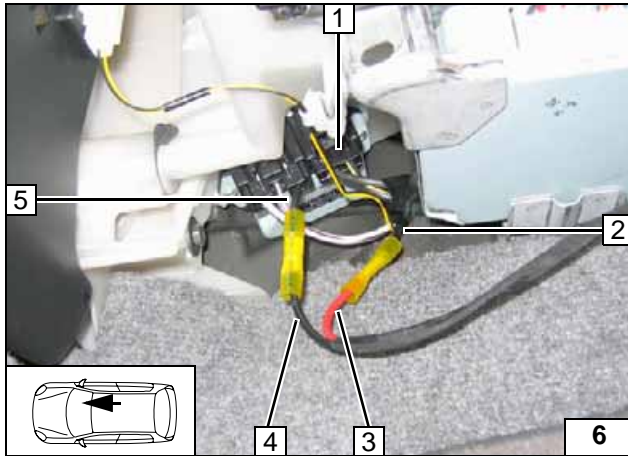

Connection to blower motor 1 controller.
Reconnect according to the circuit diagram.

- 2 Black wire from blower relay
- 3 Red (rt) wire to K3/87a
- 4 Black (sw) wire from K3/30
- 5 Black (sw) wire to connector A pin 1



Connecting the blower motor

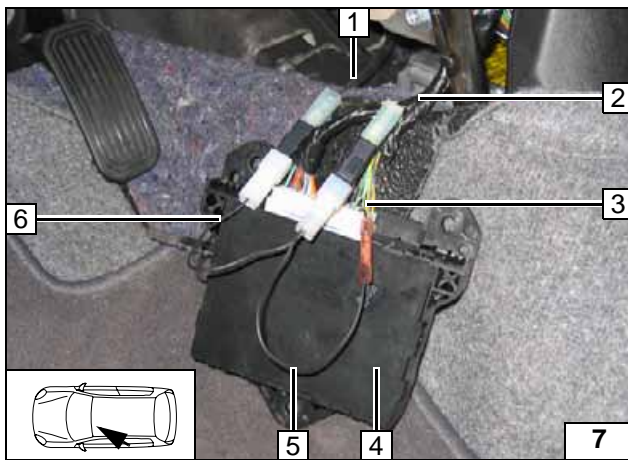

Connection to A/C controller 4.
Reconnect according to the circuit diagram.
Check the current pass direction of the diodes.

- 1 Black (sw) wire from fuse F4 ④
- 2 Black (sw) wire from fuse F(A/C)
- 3 Black (sw) wire to A/C controller connector B pin 5
- 5 Prepared black (sw) ③.
- 6 Prepared black (sw) wire ②.



A/C controller connection

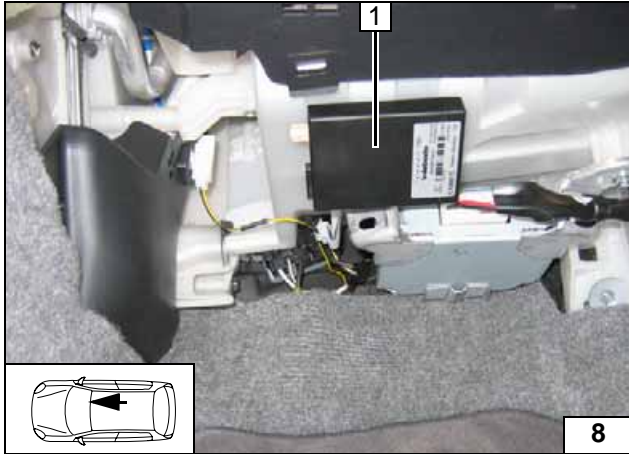

Remote Start Option

Secure the receiver in an appropriate manner (use double-sided adhesive tape).



Assembling the receiver

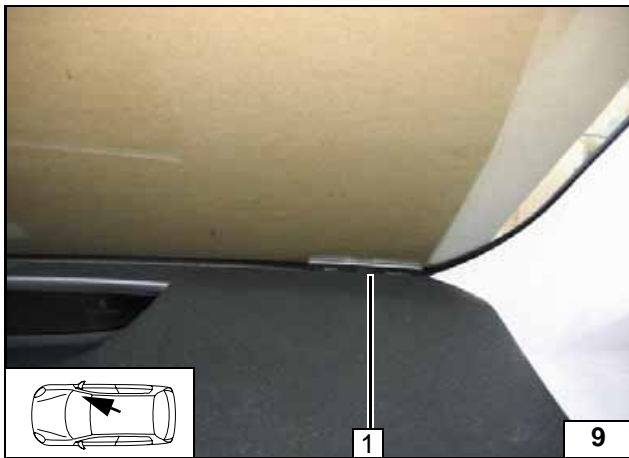

1 Antenna

Assembling the antenna

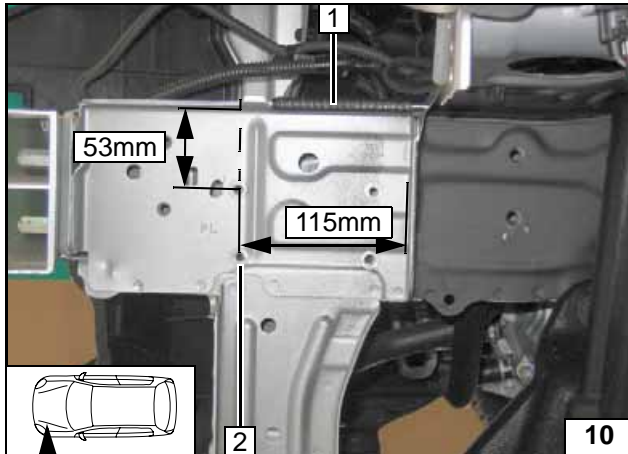
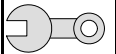

Preparing the Installation Location

- 1 Cut 100mm long edge protection to size, insert.
- 2 Ø 9.1mm bore hole, insert rivet nuts

Inserting rivet nuts

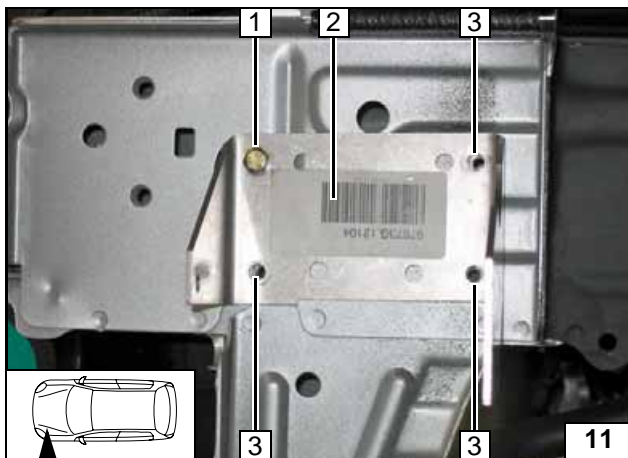

- 1 M6x25 bolt
- 2 Loosely fit the bracket
- 3 Transfer hole image, disassemble bracket, drill Ø 9.1mm bore hole; insert rivet nuts (3x each)

Copying the hole image

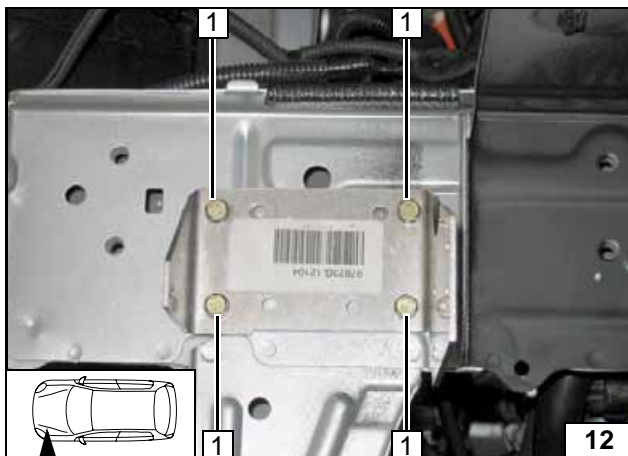

Insert one 5 mm spacer each bracket and frame side rail.

- 1 M6x25 bolt, 5 mm spacer (4x each).



Assembling the bracket

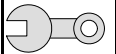

Preparing the Heater Unit

Ejot stay bolts, tightening torque 10 Nm.

- 1 E-jot stay bolts



Screw in E-jot stay bolts.

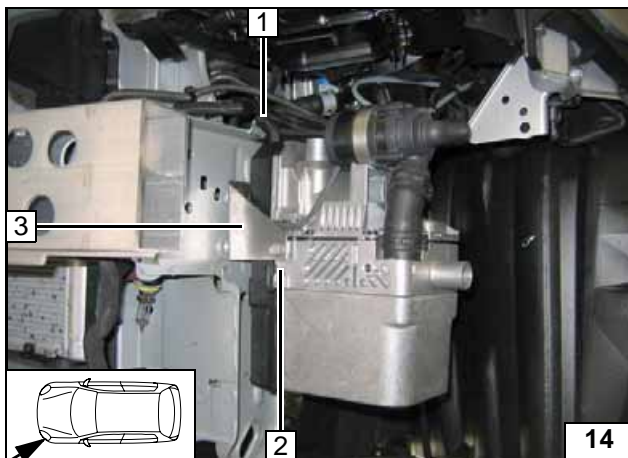

Installing the Heater Unit

Prior to assembly, put on the heater unit cable harness 1.

E-jot screw bolt tightening torque 10 Nm!

- 2 E-jot screw bolt
- 3 Bracket



Assembling the Heater Unit

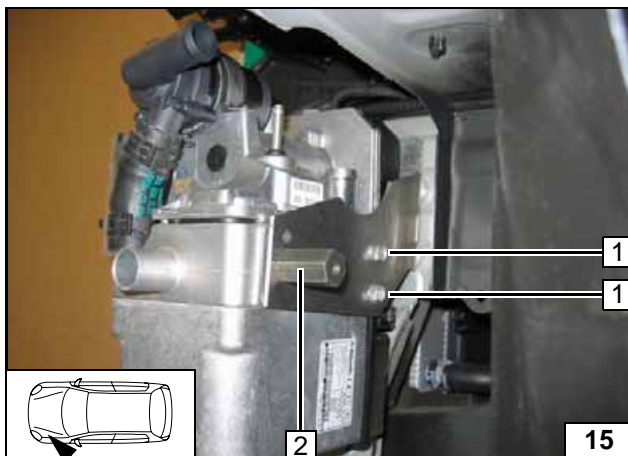

E-jot screw bolt tightening torque 10 Nm!

- 1 E-jot screw bolt (2x)
- 2 30 mm spacer nut



Assembling the bracket



Water Connection

WARNING!

Tighten all hose clamps to 2.0 + 0.5 Nm.

Any coolant running off should be collected using an appropriate container!

Install hoses so that they are kink-free! Unless specified otherwise, always fasten using cable clips!

Position hose clamps and spring band clamps so that no other hose can be damaged!

The connection should be "inline" based on the following diagram:

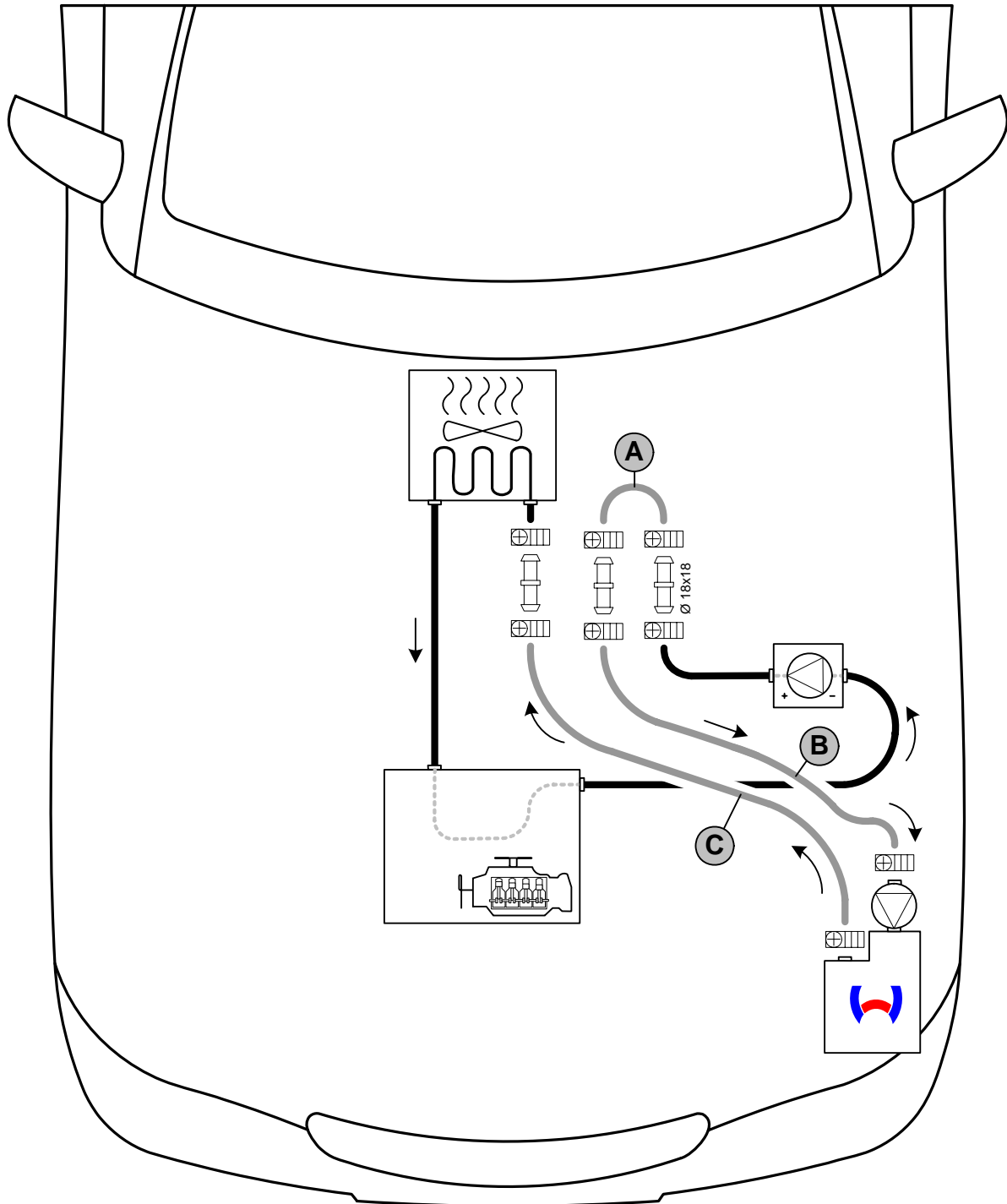

Water installation diagram

All undesignated hose clamps  = Ø 20-27 mm.

All undesignated connecting pipes  = Ø 18x20.



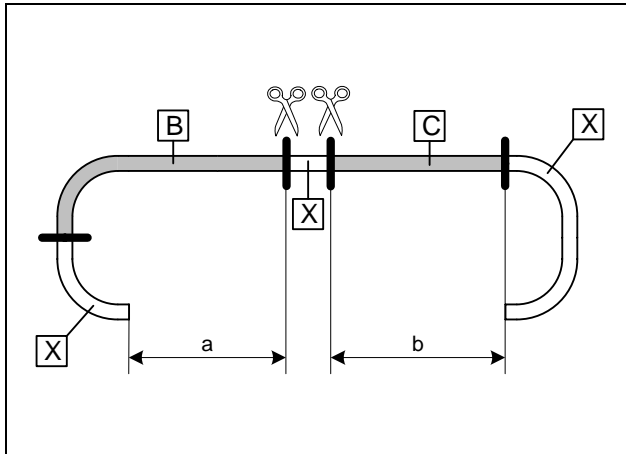

a = 960mm
b = 1,080mm

Dispose of section X

Cutting water hoses into sections

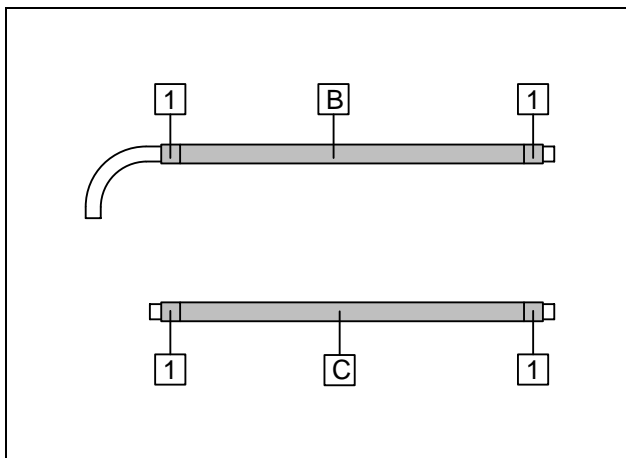

Slide the braided protective hoses onto hose B and hose C and cut into sections. Cut shrink-fit hose to size.



1 25 mm shrink-fit hose [4x]

Preparing the water hoses

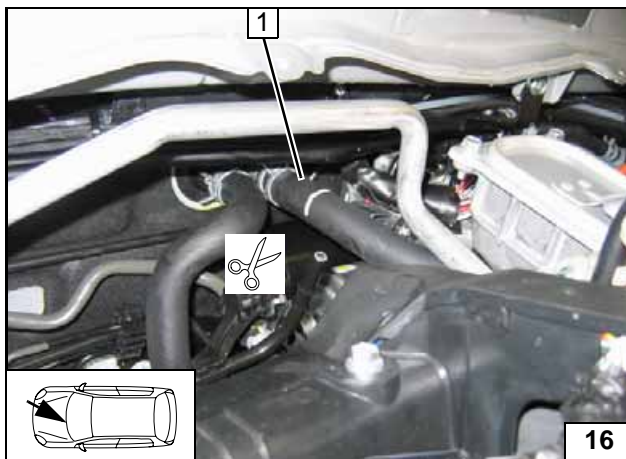

1 Heat exchanger inlet hose section

Splitting point

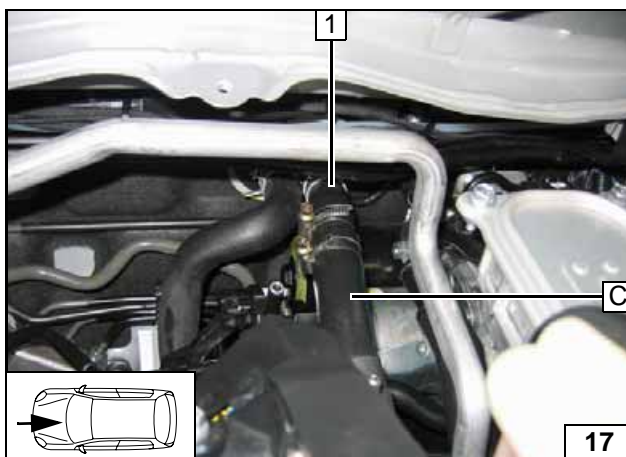

1 Heat exchanger inlet hose section

Assembling hose B

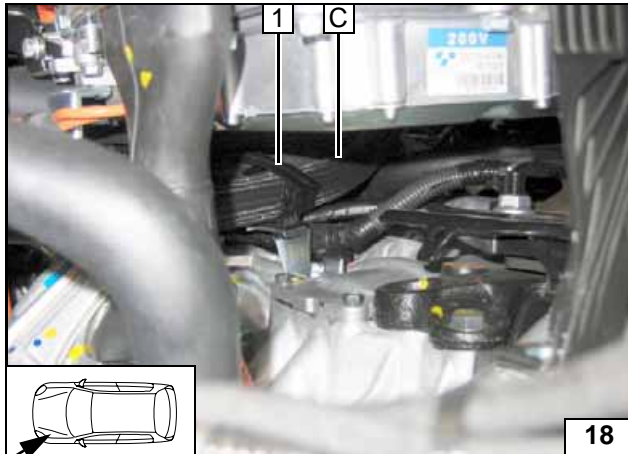

1 Original vehicle clamp

Running hose C

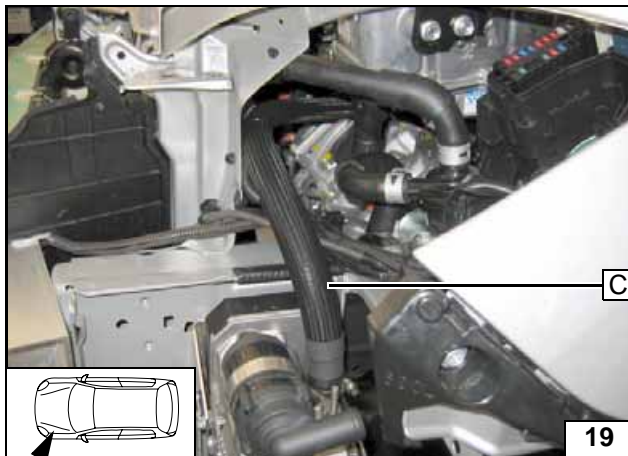

Connecting the heater unit outlet

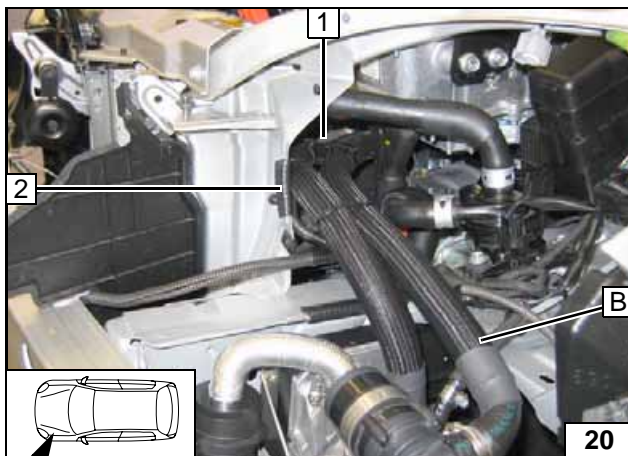

Run hose B along hose C.

- 1 Spacer bracket
- 2 Cut 70mm long edge protection to size, insert.



Connecting the heater unit inlet

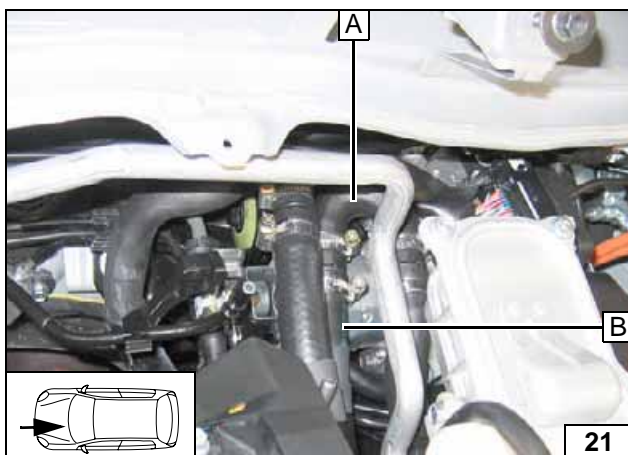

Connect hose A (enclosed 180° bend) with hose B.



Connecting engine outlet

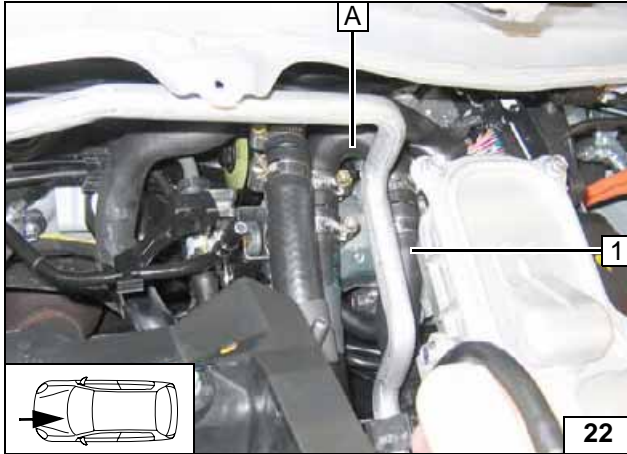

Before connecting, fill the water hoses with coolant.

- 1 Engine outlet hose section / electric water pump



Connecting engine outlet



Fuel Connection

CAUTION!

Open the vehicle's tank-cap lock, ventilate the tank and then re-close the tank lock.

Catch any fuel running off with an appropriate container.

Install fuel line and metering pump cable harness so that they are protected against stone impact. Unless specified otherwise, always fasten using cable clips! Fit the fuel line and cable harness with edge protectors around sharp edges.

WARNING!

The fuel line and cable harness to the metering pump should be installed on the original vehicle fuel lines based on the cable harness installation diagram.

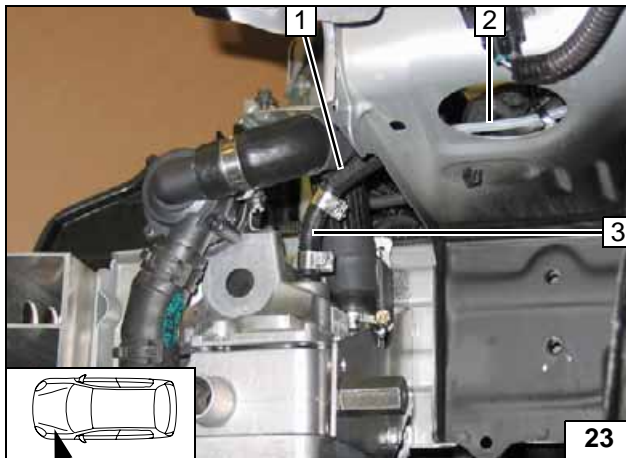

Slide a cloth hose section 1 on the fuel line 2 as an edge protector.

3 Hose section, Ø 10 mm hose clamps

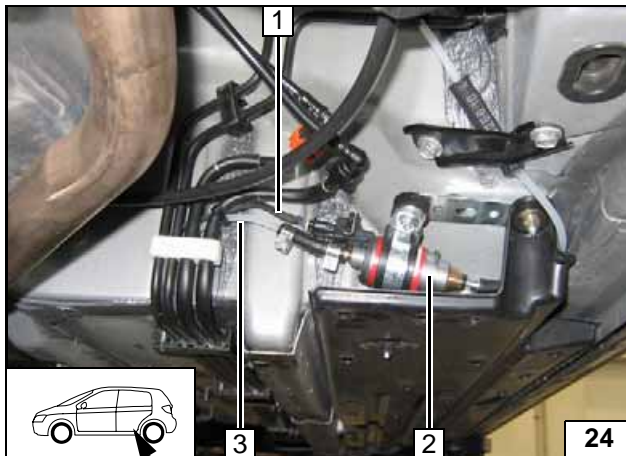

Note the installation position of the metering pump 2, see the "Installation Instructions". The installation location is to the right in front of the vehicle tank.

1 Metering pump cable harness
3 Fuel line from the heater unit

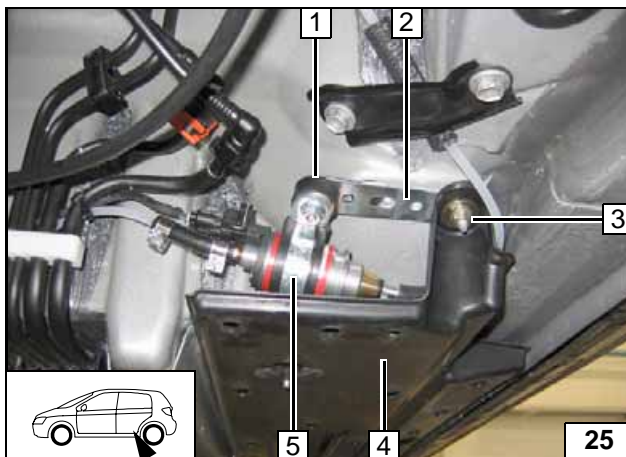

Re-assembling the underride protection 4. Position the fastening strap 2 according to the illustration, bend as necessary. Ensure sufficient distance from adjacent components.

1 Silent block, flanged nut [2x]
3 Original vehicle stay bolts, body washer, flanged nut
5 Rubberized tube clamp



Connection to heater



Metering pump installation location



Assembling the metering pump

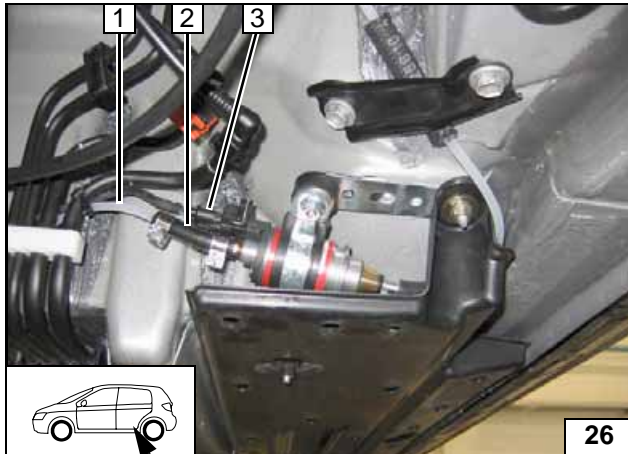

Fuel line from the heater unit 1 on the pressure side of the metering pump [side with connector].

- 2 Hose section, Ø 10 mm hose clamps [2x]
- 3 Metering pump cable harness, wire seals, flat connector, connector housing

Connection to metering pump

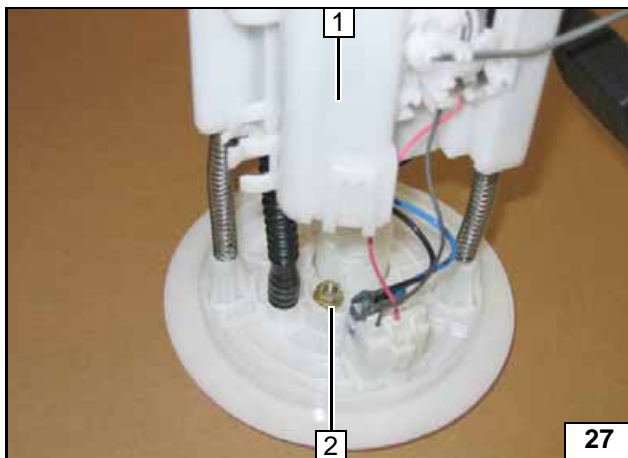

Remove the tank mounting 1 according to the manufacturer's instructions and take it apart.

- 2 Align the flanged nut to the left on the struts, copy the hole image, bore hole Ø 6mm

Fuel take-off

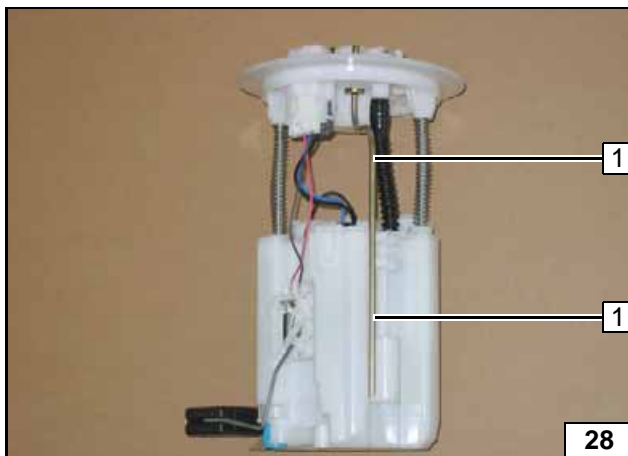

Shape, cut into sections, and insert the tank extracting device 1 according to the template, see the Installation Instructions.

Inserting tank extracting device

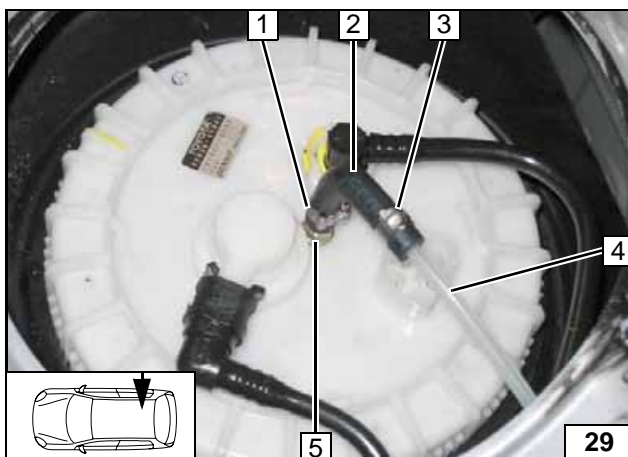

Install the tank mounting according to manufacturer's instructions. Shorten the moulded hose 2 by 10 mm for Ø 3.5 mm.

- 1 Universal clip Ø 9mm
- 2 Molded hose Ø 3.5 mm x 4.5 mm
- 3 Universal clip Ø 10 mm
- 4 Fuel line
- 5 Tank extracting device

Connecting and disconnecting the fuel pipe



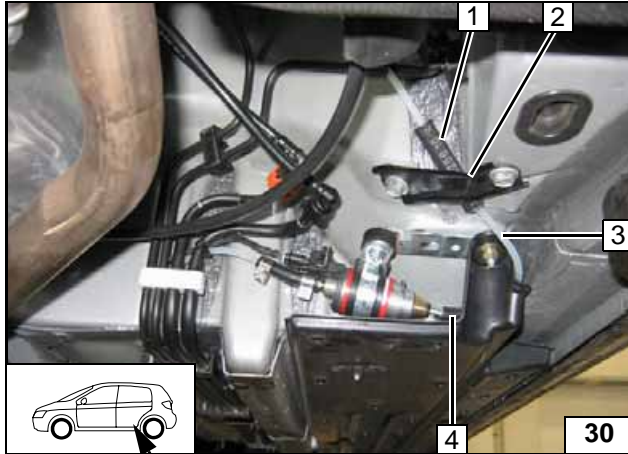

Slide the cloth hose section **1** on the fuel line **3** as an edge protector and connect to the intake side of the metering pump [side without connector].

Check the position of the components; adjust if necessary. Check that they have free clearance.

2 Cable clip

4 Hose section, Ø 10 mm hose clamps [2x]



Connection to metering pump

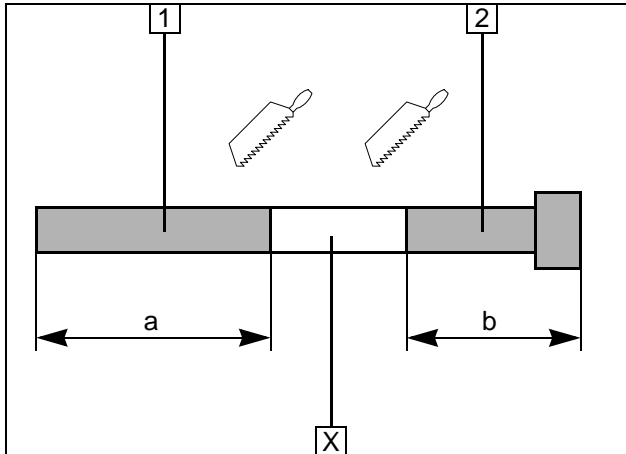
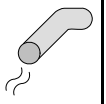

Exhaust System

- 1 Exhaust pipe
a = 200mm
- 2 Exhaust end section
b = 250mm

Dispose of section X

Preparing the exhaust pipe

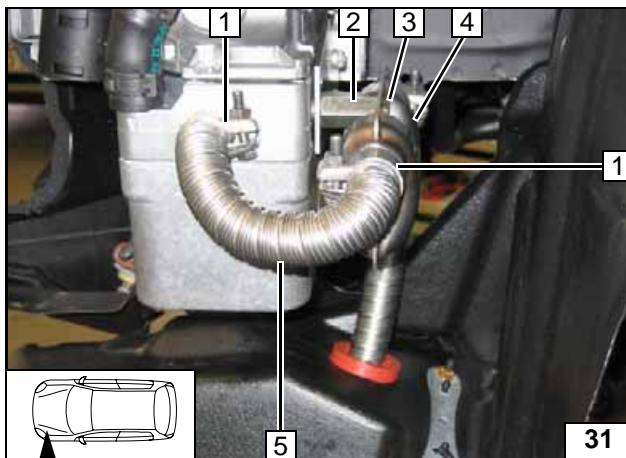

- 1 Hose clamp [2x]
- 2 30 mm spacer nut
- 3 M6x16 bolt on spacer nut
- 4 Silencer
- 5 Exhaust pipe

Assembling the silencer / exhaust line

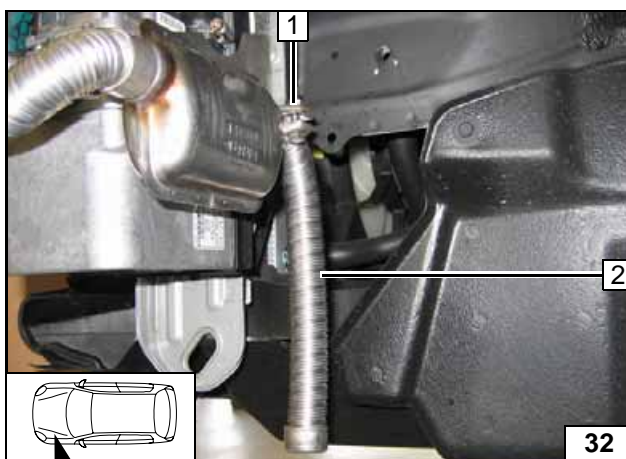

- 1 Hose clamp
- 2 Exhaust end section

Assembling the exhaust pipe.

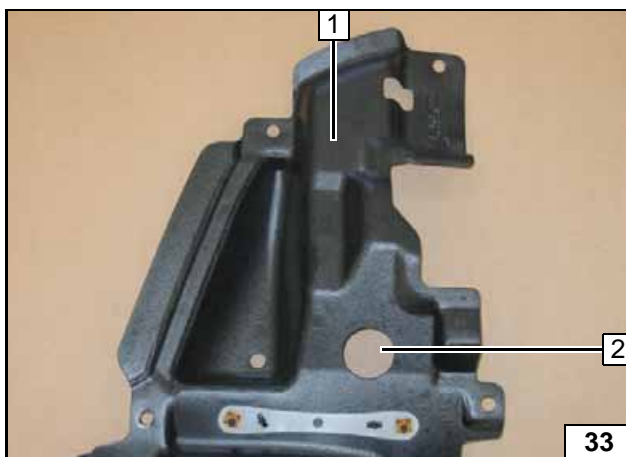

- 1 Left wheel house
- 2 Ø 42 mm bore hole

Bore hole wheel house

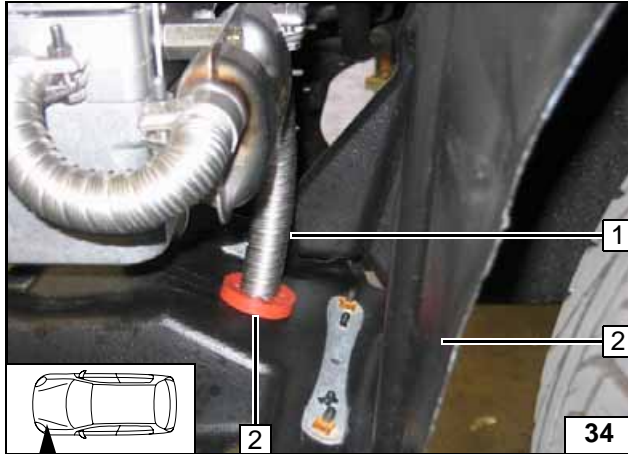
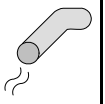

Reassemble the wheel house

- 1 Exhaust end section
- 2 Red (rt) rubber profile with groove



Inserting
rubber
profile

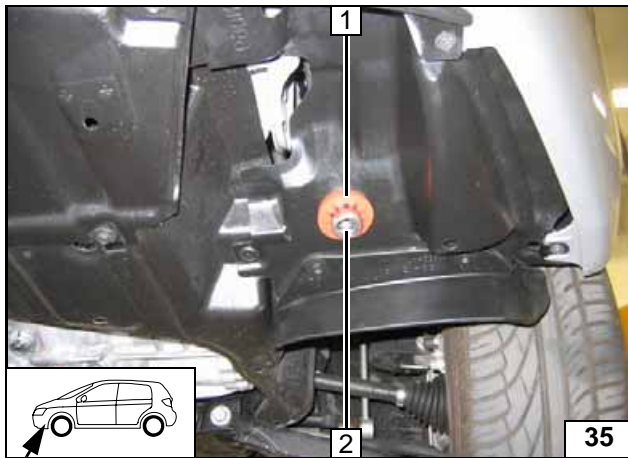

Align the exhaust end section 2 flush on the red rubber profile 1.
Ensure sufficient distance from adjacent components.



Inserting
rubber
profile

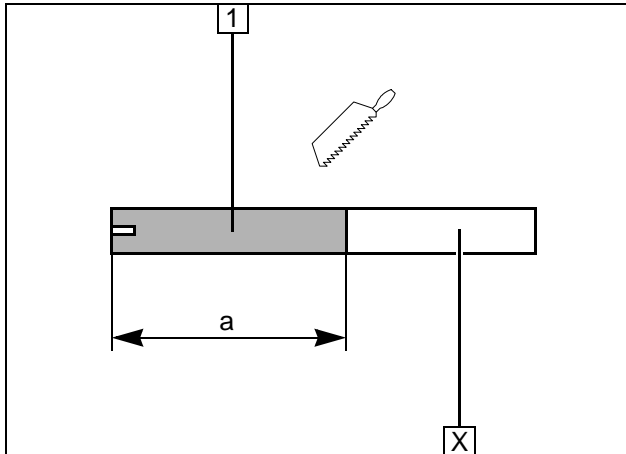

Combustion Air

- 1 Combustion air pipe
a = 160mm

Dispose of section X

Cutting the combustion air pipe into sections

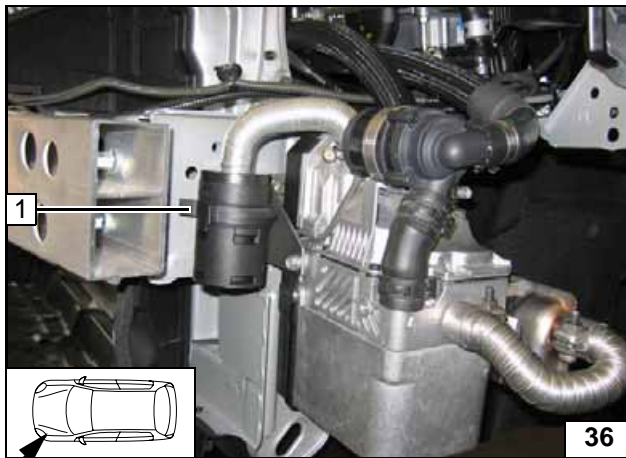

Insert retaining clip 1 in the existing bore hole in the frame side rail.



Assembling the retaining clip

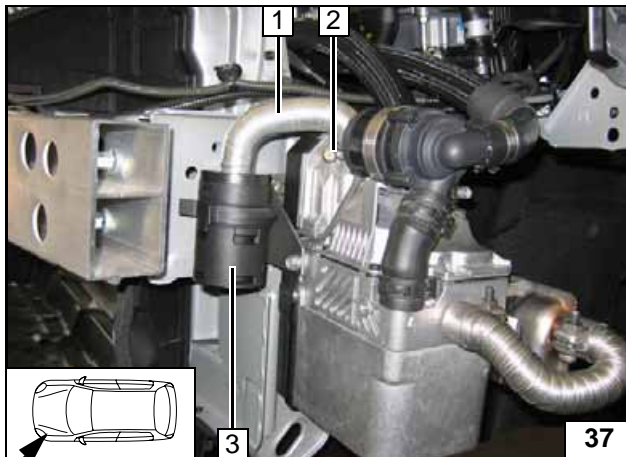

- 1 Combustion air intake pipe
- 2 Ø 27 mm hose clamp
- 3 Combustion air intake silencer



Assembling the silencer

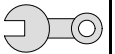

Final Work

WARNING!

Reassemble disassembled components in reverse order.

Check that all hose lines, clips, and all electrical connections are securely fastened.

Secure all loose cables using cable clips.

Only use manufacturer-approved coolant.

Spray heating unit components with anti-corrosion wax (Tectyl 100K, Order No. 111329).

- Connect battery
- Fill and bleed the coolant circuit according to the vehicle manufacturer's specifications.
- Set the time switch.
- Make settings according to "Operating instructions for the end customer".
- Check that the auxiliary heating operates properly, see operating instructions / installation instructions.
- Attach the "Switch off auxiliary heating before re-fuelling" sticker onto the left side of the B-pillar.

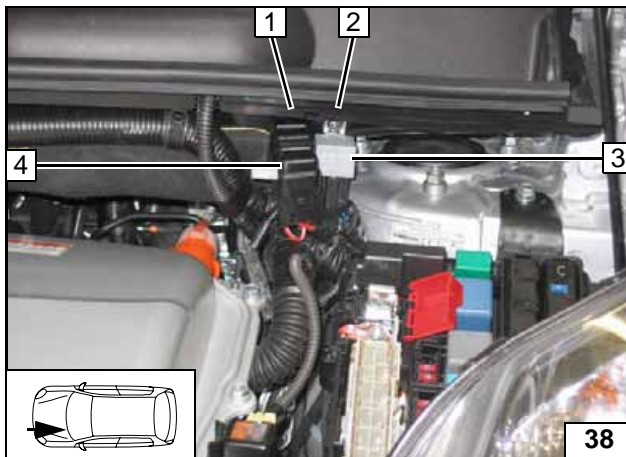

Installation location on the cooling water reservoir as shown in the figure.

- 1 Ø 4mm bore hole, 5.5x13 self-tapping screw; fuse holder retaining plate.
- 2 Ø 4mm bore hole, 5.5x13 self-tapping screw
- 3 K3 relay
- 4 Fitted fuse holder



**Assembling
the
electronics**

Webasto
Feel the drive

Webasto AG
PO Box 80 - 82132 Stockdorf
Hotline 01805 / 932278 - Hotfax 0395 / 5592-353
<http://www.webasto.de>

Operating instructions for the end customer



Please remove page and add to the vehicle operating instructions.

For short distance trips, it is not recommended that the rear window heating be used.

Rule of thumb for operating the auxiliary heating: driving time = heating time.

Before parking the vehicle, make the following settings:

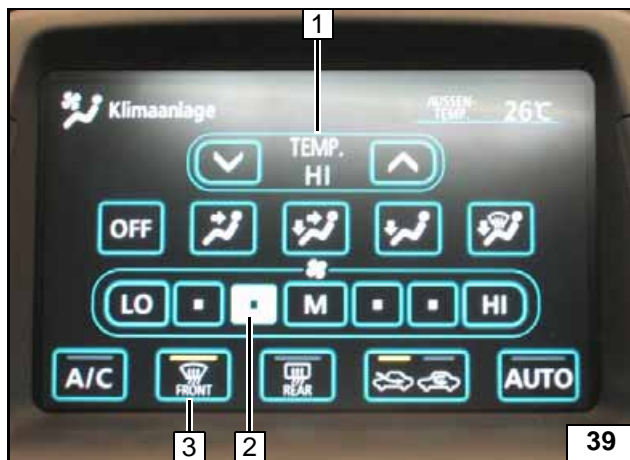

- 1 Temperature to "HI."
- 2 Blower set to level "2"
- 3 Air outlet to windscreen

Air conditioning settings

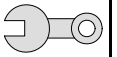

Tank Extracting Device Template

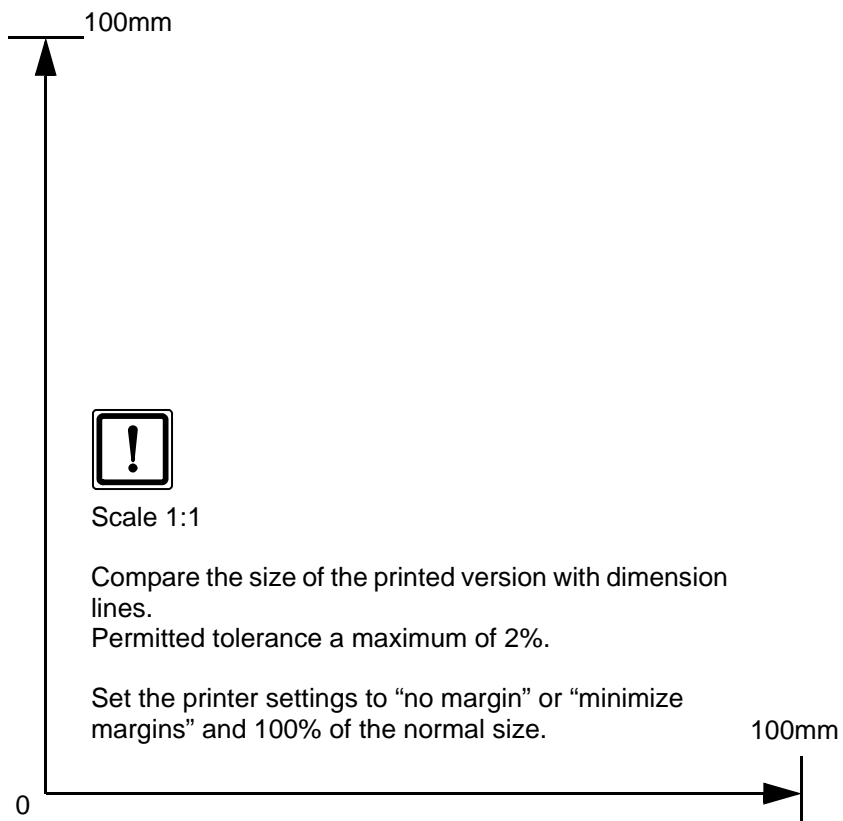
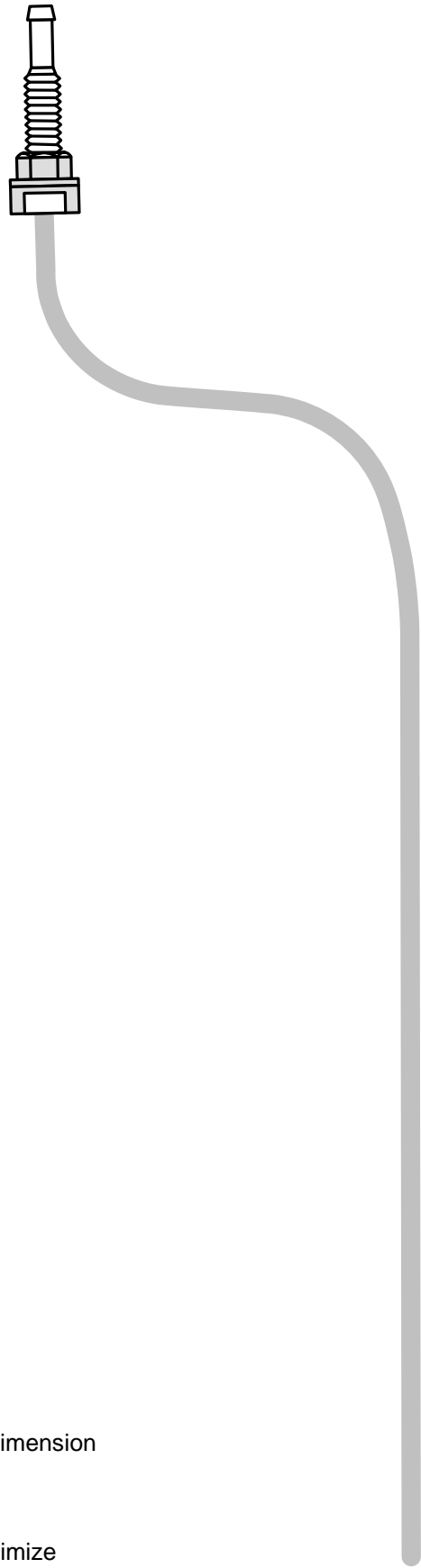

Scale 1:1

Compare the size of the printed version with dimension lines.
Permitted tolerance a maximum of 2%.

Set the printer settings to "no margin" or "minimize margins" and 100% of the normal size.