

Water Heater Unit



Thermo Top E Additional Heater

00 0003

Thermo Top C Additional Heater

00 0002

Thermo Top P Additional Heater

00 0104

Installation Instructions

VW Tiguan

Gasoline and Diesel
from Model Year 2008
Left-hand drive vehicle
Climatronic



WARNING!

Hazard warning:

Incorrect installation or repair of Webasto heating systems may cause a fire or result in the emission of carbon monoxide, which can be fatal. Serious or fatal injuries can be caused as a result.

Specialist company training, technical documentation, specialized tools and equipment are required to install and repair Webasto heating and cooling systems.

NEVER attempt to install or repair Webasto heating or cooling systems if you have not successfully completed the company training and thereby acquired the required technical skills, or if you do not have access to the required technical documentation, tools and equipment needed to carry out correct installation and repairs.

ALWAYS follow all Webasto installation and repair instructions and observe all warnings.

Webasto does not accept any liability for defects and damage that are attributable to installation by untrained staff.

Table of Contents

| | | | |
|-----------------------------------|----|-----------------------------------------|----|
| Validity | 2 | Preparing bracket | 12 |
| Heater Unit/Installation Kit | 3 | Premounting heater unit | 12 |
| Foreword | 3 | Installing heater unit | 14 |
| General Instructions | 3 | Coolant on 1.4 liter and 2.0 liter TSI | 16 |
| Special Tools | 3 | Coolant on 2.0 liter TDI | 21 |
| Explanatory Notes on Document | 4 | Fuel Connection | 25 |
| Preliminary Work | 5 | Exhaust gas | 29 |
| Heater unit installation location | 5 | Final Work | 30 |
| Preparing electrical system | 6 | Operating Instructions for End Customer | 31 |
| Electrical system | 7 | | |
| Fuse holder and relay K3 | 8 | | |
| Fan controller | 9 | | |
| Digital timer | 11 | | |
| Remote option (Telestart) | 11 | | |

Validity

| Manufacturer | Model | Type | EG-BE No./ABE |
|--------------|--------|------|----------------------|
| VW | Tiguan | 5N | e1 * 2001/116 * 0450 |

| Engine type | Engine model | Output in kW | Displacement in cm ³ |
|-------------|--------------|--------------|---------------------------------|
| BWK | Gasoline | 110 | 1390 |
| CAWA | Gasoline | 125 | 1984 |
| CAWB | Gasoline | 147 | 1984 |
| CBAB | Diesel | 103 | 1986 |
| CAHB | Diesel | 125 | 1986 |

Vehicle and engine types, equipment variants and national specifications not listed in these installation instructions have not been tested. However, installation according to these installation instructions may be possible.

The installation location of a digital timer and summer/winter switch should be confirmed with the end customer before installation.

VW Tiguan

Heater Unit/Installation Kit

| Quantity | Description | Order No.: |
|----------|----------------------------------------------------|----------------|
| 1 | Retail accessories with desired heater control | See price list |
| 1 | Installation kit for VW Tiguan Gasoline and Diesel | 1313473B |

Other required parts

| Quantity | Description | VW Order No.: |
|----------|--------------|---------------|
| 1 | Plate washer | 191 411 331 |

Also required with Climatronic

| Quantity | Description | Order No.: |
|----------|-------------------------------|------------|
| 1 | Kit for Climatronic VW Tiguan | 1313474A |

Heater unit recommended for the respective vehicle class:

| Vehicle | Heater Unit |
|-------------------------------|--------------|
| Compact car | Thermo Top E |
| Mid-size car, station wagon | Thermo Top C |
| Full-size car, van, offroader | Thermo Top P |

The selection of the heater unit is based on the passenger compartment size of the vehicle and the level of comfort required by the customer!



Foreword

These installation instructions apply to VW Tiguan Gasoline and Diesel vehicles - for validity, see page 2 - from model year 2008 and later, assuming technical modifications to the vehicle do not affect installation, any liability claims excluded. Depending on the vehicle version and equipment, modifications may be necessary during installation with respect to these installation instructions.

However, the stipulations in the "installation instructions" and "operating and maintenance instructions" for the *Thermo Top C/P/E* must always be observed.

The corresponding rules of technology and any information from the vehicle manufacturer should be observed during the installation work.

General Instructions

Installation should be carried out according to the general, standard rules of technology. Unless specified otherwise, fasten hoses, lines and wiring harnesses to original vehicle lines and wiring harnesses using cable ties.

Sharp edges must be provided with rub protection (cut-open fuel hose)!

Spray unfinished body areas, e.g. drilled holes, with anti-corrosion wax (Tectyl 100K, Order No. 111329).

Special Tools

- Torque wrench for 2.0 - 10 Nm
- Hose clamping pliers

Explanatory Notes on Document

To provide you with a quick overview of the individual working steps, you will find an identification mark on the outside top right corner of the page in question.

Mechanical system

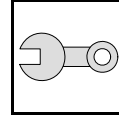

Electrical system

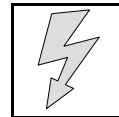

Coolant

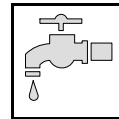

Fuel

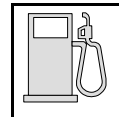

Exhaust gas

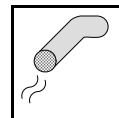

Combustion air

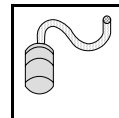

Special features are highlighted using the following symbols:



Specific risk of injury or fatal accidents.



Specific risk of damage to components.



Specific risk of fire or explosion.



Reference to general installation instructions of Webasto components or to the manufacturer's vehicle-specific documents.



Reference to a special technical feature.



The arrow in the vehicle icon indicates the position on the vehicle and the viewing angle.

All dimensions are in mm!

Tightening torque of hose clamps = 2.0 + 0.5 Nm!

Tightening torque of Eجت screws, Eجت studs = 10 Nm!

Preliminary Work

WARNING!

- Open the fuel tank cap and vent the fuel tank.
- Close the tank cap again.
- Depressurize the cooling system.
- Copy the factory number from the original type label to the duplicate type label.
- Remove years that do not apply from the duplicate label.
- Attach the duplicate label (type label) in the appropriate place.
- Disconnect the battery "earth" or "ground" connection.
- Remove the battery
- Remove the battery carrier
- Remove the engine cover
- Remove the air filter (only on 2.0 TSI).
- Remove the right-hand charge-air tube.
- Remove the charge-air tube completely (only on 2.0 TSI).
- Remove the front right wheel well trim and detach on the left.
- Remove the bumper
- Remove the underride protection
- Remove the right-hand underbody trim
- Remove right rear single seat
- Open the right-hand fuel sender service lid
- Remove the footwell trim on the driver's side
- Remove the lower instrument panel trim on the driver's side
- Remove the footwell trim on the front passenger side

Remove page 31 "Operating Instructions for End Customer" and add to the vehicle operating instructions.

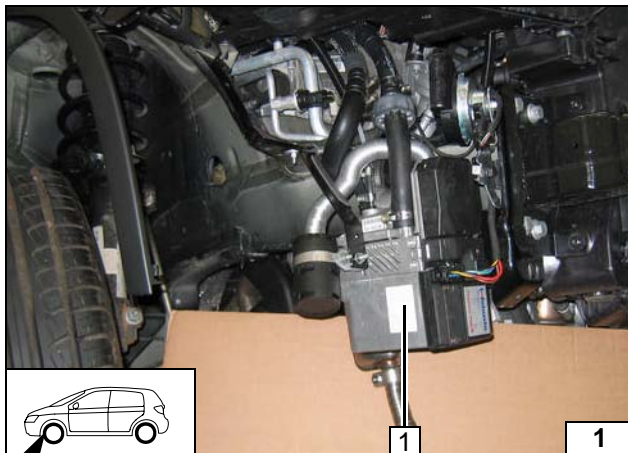

Heater unit installation location

1 Heater unit

Installation location



Preparing electrical system

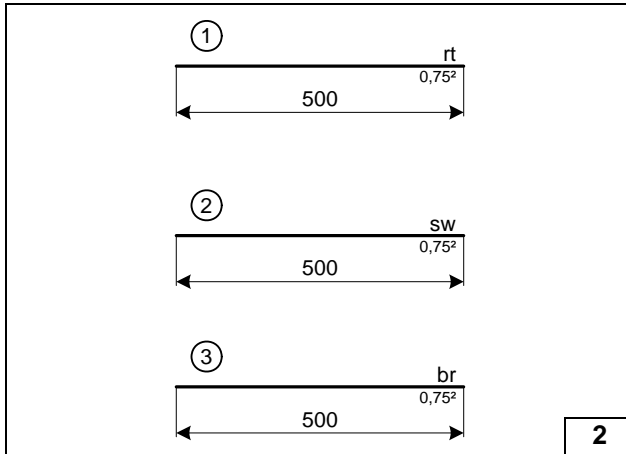

Lines for IPCU

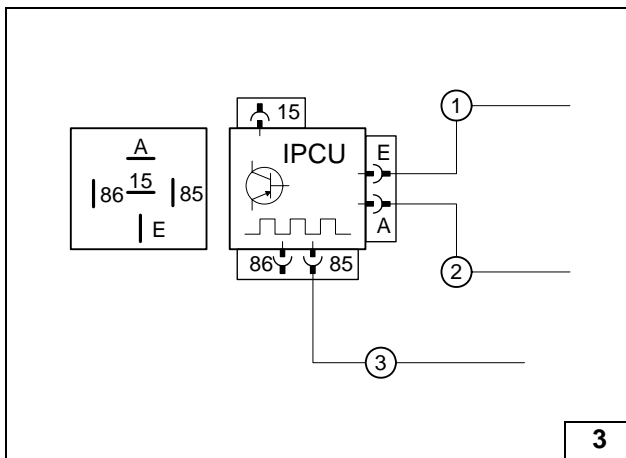

Install lines according to wiring diagram.



Preparing IPCU



Electrical system

Wiring harness pass through

1 Original vehicle wiring harness pass through

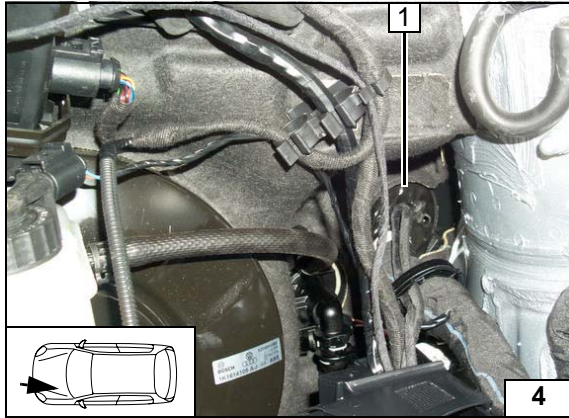

Wiring harness pass through

1 Original vehicle wiring harness pass through

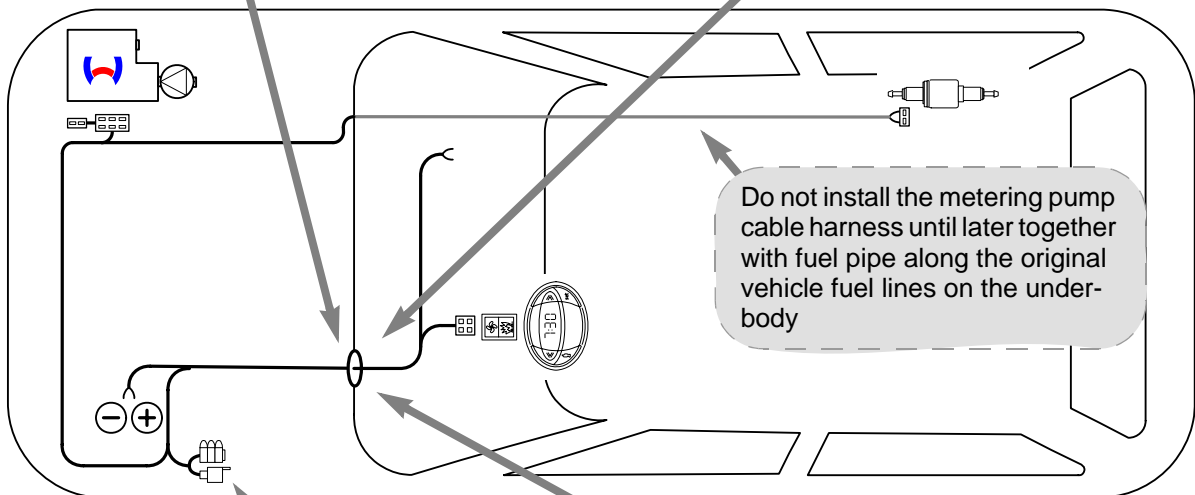
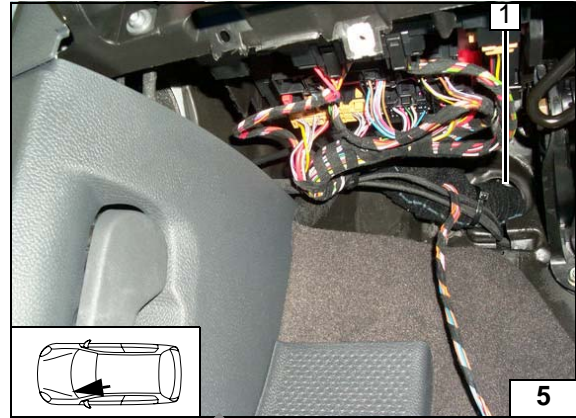

Wiring harness installation diagram

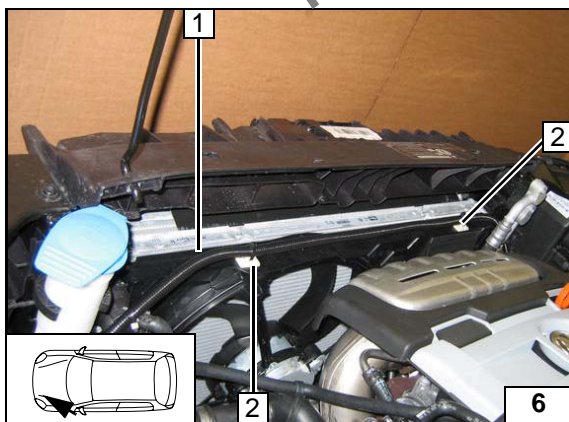

Routing wiring harness

1 Wiring harness of heater unit and wiring harness of metering pump in corrugated tube
2 Adhesive base [2x]

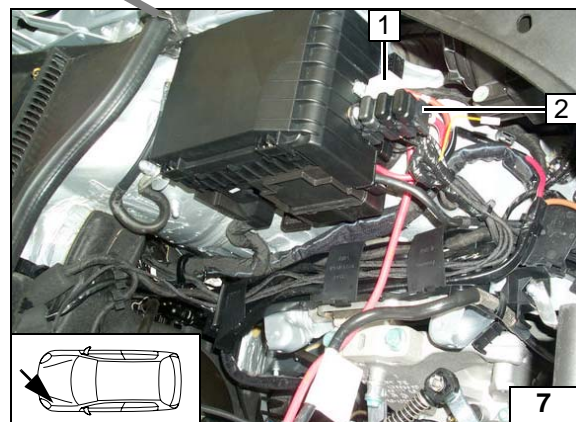

Fuse holder, K3 relay

Description of installation for K3 relay 1 and fuse carrier 2 on Page 7

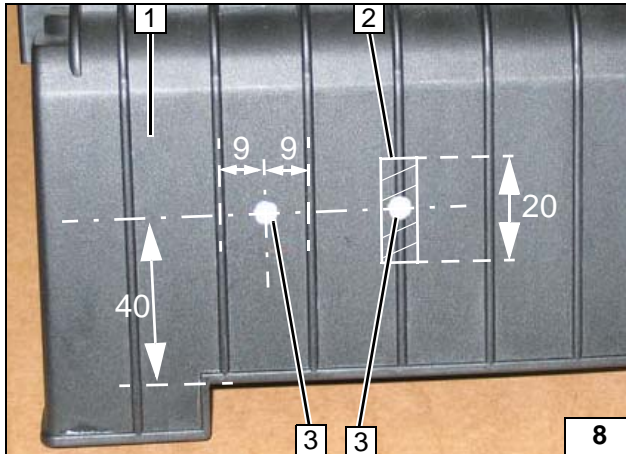
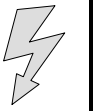

Fuse holder and relay K3

Countersink holes **3** from behind for M5 countersunk head screws.

- 1** Cover of fuse/relay carrier in engine compartment
- 2** Cut away bar in shaded area
- 3** 5.0 mm dia. hole [2x]



Holes in cover

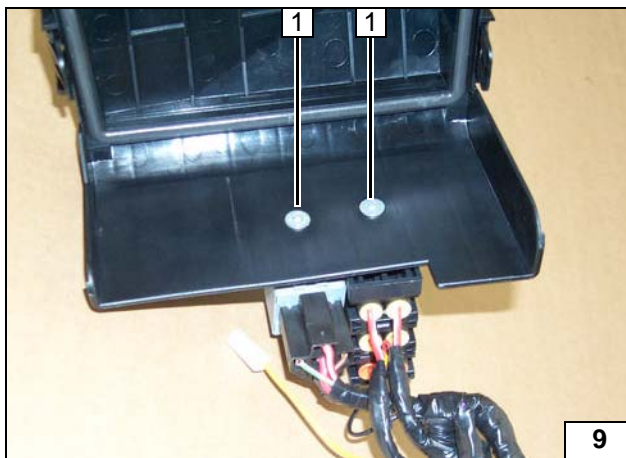

- 1** M5x12 countersunk head screw [2x]

Installing fuse holder and K3 relay

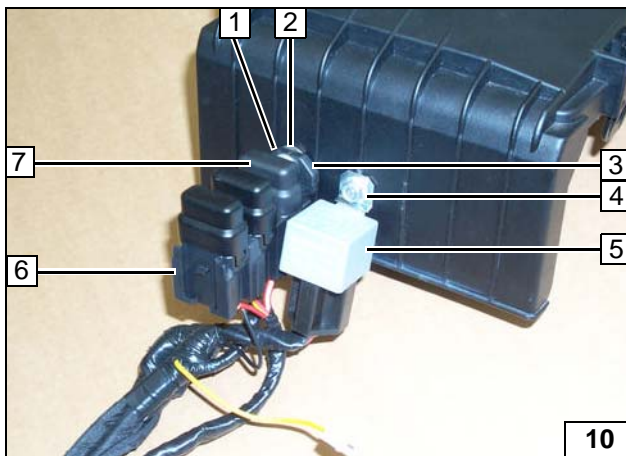

On vehicles with Climatronic, replace 25 A fuse F3 **7** with 3 A fuse provided.

- 1** M5 flanged nut
- 2** Large diameter washer (between cover and retaining plate)
- 3** Retaining plate
- 4** M5 flanged nut
- 5** Relay K3
- 6** Fuse holder



Installing fuse holder and K3 relay

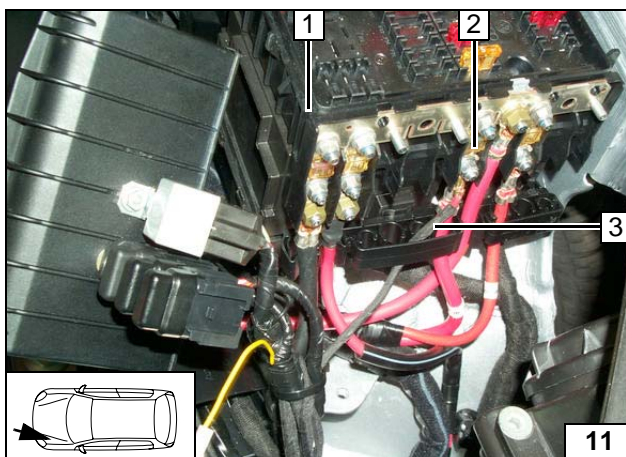

Route brown (br) ground wire to original vehicle ground support point below headlight and connect.

- 1** Fuse/relay carrier
- 2** Original main vehicle fuse
- 3** Red (rt) positive wire



Connecting positive and ground wire



Fan controller

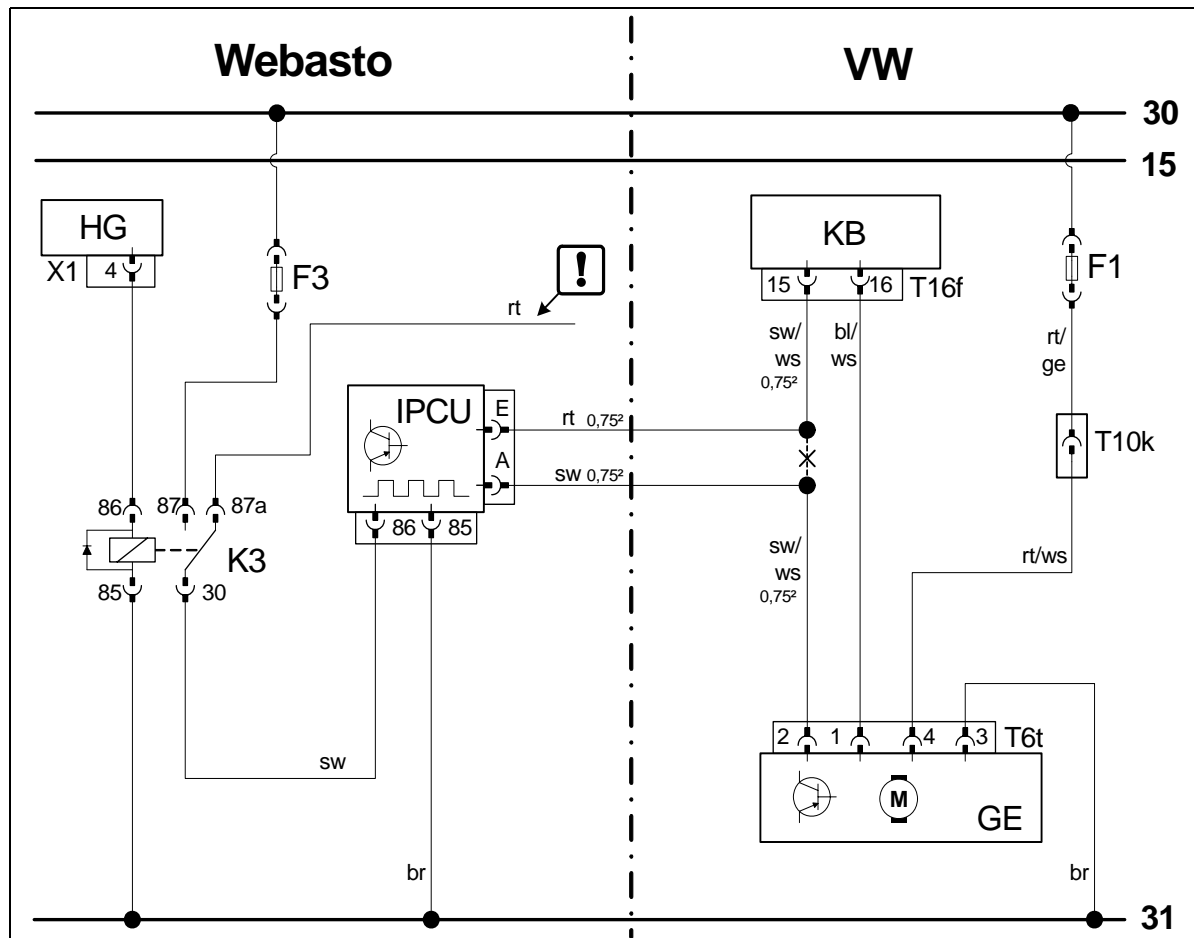

Wiring diagram

| Webasto components | | Vehicle components | | Colors and symbols | |
|-------------------------------|--------------------------------|--------------------|--------------------------------------------|--------------------|---------------------------------|
| HG | Heater unit TT-C/E | F1 | Fuse SC22 or SC56 with 40 A | rt | red |
| X1 | 6-pin heater unit connector | | | ws | white |
| K3 | Fan relay | KB | Climatronic control unit - J255 | sw | black |
| F3 | Fuse (25 A replaced with 3 A!) | T10k | Plug connections | br | brown |
| IPCU | Pulse width modulator | ge | Fan control unit - J126 and fan motor - V2 | gn | green |
| IPCU adjustment values | | | | ge | yellow |
| Voltage: 8 V | | | | bl | blue |
| Frequency: 400 Hz | | | | ! | Insulate wire ends and tie back |
| Duty cycle: 30 % | | | | | |
| Function: High-side | | | | X | Cutting point |

Legend

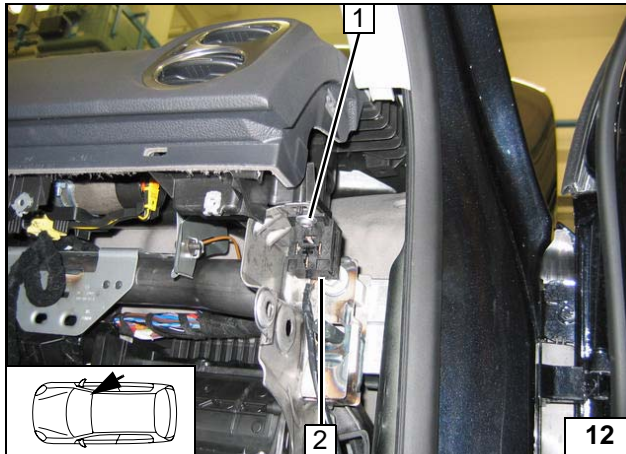

- 1 Original vehicle bolt
- 2 IPCU socket

Installing IPCU

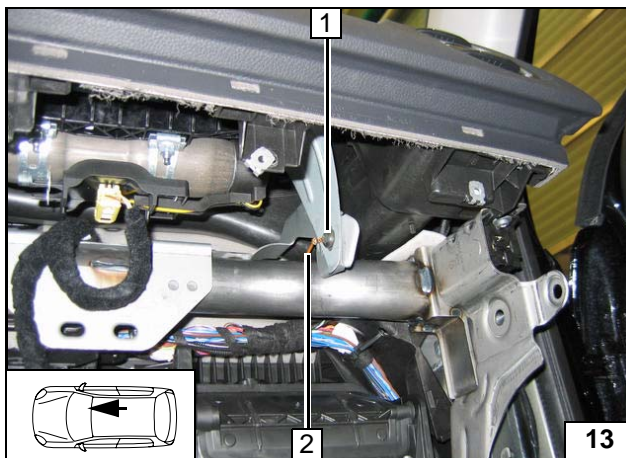

- 1 Original vehicle bolt
- 2 Brown (br) wire of IPCU/85

**Conne-
ction to
ground of
IPCU**

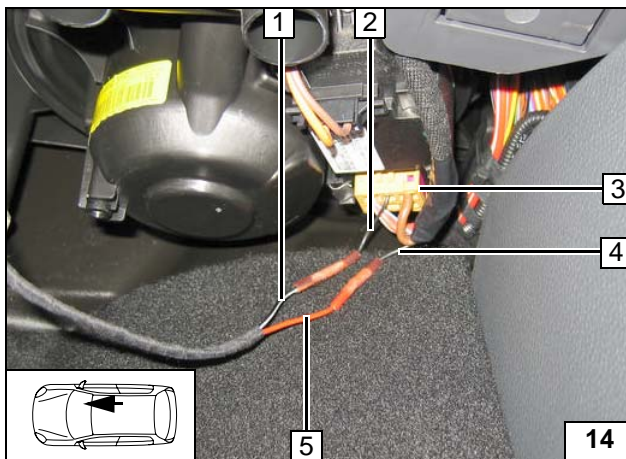

- 1 Black (sw) wire of IPCU/A
- 2 Black/white (sw/ws) wire of connector T6t/2
- 3 Connector T6t
- 4 Black/white (sw/ws) wire of Climatronic connector T6t/15
- 5 Red (rt) wire of IPCU/E

**Connect-
ing wires**

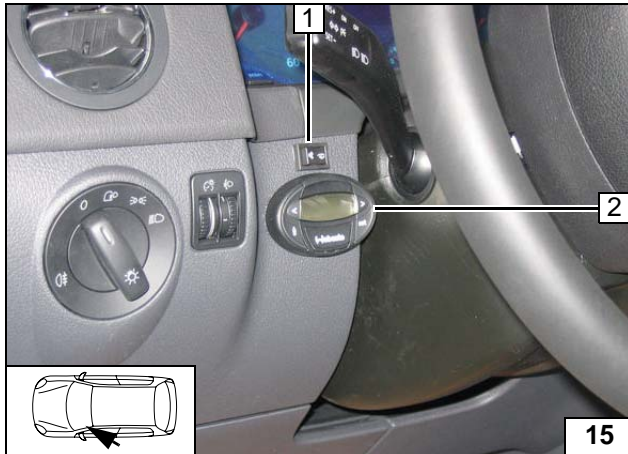

Digital timer

- 1 12 mm dia. hole, summer/winter switch
- 2 Digital timer



Installing digital timer

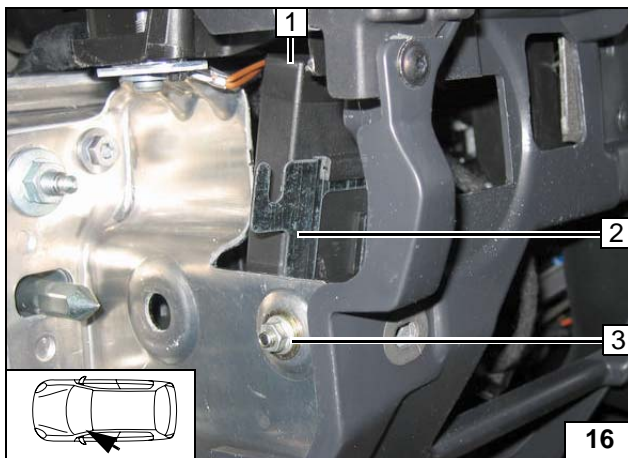

Remote option (Telestart)

Bend down lower tab of bracket by 90° and drill out hole to 6.5 mm dia. as shown.

- 1 Receiver
- 2 Bracket
- 3 M6 bolt, large diameter washer (between bracket instrument carrier), large diameter washer (from outside), flanged nut



Installing receiver

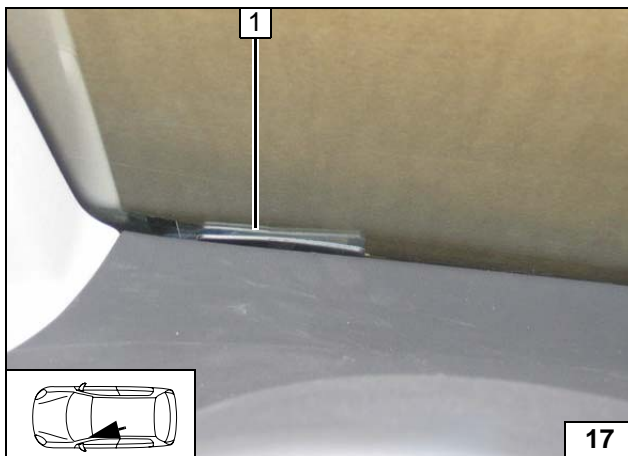

- 1 Antenna



Installing antenna

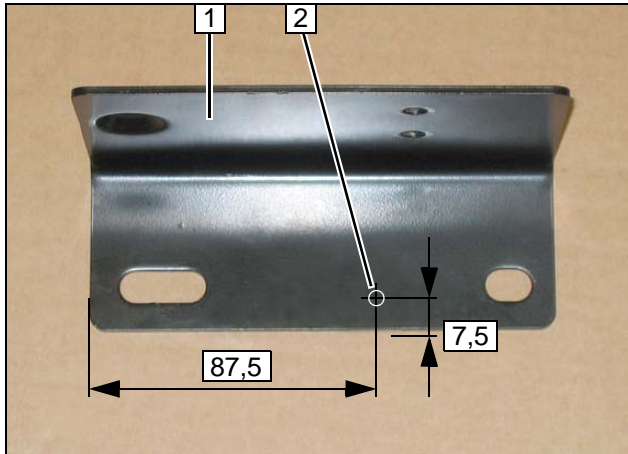
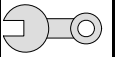

Preparing bracket

16 mm dia. hole in bracket 1 at position 2.



Hole in bracket

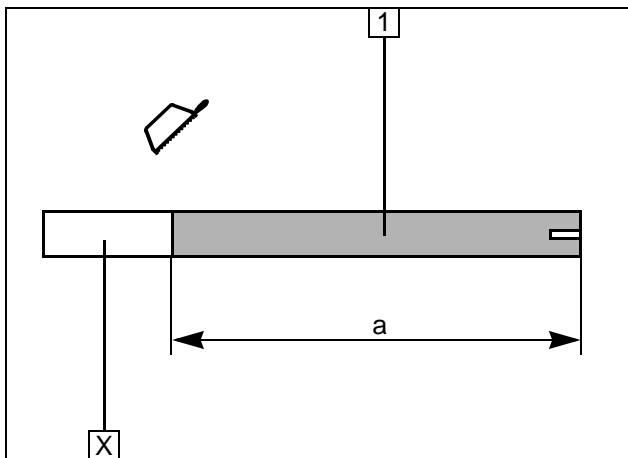

Premounting heater unit

1 Combustion air pipe
a = 270

Discard section X

Cutting combustion air pipe to length

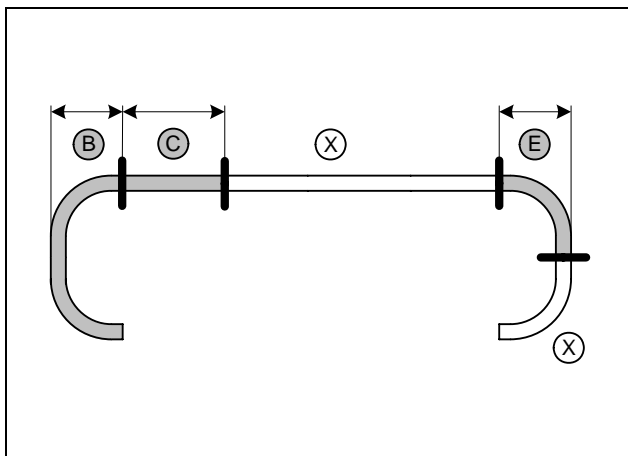

1.4 and 2.0 TSI

b = 70
c = 160
e = 70

Discard section X

Cutting 20 mm dia. coolant hose to length

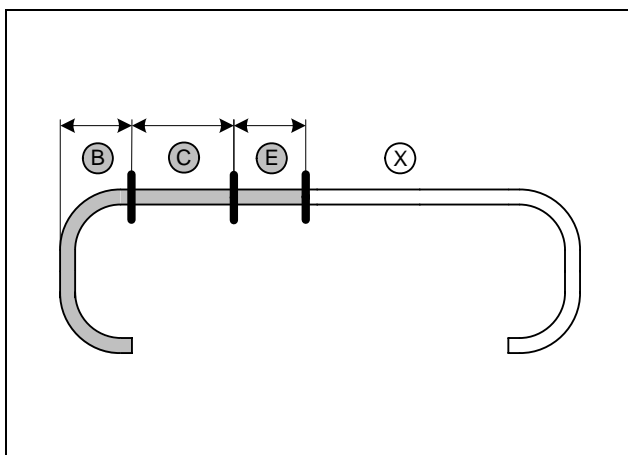

2.0 TDI

b = 70
c = 160
e = 70

Discard section X



Cutting 20 mm dia. coolant hose to length

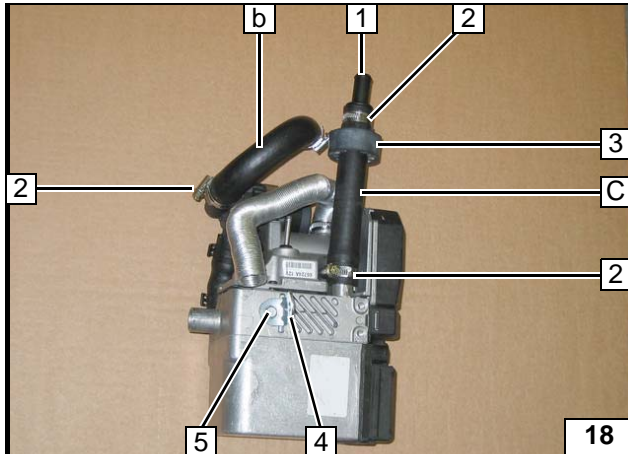

All vehicles

- 1 15x20 connecting pipe
- 2 Hose clamp [3x]
- 3 Black (sw) rubber isolator
- 4 Angle bracket
- 5 Ejot screw

Premounting heater unit

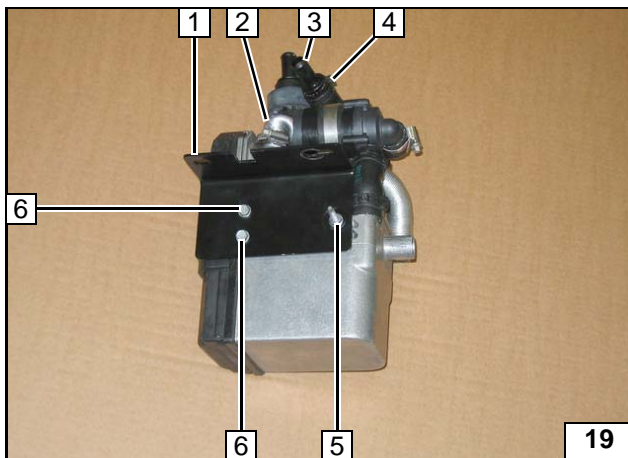

- 1 Bracket
- 2 Combustion air pipe, 10 mm dia. hose clamp
- 3 15x20 connecting pipe
- 4 10 mm dia. hose clamp
- 5 Ejot stud, flanged nut
- 6 Ejot screw [2x]

Premounting heater unit

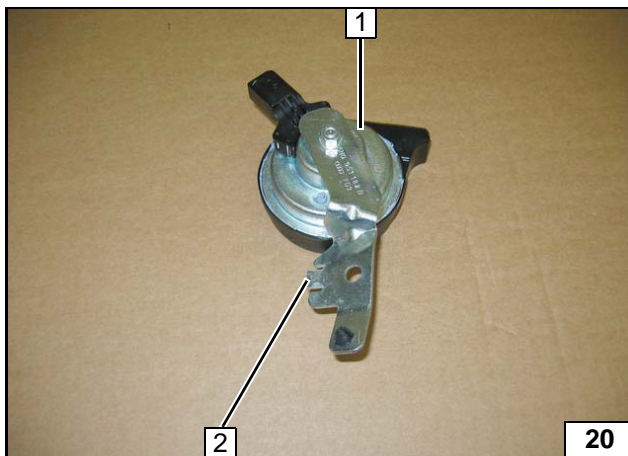

Preparing installation location

Remove horn 1 and bend lug 2 by 180°



Preparing installation location

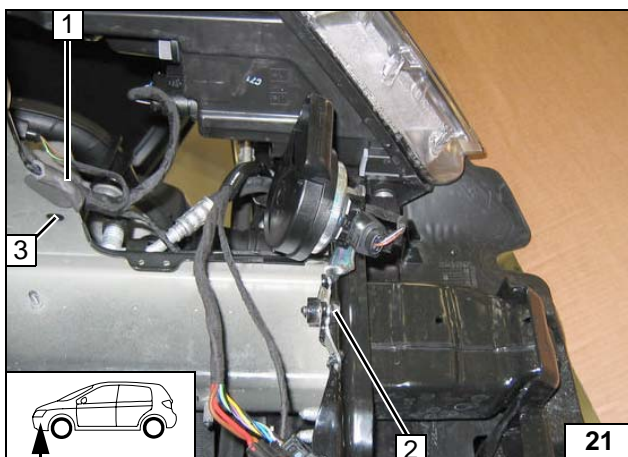

- 1 Glue on sponge rubber as rub protection
- 2 Original vehicle bolt
- 3 Remove clip from hole

Installing horn

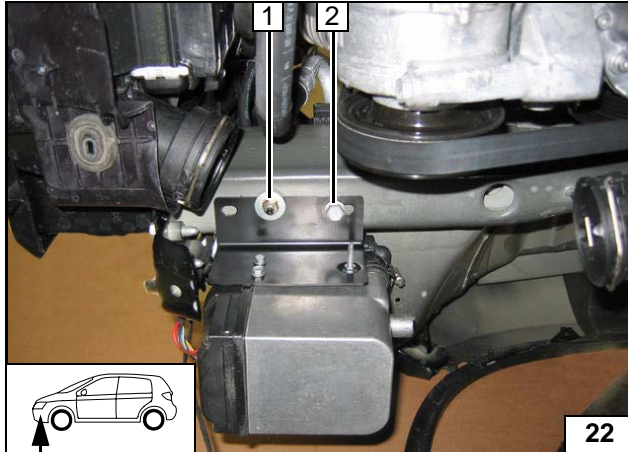
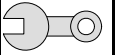

Installing heater unit

Connect wiring harness of heater unit prior to installation. Insert plate washer (VW Order No. 191 411 331) at position 1.

- 1 Original vehicle stud bolt, plate washer, M8 nut
- 2 M10x30 bolt with locking pawl in existing thread



Installing heater unit

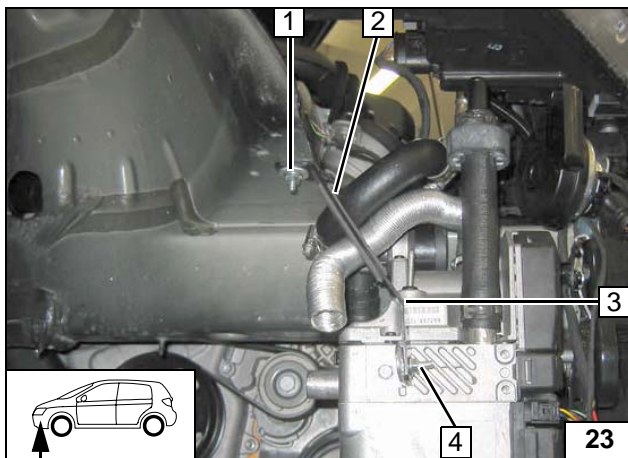

Before installation, glue sponge rubber 2 onto strut 3.

- 1 M6x20 bolt, large diameter washer [2x], M6 flanged nut
- 4 M6x20 bolt, M6 flanged nut



Installing strut

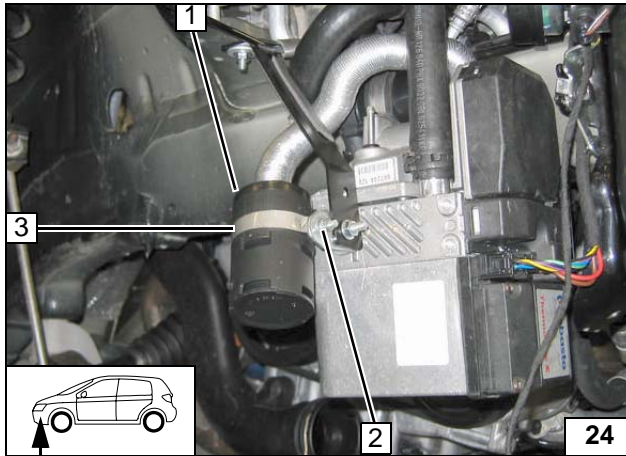
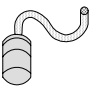

- 1 Intake muffler
- 2 M5x16 bolt, large diameter washer, M5 flanged nut
- 3 51 mm dia. p-clamp

**Installing
intake muf-
fler**

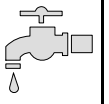

Coolant on 1.4 liter and 2.0 liter TSI



WARNING!

Any coolant running off should be collected using an appropriate container! Route coolant hoses kink-free! Unless specified otherwise, always fasten using cable ties. Position clamps so that no other hose can be damaged! When installing the coolant hose, the heater unit must be filled with coolant. The connection should be "inline" based on the following diagram:

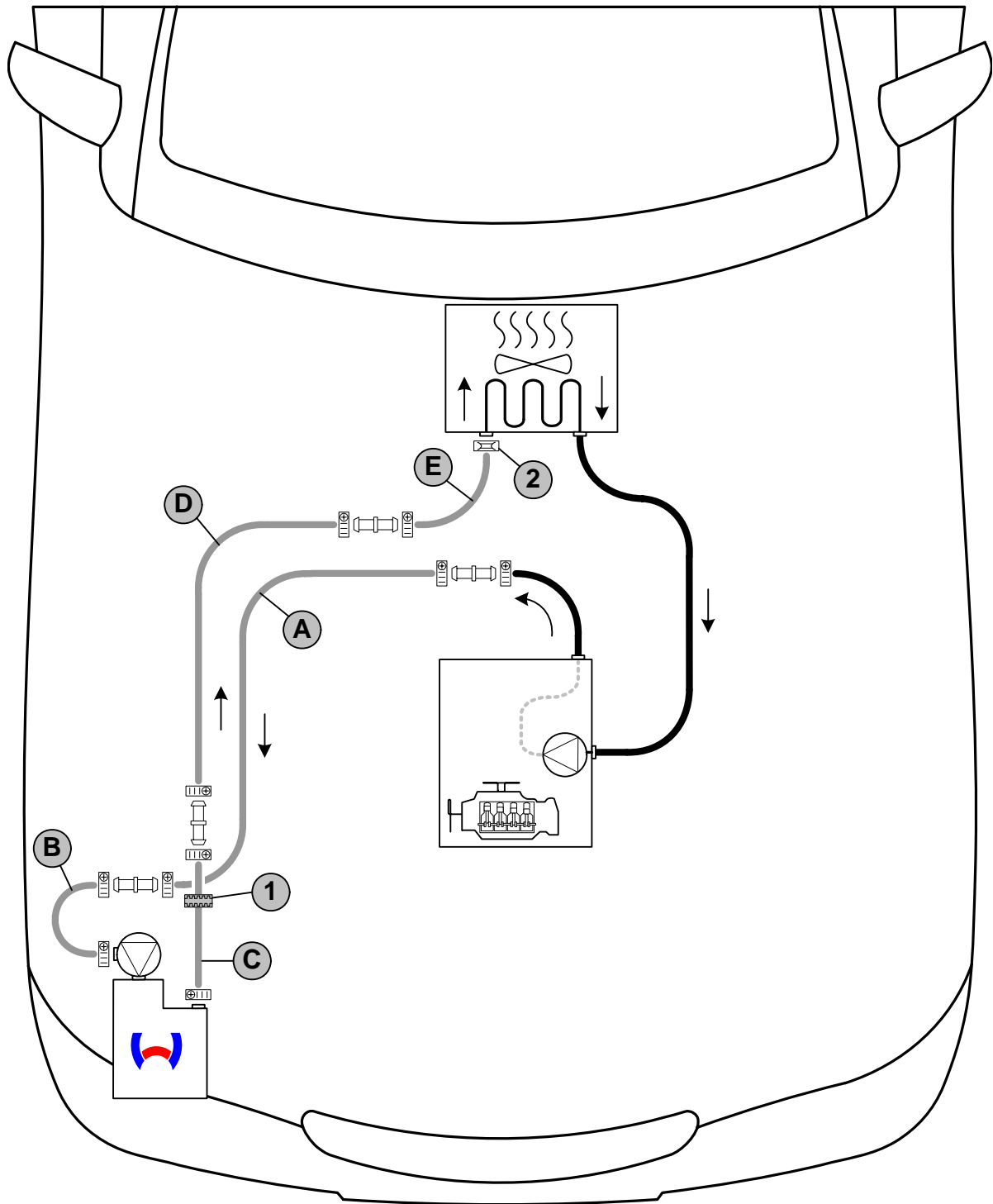

Coolant routing diagram

All hose clamps = 20-27 mm dia.! **1** = Black (sw) rubber profile . **2** = Original vehicle spring clip . All connecting pipes without a specific designation = dia. 15x20.



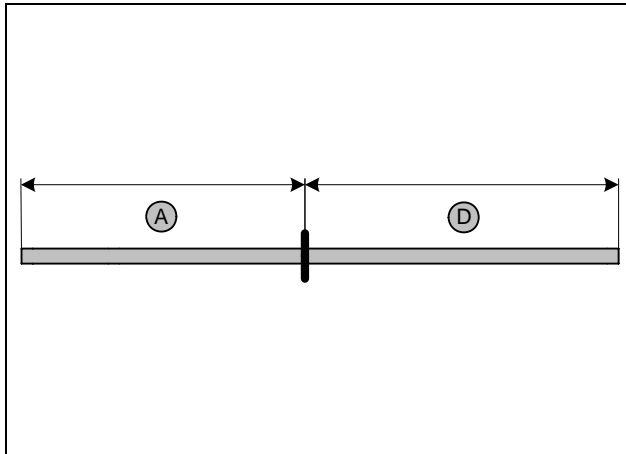

a = 1200
d = 1200

Discard section X

Cutting 15 mm dia. coolant hose to length

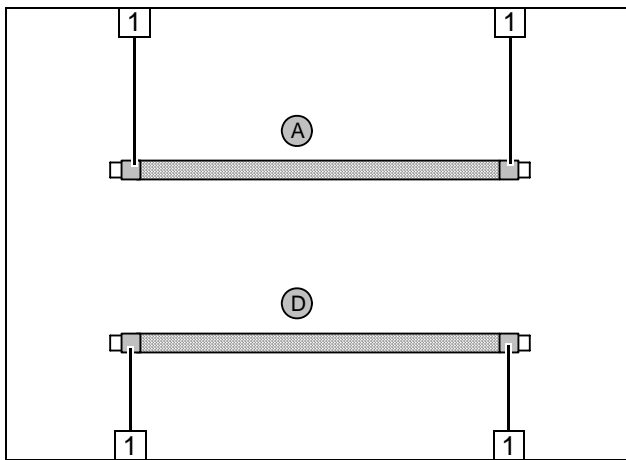

Push braided protection hoses onto hose A and D, cut to length and shrink.



1 Heat shrink plastic tubing [4x]

Premounting coolant hoses

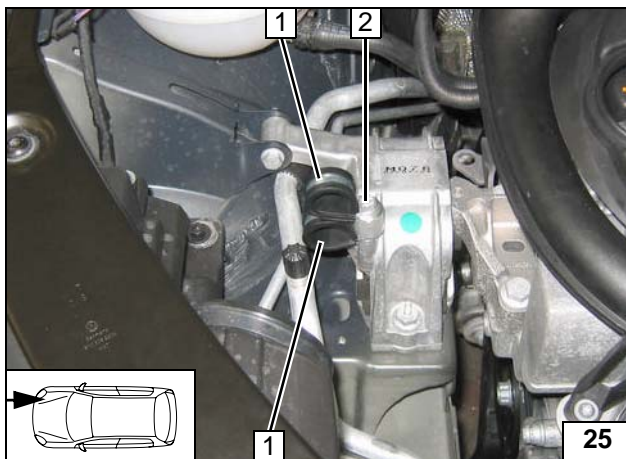

1 25 mm dia. rubber-coated p-clamp [2x]
2 M6x40 bolt, spring lockwasher, 20 mm, existing threaded hole

Preparing installation of coolant hoses

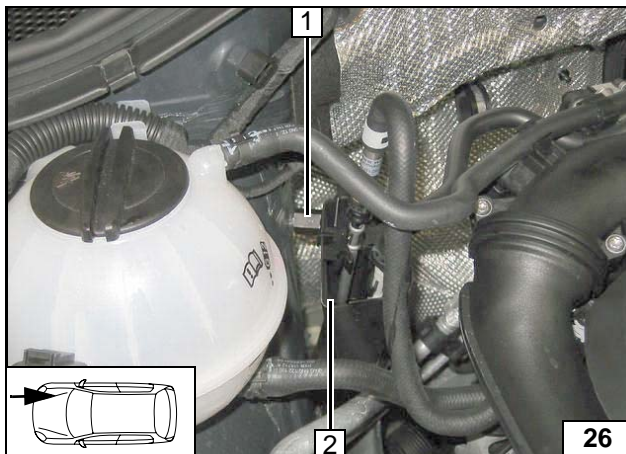

Detach plastic duct 2 and dispose of original vehicle nut.



1 M6x20 spacer nut, M6x12 bolt, spring lockwasher, large diameter washer

Preparing installation of coolant hoses

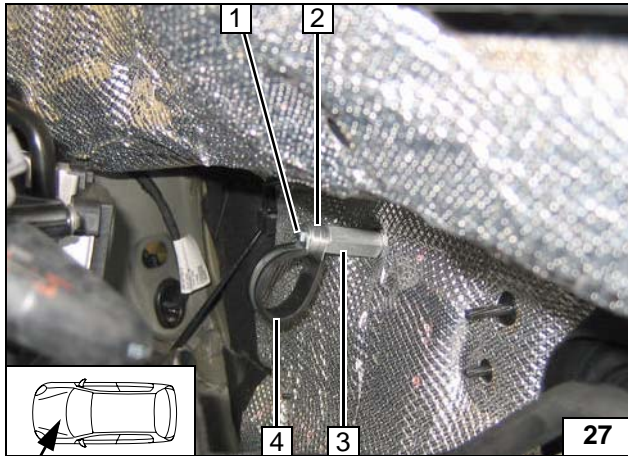
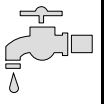

Position 10 mm shim **2** between 34 mm dia. rubber-coated p-clamp **4**.

- 1** M6x20 bolt, spring lockwasher
- 3** M6x40 spacer nut on existing thread



Preparing installation of coolant hoses

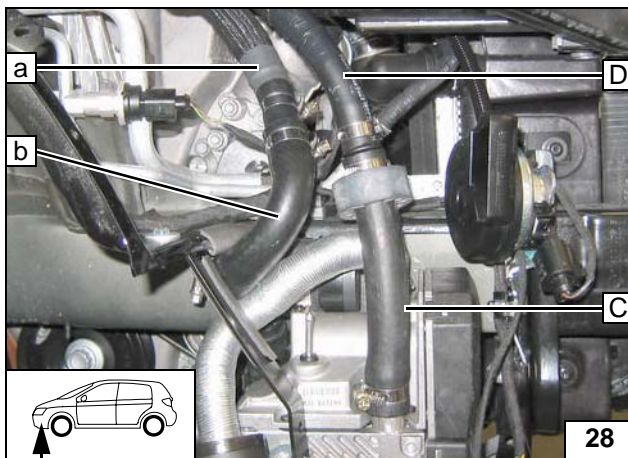

Connection to heater unit

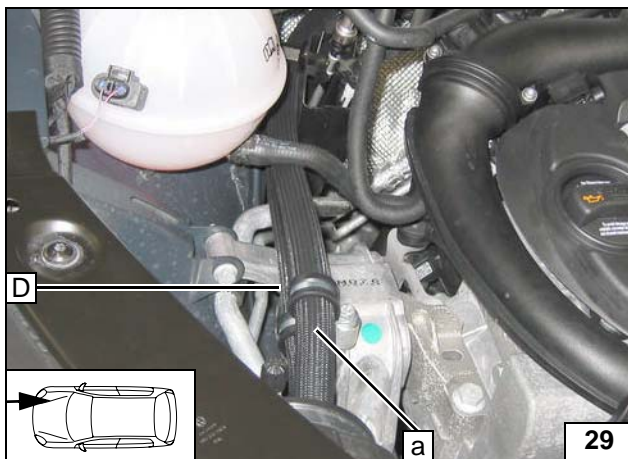

Routing in engine compartment

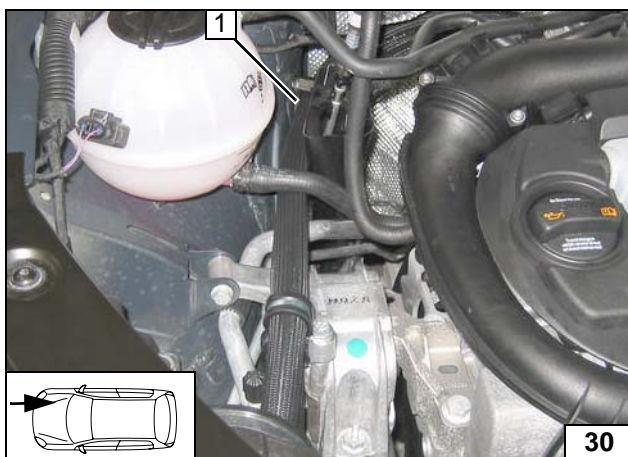

Push through hoses **A** and **D** between body and plastic duct at position **1**.



Routing in engine compartment

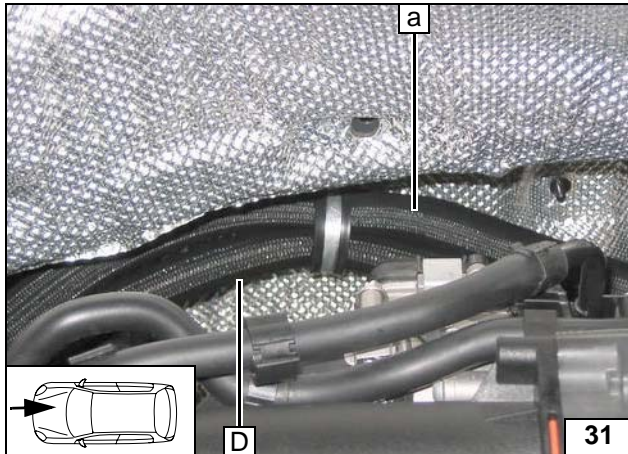
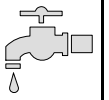

Routing in engine compartment

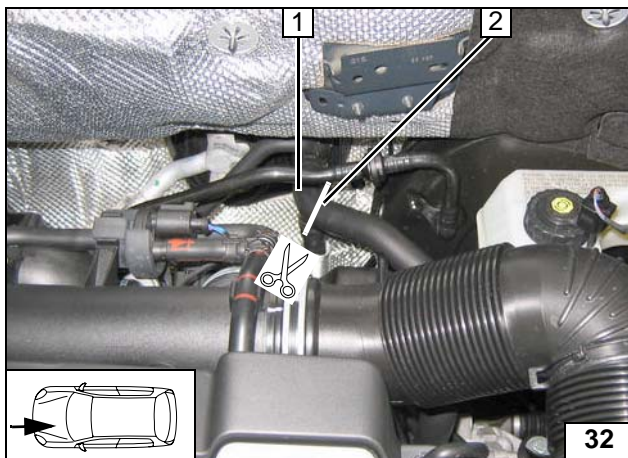

1.4 TSI

Dispose of hose section 1.
Original vehicle clamp will be reused.

2 Cutting point



Cutting point

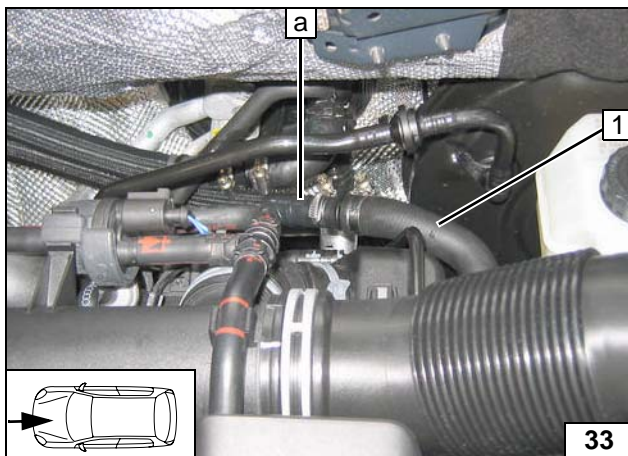

Ensure sufficient distance to neighboring components.

1 Hose of engine outlet



Connecting engine outlet

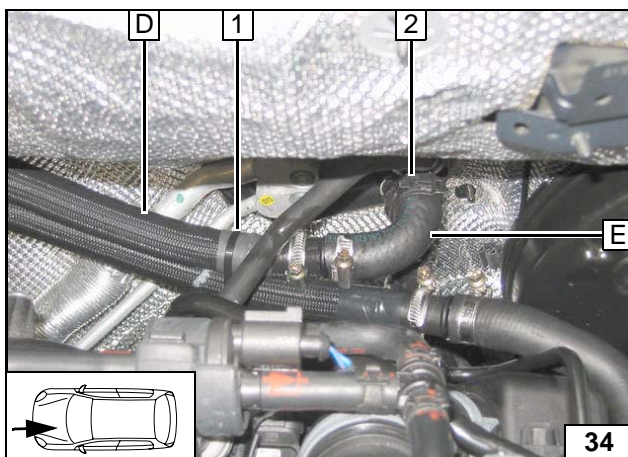

1 Cable tie

2 Original vehicle spring clip

Connecting heat exchanger inlet

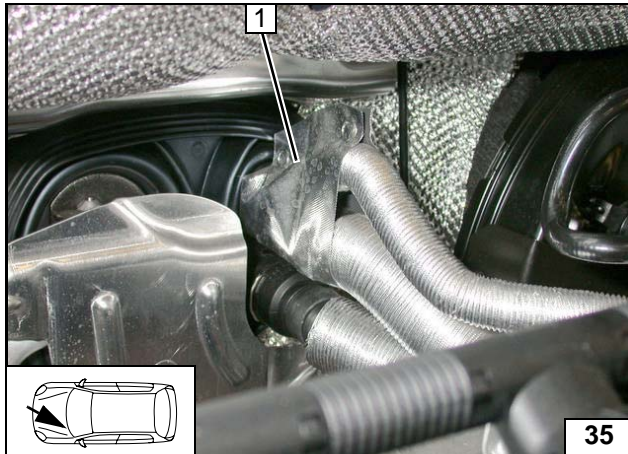
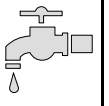

2.0 TSI

Remove trim of heat exchanger inlet/output **1** and discard.



Cutting point

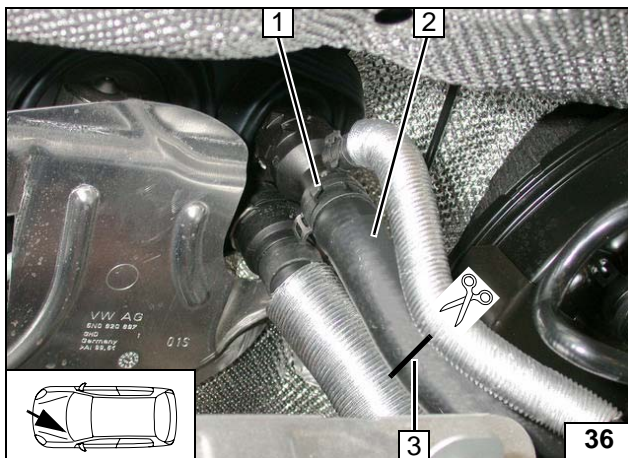

Slide back heat shield on hose on heat exchanger inlet/engine outlet.
Dispose of hose section **2**.
Original vehicle clamp **1** will be reused.



3 Cutting point

Cutting point

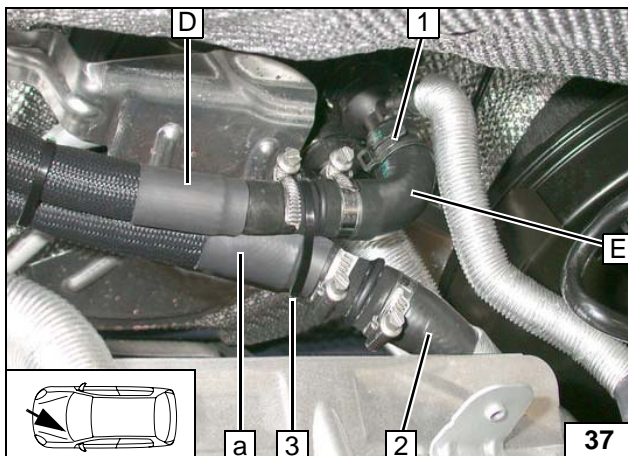

Slide heat shield on hose on engine outlet **2** forward again. Ensure sufficient distance to neighboring components.



- 1** Original vehicle spring clip
- 3** Cable tie

**Conne-
ction on en-
gine outlet
and heat
exchanger
inlet**

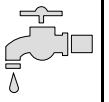

Coolant on 2.0 liter TDI





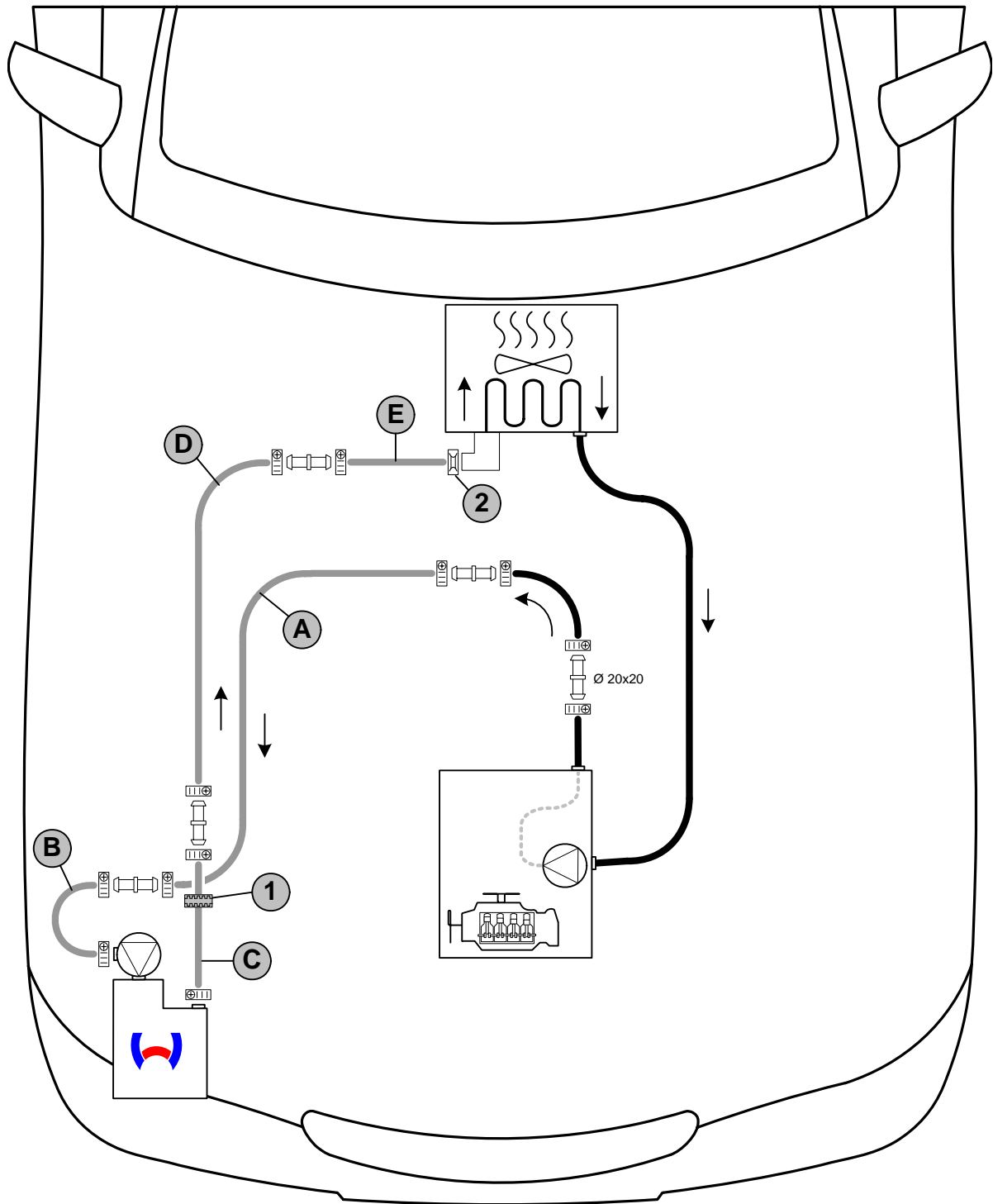

WARNING!

Any coolant running off should be collected using an appropriate container! Route coolant hoses kink-free! Unless specified otherwise, always fasten using cable ties. Position clamps so that no other hose can be damaged! When installing the coolant hose, the heater unit must be filled with coolant. The connection should be "inline" based on the following diagram:



Coolant routing diagram

All hose clamps  = 20-27 mm dia.! **1** = Black (sw) rubber profile  . **2** = Original vehicle spring clip  . All connecting pipes without a specific designation  = dia. 15x20.



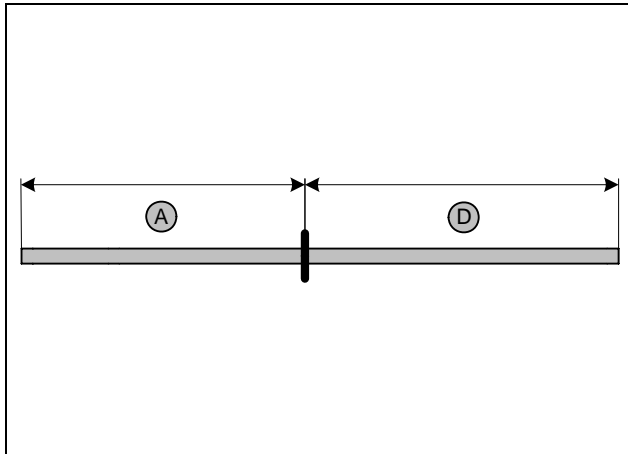

a = 1,050
d = 1200

Discard section X

Cutting 15 mm dia. coolant hose to length

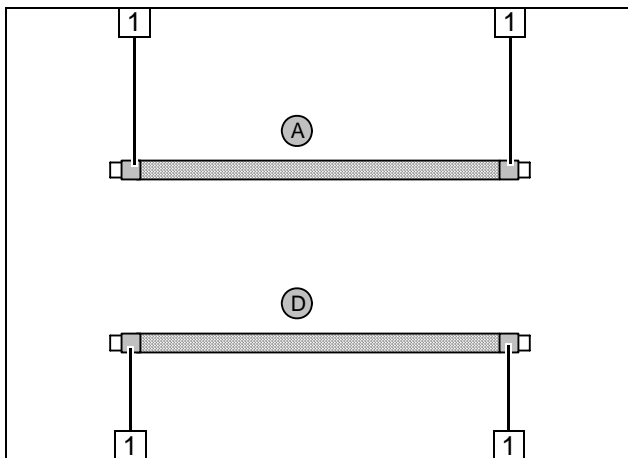

Push braided protection hoses onto hose A and D, cut to length and shrink.



1 Heat shrink plastic tubing [4x]

Premounting coolant hoses

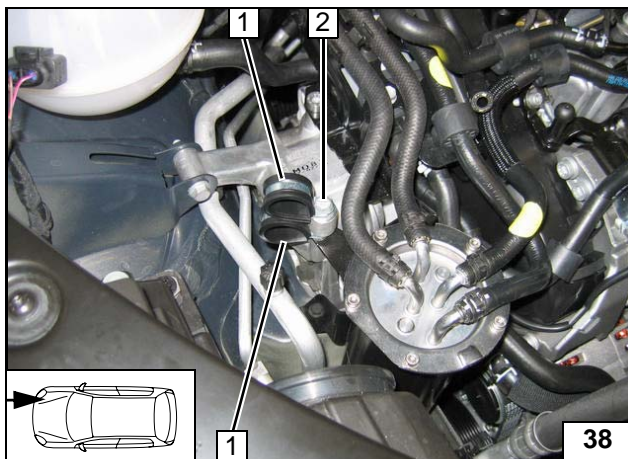

Remove original vehicle bolt at position 2 and discard.



1 25 mm dia. rubber-coated p-clamp [2x]
2 M6x40 bolt, spring lockwasher, 20 mm shim

Preparing installation of coolant hoses

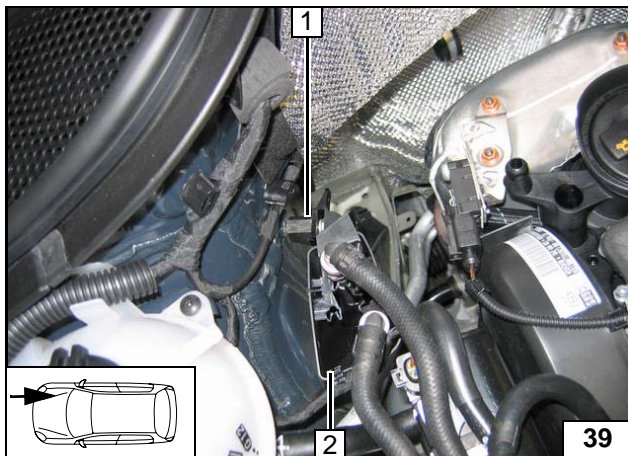

Detach plastic duct 2 and dispose of original vehicle nut.



1 M6x20 spacer nut, M6x12 bolt, spring lockwasher, large diameter washer

Preparing installation of coolant hoses

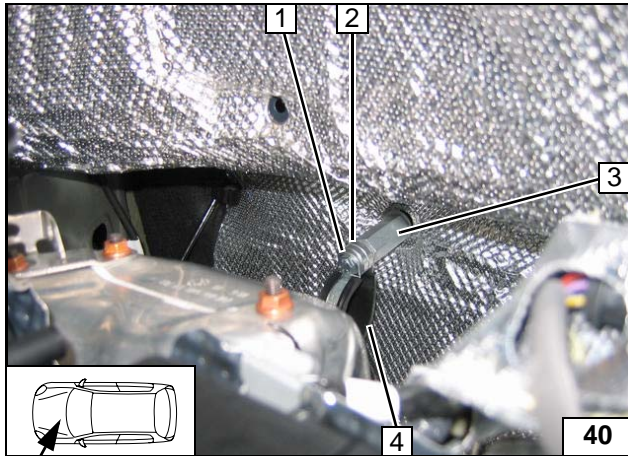
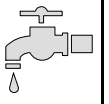

Position 10 mm shim **2** between 34 mm dia. rubber-coated p-clamp **4**.

- 1** M6x20 bolt, spring lockwasher
- 3** M6x40 spacer nut on existing thread



Preparing installation of coolant hoses

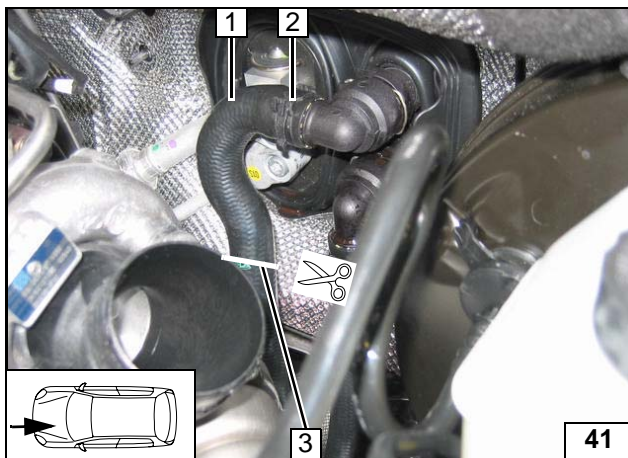

Hose section **1** and original vehicle clamp **2** will be reused.

- 2** Cutting point



Cutting point

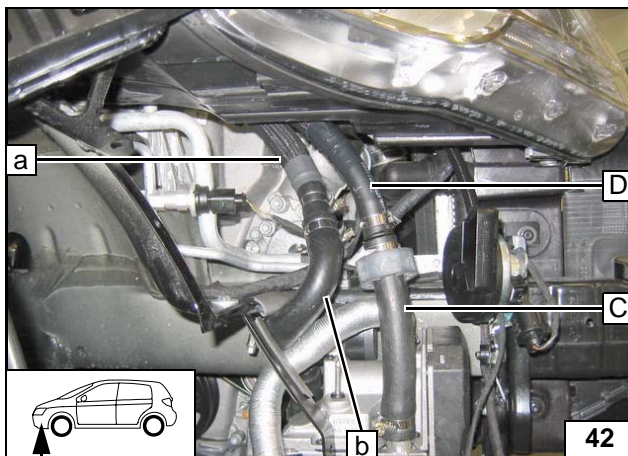

Connection to heater unit

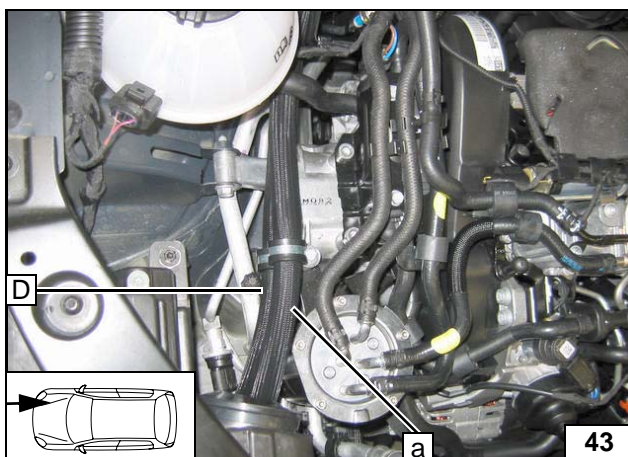

Routing in engine compartment

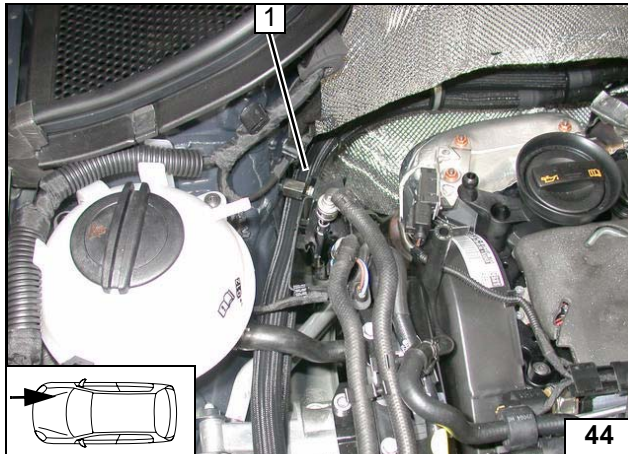
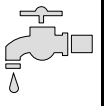

Push through hoses **A** and **D** between body and plastic duct at position **1**.



Routing in engine compartment

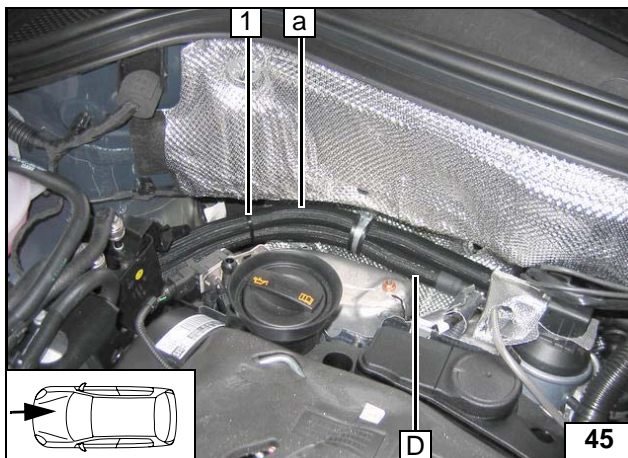

1 Cable tie

Routing in engine compartment

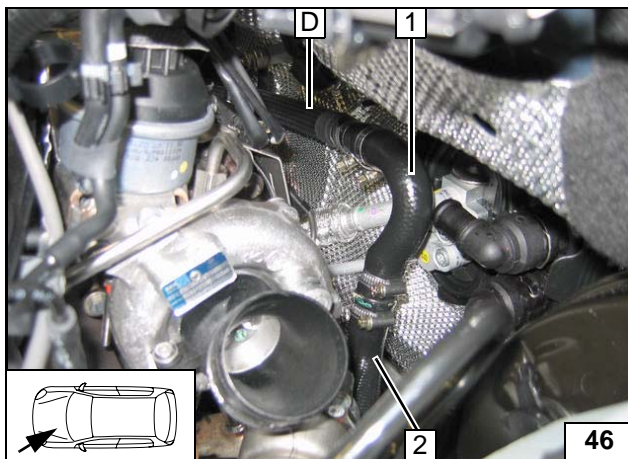

1 Hose section turned by 180°
2 Engine outlet hose section

Connecting engine outlet

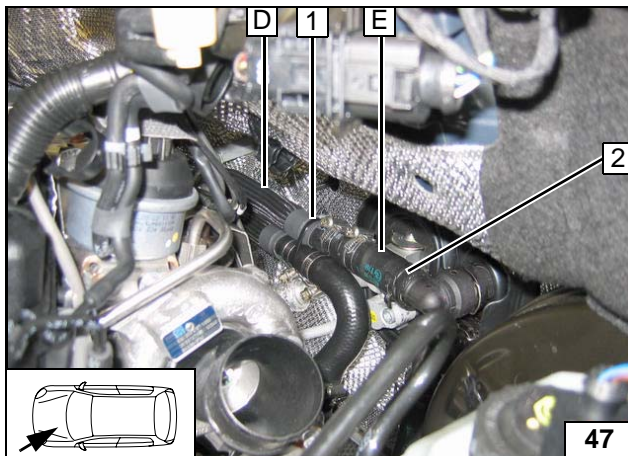

Ensure sufficient distance to neighboring components.

1 Cable tie
2 Original vehicle spring clip



Connecting heat exchanger inlet



Fuel Connection

CAUTION!

Open the vehicle's fuel tank cap, ventilate the tank and then re-close the tank lock.

Catch any fuel running off with an appropriate container.

Install fuel line and metering-pump wiring harness so that they are protected against stone impact. Unless specified otherwise, always fasten using cable ties. Mount the fuel line and wiring harness with rub protection on sharp edges.

WARNING!

The fuel line and wiring harness are routed to the metering pump in as shown in the wiring harness routing diagram.

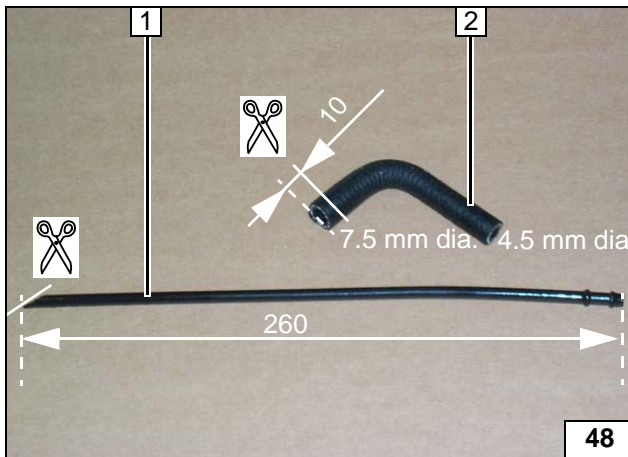

- 1 Standpipe
- 2 Molded hose

Cutting standpipe and molded hose to length

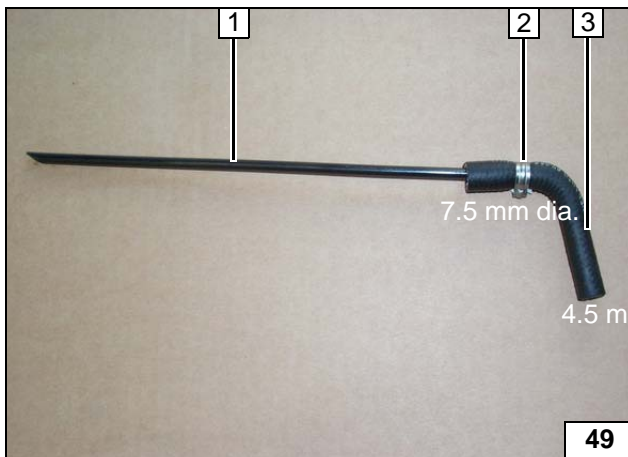

Caillau clamp 2 in center between beads on end of standpipe.

- 1 Standpipe
- 2 10 mm dia. Caillau clamp
- 3 Molded hose

Pre-mounting standpipe and molded hose

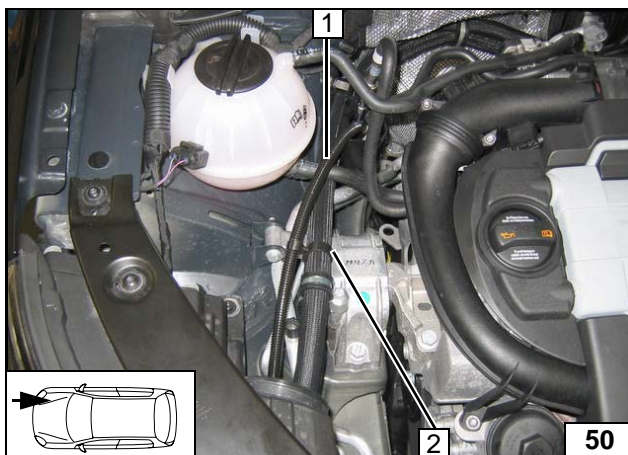

Cut corrugated tube 1 to length of 650 mm, pull in fuel line and wiring harness of metering pump and route along original vehicle lines to installation location of metering pump.

- 2 Line holder

Routing fuel line and wiring harness of metering pump

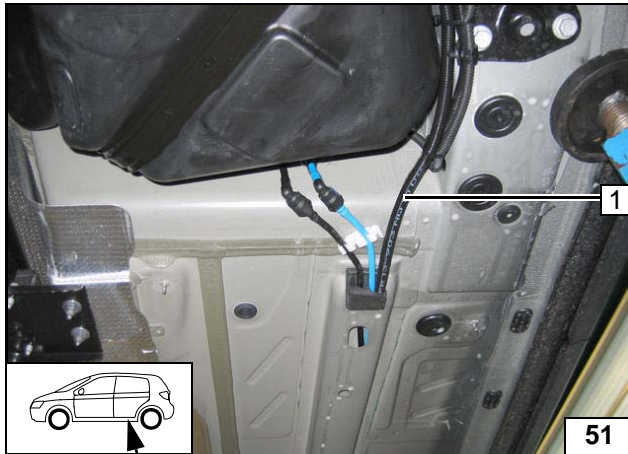

1 Fuel line and wiring harness for metering pump in corrugated tube

Routing fuel line and wiring harness of metering pump

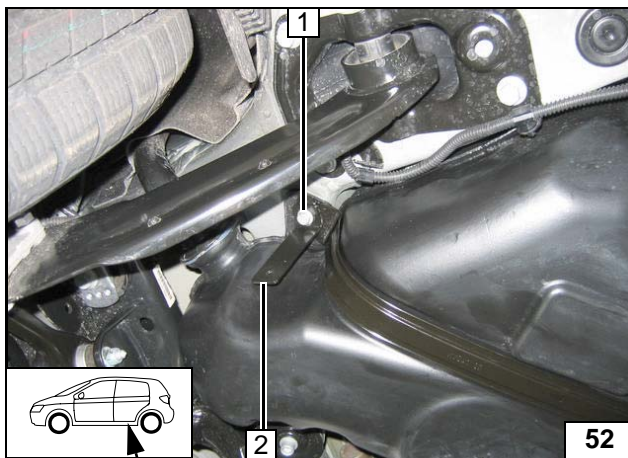

1 Original vehicle bolt
2 Bracket of metering pump

Installing metering pump

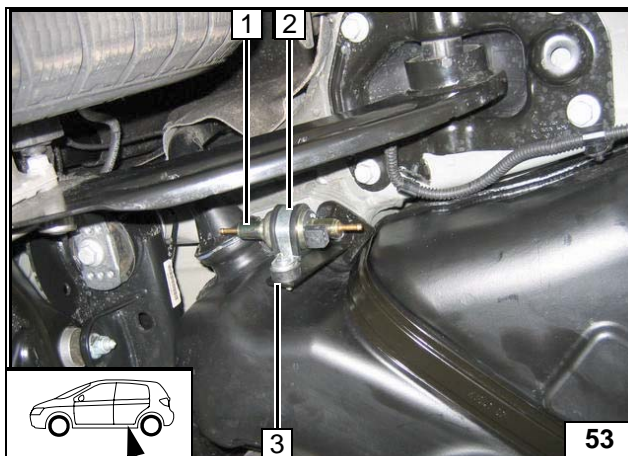

1 Metering pump
2 Rubber-coated pipe clamp
3 Noise isolation mounts, flanged nut M6 [2x]

Installing metering pump

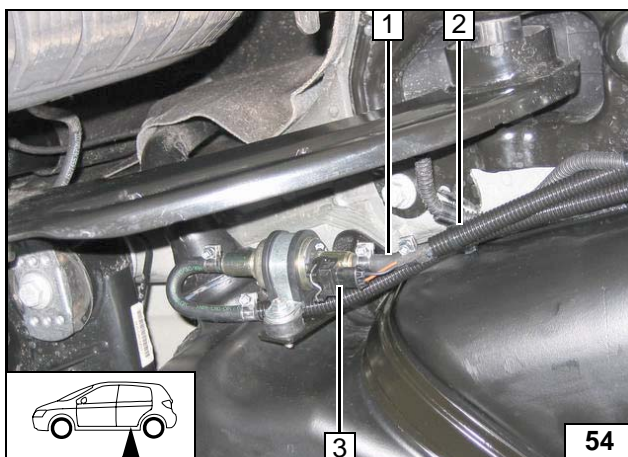

1 Hose section, 10 mm dia. hose clamp [2x]
2 Fuel line and wiring harness for metering pump in corrugated tube
3 Wiring harness of metering pump, connector mounted



Mounting metering pump and connecting pressure side

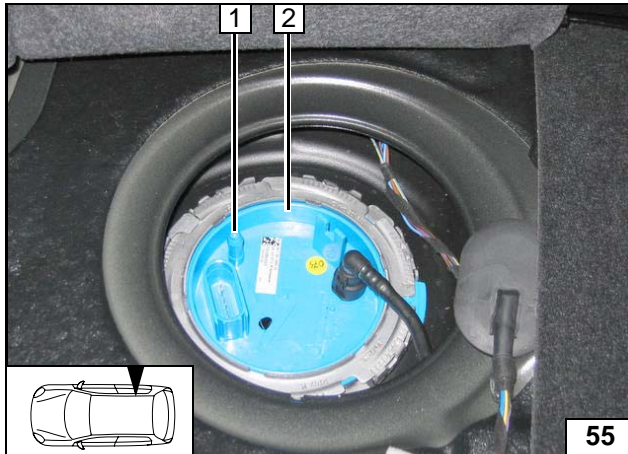

1.4 liter TSI only

- 1 Remove 3 mm blind plug
- 2 Fuel-tank sending unit



Cutting off blind plug

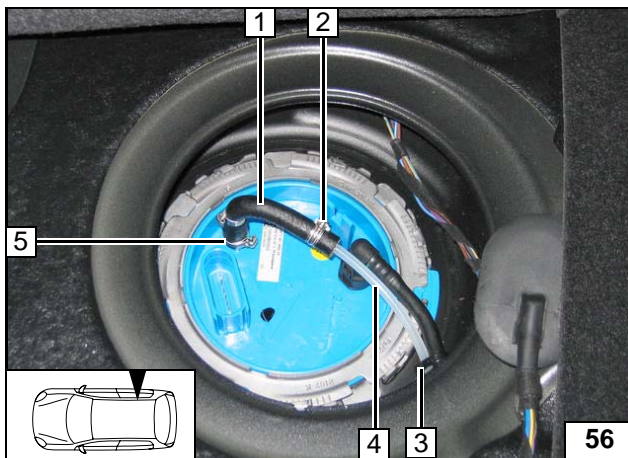

- 1 Preassembled molded hose with stand-pipe
- 2 10 mm dia. Caillau clamp
- 3 Cable tie
- 4 Fuel line
- 5 13.5 mm dia. Caillau clamp



**Connec-
tion to fuel-
tank send-
ing unit**

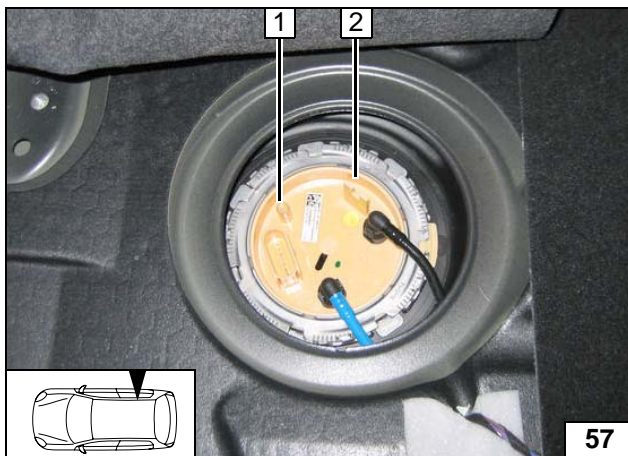

2.0 liter TDI only

- 1 Remove 3 mm blind plug
- 2 Fuel-tank sending unit



Cutting off blind plug

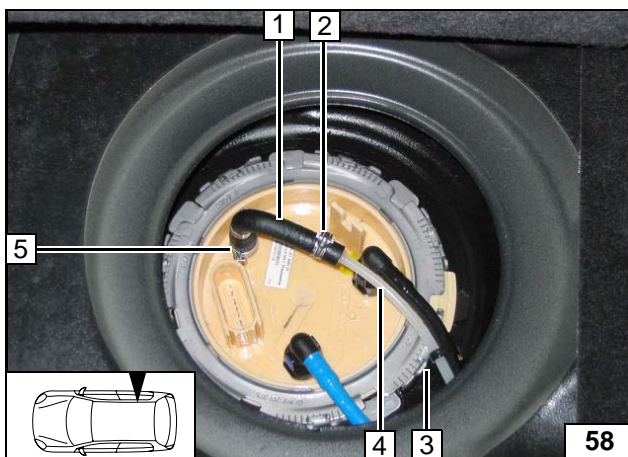

- 1 Preassembled molded hose with stand-pipe
- 2 10 mm dia. Caillau clamp
- 3 Cable tie
- 4 Fuel line
- 5 13.5 mm dia. Caillau clamp



**Connec-
tion to fuel-
tank send-
ing unit**

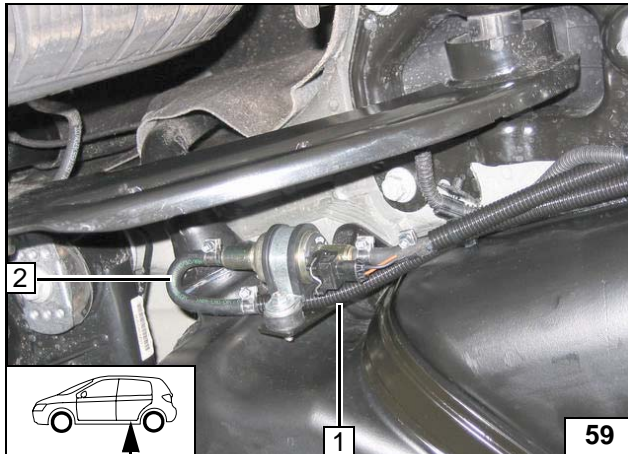
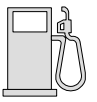

All vehicles

Before installation, pull fuel line into remaining section of corrugated tube **1**.

2 Molded hose, 10 mm dia. hose clamp [2x]



**Connect-
ing intake
side of me-
tering
pump**

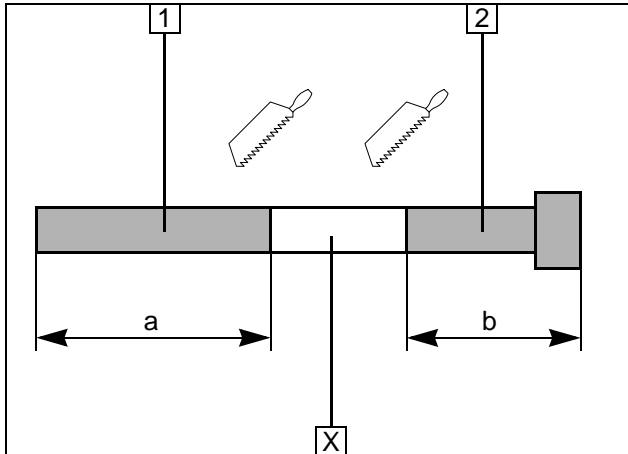
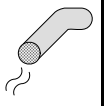

Exhaust gas

- 1 Exhaust pipe
a = 150
- 2 Exhaust end section
b = 90

Discard section X

Preparing exhaust pipe

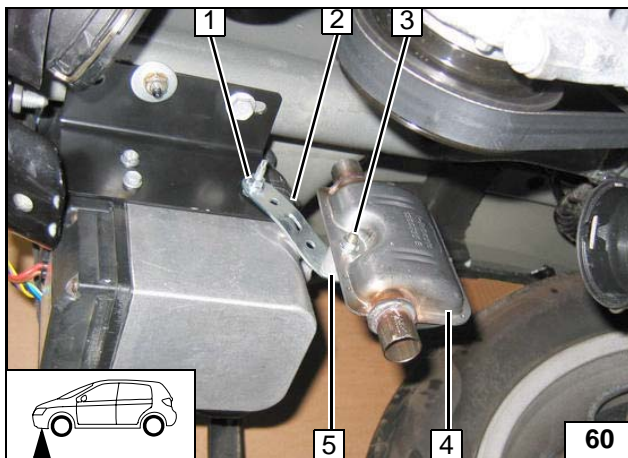

Align exhaust muffler 4 following installation as shown.

- 1 M6 flanged nut
- 2 Perforated bracket
- 3 M6x35 bolt, M6 flanged nut
- 5 20 mm shim



Mounting muffler

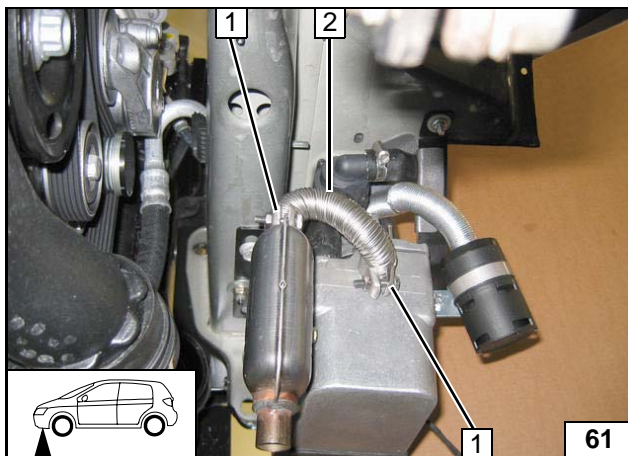

- 1 Hose clamp [2x]
- 2 Exhaust pipe

Installing exhaust pipe

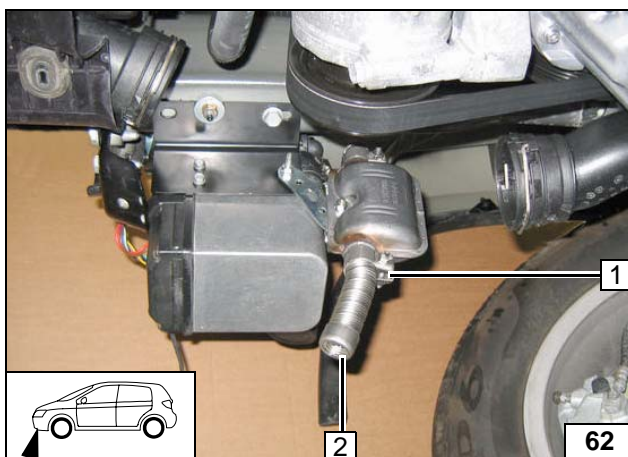

- 1 Hose clamp
- 2 Exhaust end section

Installing exhaust end section

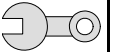

Final Work

WARNING!

Mount removed parts in reverse order.

Check all hoses, clamps and all electrical connections for firm seating.

Secure all loose cables using cable ties.

Only use manufacturer-approved coolant.

Spray heater unit components with anti-corrosion wax (Tectyl 100K, Order No. 111329).

- Connect the battery.
- Fill and bleed the coolant circuit according to the vehicle manufacturer's specifications.
- Set the digital timer.
- Make settings on A/C control panel according to the "Operating Instructions for End Customer".
- Check the proper operation of the additional heater, see the operating instructions/installation instructions.
- Attach the "Switch off additional heater before refueling" sticker to the left-hand B-pillar.

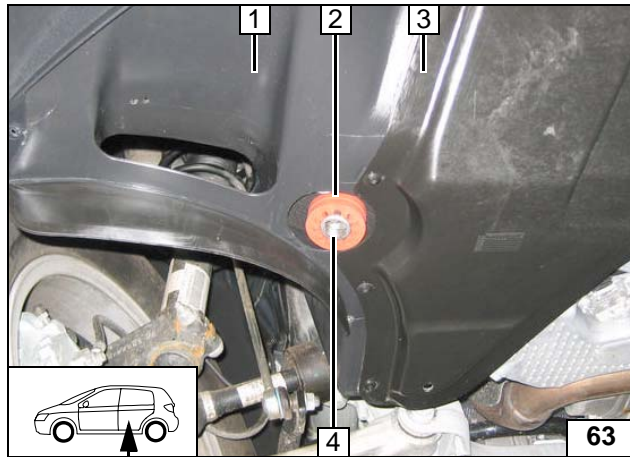

Align exhaust end section 4 flush on red rubber isolator 2.

- 3 Wheel well trim
- 3 Underride protection

**Mounting
rubber iso-
lator**



Webasto AG
Postfach 80 - 82132 Stockdorf
Hotline 01805 / 932278 - Hotfax 0395 / 5592-353
<http://www.webasto.de>

Operating Instructions for End Customer



Please remove page and add to the vehicle operating instructions.



Note:

We recommend matching the heating time to the driving time.

Heating time = driving time

Example:

For a driving time of approx. 20 min. (in one direction), we recommend not exceeding a switch-on time of 20 min.

If the summer/winter switch option has been installed, this must be switched in accordance with the time of year. The heater unit will then only switch on the vehicle fan to ventilate the vehicle interior in the position Winter  heat and in the position Summer .



Before parking the vehicle, make the following settings:



- 1 Set temperature to "HI" [2x]
- 2 Air outlet faces upward

Climatron-ic