

# Water Heater Unit



**Thermo Top E Additional Heater** e1 00 0003

**Thermo Top C Additional Heater** e1 00 0002

**Thermo Top P Additional Heater** e1 00 0104

## Installation Instructions

### Nissan Tiida

Gasoline

from Model Year 2008

Left-hand drive vehicle

not checked:

- Automatic transmission
- Xenon headlamp with washer system



#### **WARNING!**

Hazard warning:

Incorrect installation or repair of Webasto heating systems may cause a fire or result in the emission of carbon monoxide, which can be fatal. Serious or fatal injuries can be caused as a result.

Specialist company training, technical documentation, specialized tools and equipment are required to install and repair Webasto heating and cooling systems.

NEVER attempt to install or repair Webasto heating or cooling systems if you have not successfully completed the company training and thereby acquired the required technical skills, or if you do not have access to the required technical documentation, tools and equipment needed to carry out correct installation and repairs.

ALWAYS follow all Webasto installation and repair instructions and observe all warnings.

Webasto does not accept any liability for defects and damage that are attributable to installation by untrained staff.

**Table of Contents**

Validity	2	Preparing installation location	11
Heater Unit/Installation Kit	3	Preparing heater unit	12
Foreword	3	Installing heater unit	12
General Instructions	3	Coolant, 1.6 liter engine	14
Special Tools	3	Coolant, 1.8 liter engine	17
Explanatory Notes on Document	4	Combustion air	20
Preliminary Work	5	Fuel	21
Heater unit installation location	5	Exhaust gas	24
Electrical system	6	Final Work	25
Fan controller for manual air conditioning	7	Template for Fuel Standpipe	26
Automatic air-conditioning fan controller	8	Drilling Template	27
Digital timer / summer/winter switch option	10	Operating Instructions for End Customer	28
Remote option (Telestart)	10		

**Validity**

Manufacturer	Model	Type	EG-BE No./ABE
Nissan	Tiida	C11	e11 * 2001/116 * 0296.

Engine type	Engine model	Output in kW	Displacement in cm <sup>3</sup>
HR16	Gasoline	81	1598
MR18	Gasoline	93	1798

Vehicle and engine types, equipment variants and national specifications not listed in these installation instructions have not been tested. However, installation according to these installation instructions may be possible.

The installation location of a digital timer and summer/winter switch should be confirmed with the end customer before installation.

**Heater Unit/Installation Kit**

Quantity	Description	Order No.:
1	Nissan-specific retail accessories	See Nissan price list
1	Heater control	See Nissan price list
1	Installation Kit for NissanTiida Gasoline	1313258A

**Heater unit recommended for the respective vehicle class:**

Vehicle	Heater unit
Compact car	Thermo Top E
Mid-size car, station wagon	Thermo Top C
Full-size car, van, offroader	Thermo Top P

The selection of the heater unit is based on the passenger compartment size of the vehicle and the level of comfort required by the customer!



**Foreword**

These installation instructions apply to Nissan Tiida Gasoline vehicles - for validity, see page 2 - from model year 2008 and later, assuming technical modifications to the vehicle do not affect installation, any liability claims excluded. Depending on the vehicle version and equipment, modifications may be necessary during installation with respect to these installation instructions.

However, the stipulations in the "installation instructions" and "operating and maintenance instructions" for the *Thermo Top C/P/E* must always be observed.

The corresponding rules of technology and any information from the vehicle manufacturer should be observed during the installation work.

**General Instructions**

Installation should be carried out according to the general, standard rules of technology. Unless specified otherwise, fasten hoses, lines and wiring harnesses to original vehicle lines and wiring harnesses using cable ties.

Sharp edges should be fitted with edge protectors (split-open plastic hose).

Spray unfinished body areas, e.g. drilled holes, with anti-corrosion wax (Tectyl 100K, Order No. 111329).

**Special Tools**

- Torque wrench for 2.0 - 10 Nm
- Hose clamping pliers
- Metric thread-setter kit

**Explanatory Notes on Document**

To provide you with a quick overview of the individual working steps, you will find an identification mark on the outside top right corner of the page in question.

**Mechanical system**

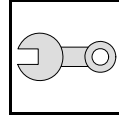

**Electrical system**

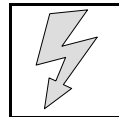

**Water**

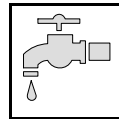

**Fuel**

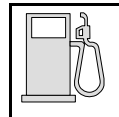

**Exhaust gas**

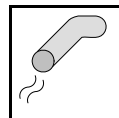

**Combustion air**

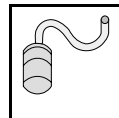

Special features are highlighted using the following symbols:



Specific risk of injury or fatal accidents.



Specific risk of damage to components.



Specific risk of fire or explosion.



Reference to general installation instructions of Webasto components or to the manufacturer's vehicle-specific documents.



Reference to a special technical feature.



The arrow in the vehicle icon indicates the position on the vehicle and the viewing angle.

**All dimensions are in mm!**

**Tightening torque of hose clamps = 2.0 + 0.5 Nm!**

**Tightening torque of Ejet screws, Ejet studs = 10 Nm!**

## Preliminary Work

### WARNING!

- Open fuel tank cap, ventilate tank.
- Close the tank cap again.
- Disconnect the battery "earth" or "ground" connection.
- Depressurize the cooling system.
- Copy the factory number from the original type label to the duplicate type label.
- Remove years that do not apply from the duplicate label.
- Attach the duplicate label (type label) in the appropriate place.
- Completely remove the battery.
- Remove the air filter together with the intake hose.
- Remove the left front wheel.
- Detach the wheel well trim on the left
- Remove the bumper.
- Remove the underride protection
- Remove the rear bench seat.
- Open the right-hand fuel sender service lid.
- Remove the left-hand instrument panel trim.
- Remove the fuse and relay carrier on the left.
- Remove the A/C control panel according to the manufacturer's instructions (only with automatic air-conditioning).

Remove page 28 "Operating Instructions for End Customer" and add to the vehicle operating instructions.

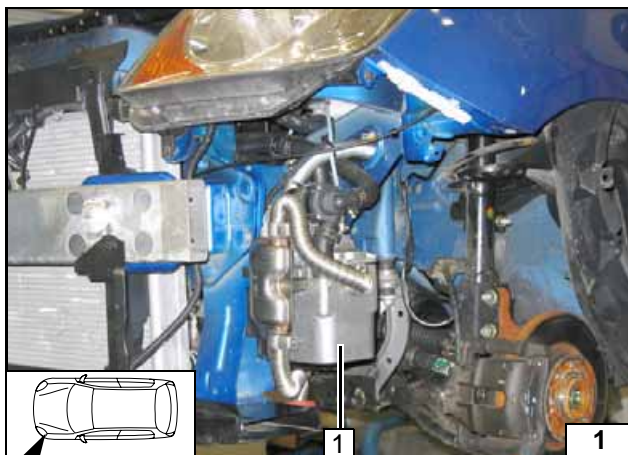

### Heater unit installation location

- 1 Heater unit

Installation location



**Electrical system**

**Positive connection**

1 Positive distribution of battery

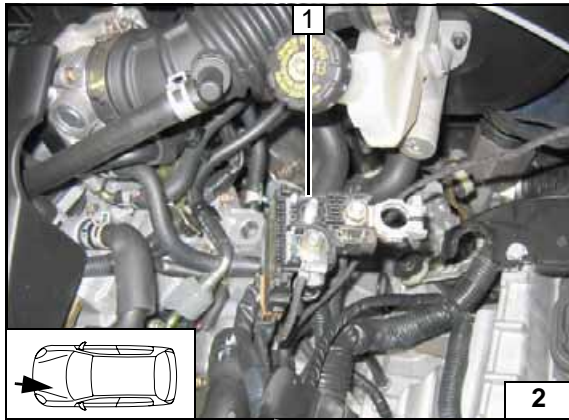

**Wiring harness pass through**

1 Pass through into passenger compartment

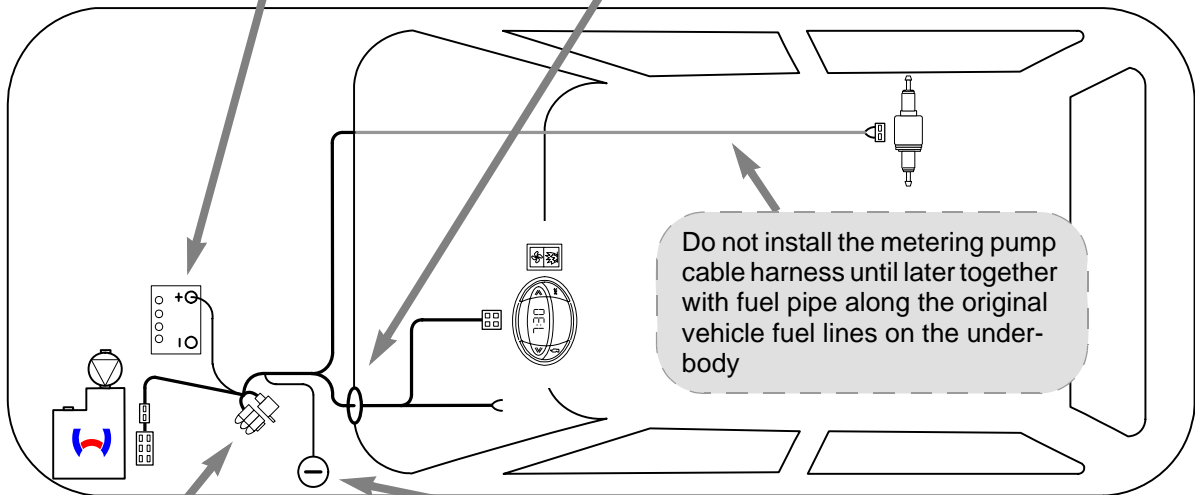
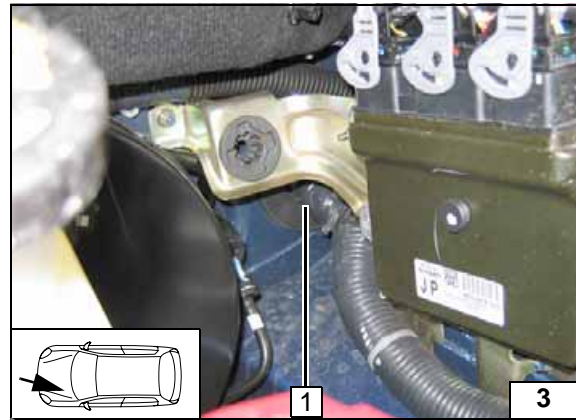

**Wiring harness installation diagram**

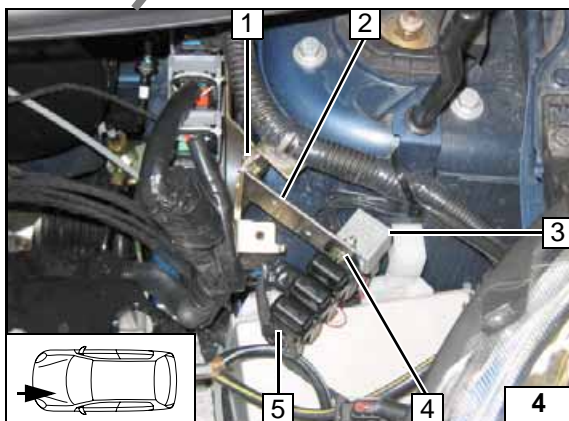

**Fuse holder, relay K3**

- 1 7 mm dia. hole, M6x20 bolt, M6 flanged nut
- 2 Fuse holder
- 4 Retaining plate, M5x16 bolt, large diameter washer, K3 relay 3, M5 flanged nut
- 5 Fuse holder

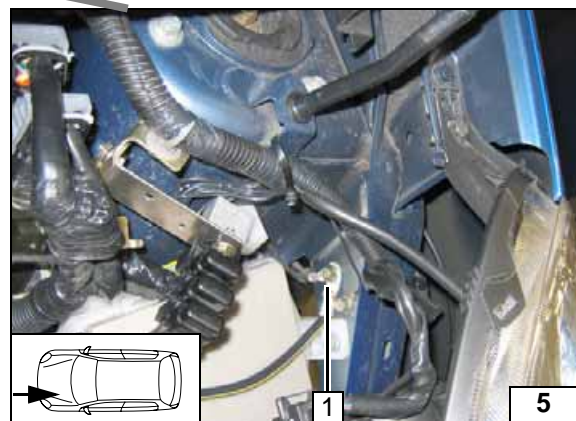

**Ground connection**

- 1 Ground support point



Fan controller for manual air conditioning

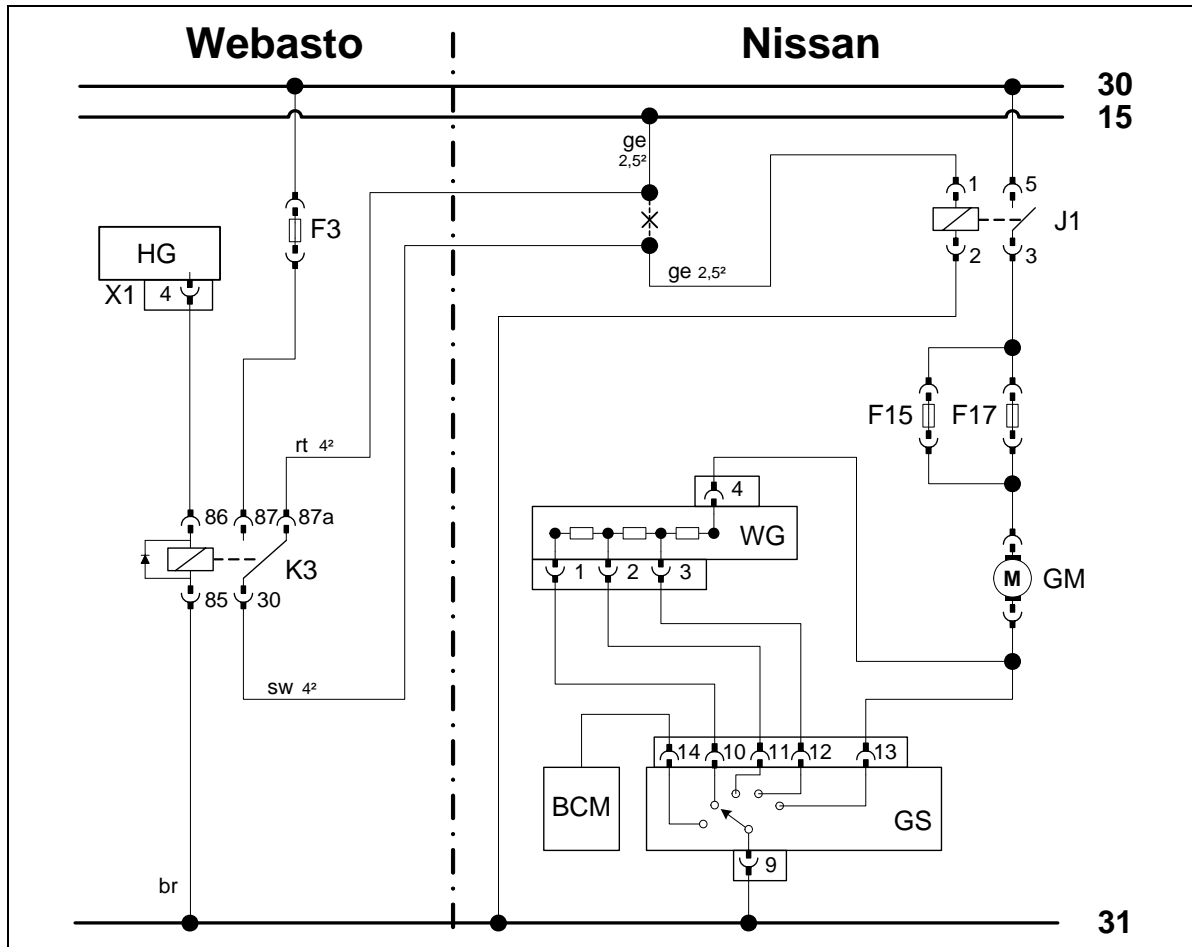

Wiring diagram

Webasto components		Vehicle components		Colors and symbols	
HG	Heater unit TT-C/E	GM	Fan motor	rt	red
X1	6-pin heater unit connector	J1	Fan relay	ws	white
K3	Fan relay	WG	Resistor group	sw	black
F3	Replace 25 A fuse with 10 A fuse	GS	Fan switch	or	orange
		BCM	Body control unit	ge	yellow
		F15	15 A fuse	gn	green
		F17	15 A fuse	X	Cutting point
				Wiring colors may vary.	

Legend

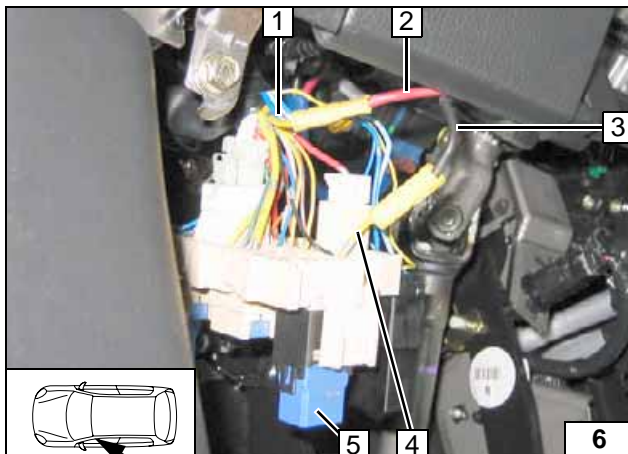

Connection to fan relay 5 behind fuse and relay carrier. Produce connections as shown in wiring diagram.

- 1 Yellow (ge) wire of Terminal 15
- 2 Red (rt) wire from K3/87a
- 3 Black (sw) wire from K3/30
- 4 Yellow (ge) wire J1, Pin 1



Connecting fan-motor



Automatic air-conditioning fan controller

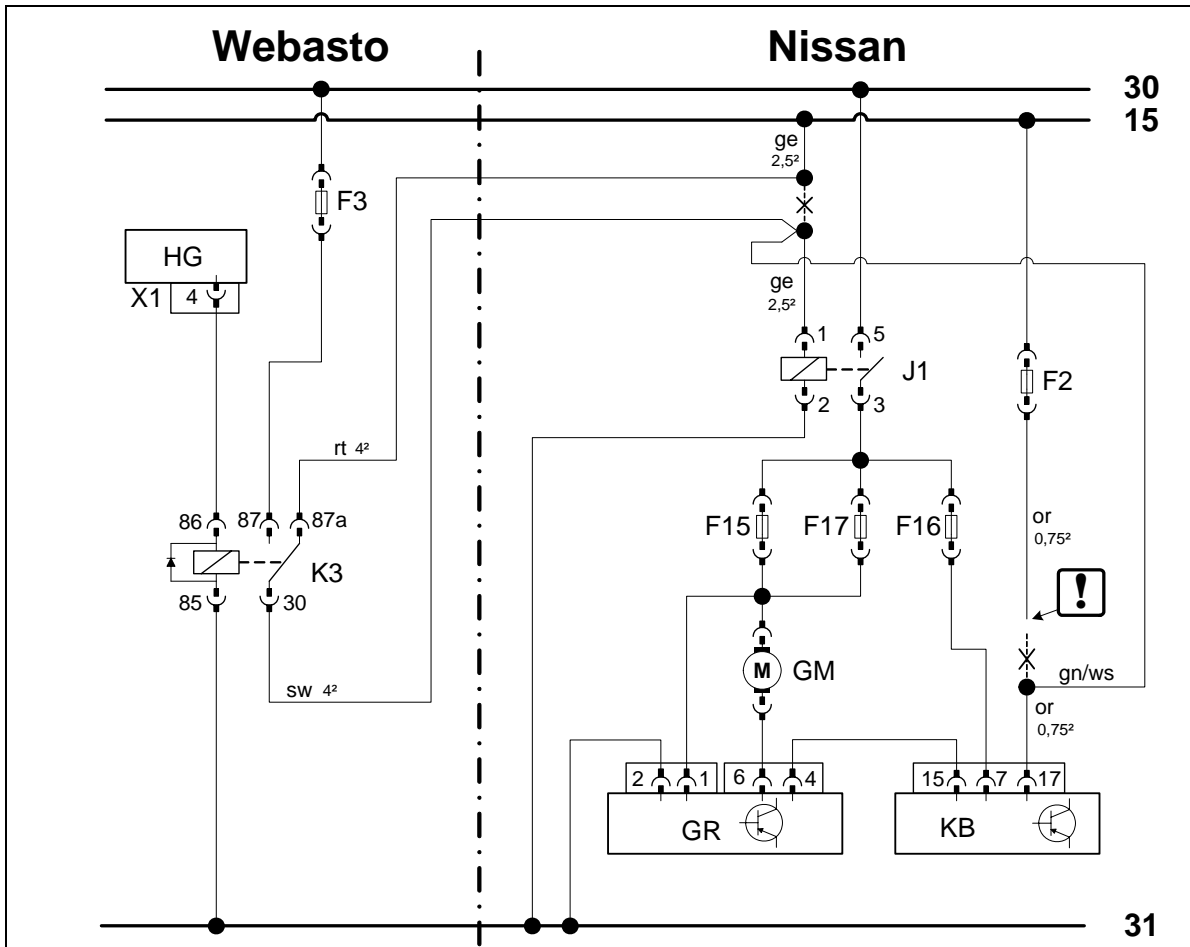

Wiring diagram

Webasto components		Vehicle components		Colors and symbols	
HG	Heater unit TT-C/E	GM	Fan motor	rt	red
X1	6-pin heater unit connector	J1	Fan relay	ws	white
K3	Fan relay	GR	Fan controller	sw	black
F3	Replace 25 A fuse with 10 A fuse	KB	Air-conditioning control panel	or	orange
		F2	10 A fuse	ge	yellow
		F15	15 A fuse	gn	green
		F16	10 A fuse		
		F17	15 A fuse		
					Insulate wire end and tie back
				X	Cutting point
					Wiring colors may vary.

Legend



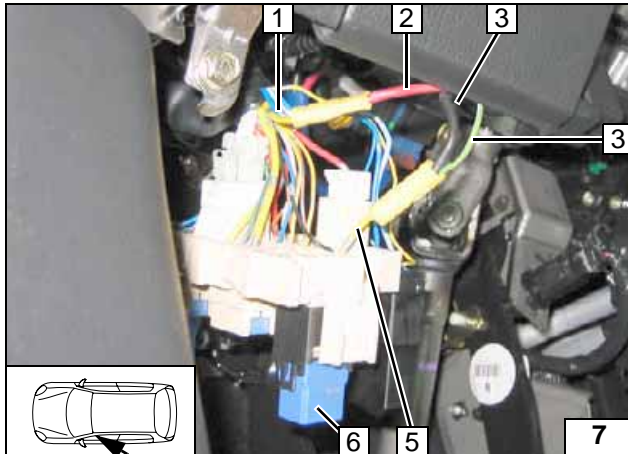

Connection to fan relay **6** behind fuse and relay carrier. Produce connections as shown in wiring diagram.

- 1 Yellow (ge) wire of Terminal 15
- 2 Red (rt) wire from K3/87a
- 3 Black (sw) wire from K3/30
- 4 Green/white (gn/ws) wire from KB
- 5 Yellow (ge) wire of J1, Pin 1



**Connect-  
ing fan-mo-  
tor**

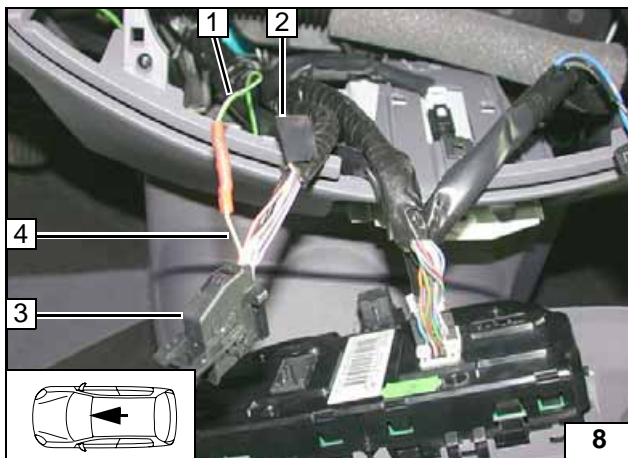

Connection to 18-pin connector **3** from A/C control element. Produce connections as shown in wiring diagram.

- 1 Green/white (gn/ws) wire
- 2 Insulate orange (or) wire of fuse F2 and tie back
- 4 Orange (or) wire to connector of A/C control panel, Pin 17



**Connect-  
ing A/C  
control  
panel**

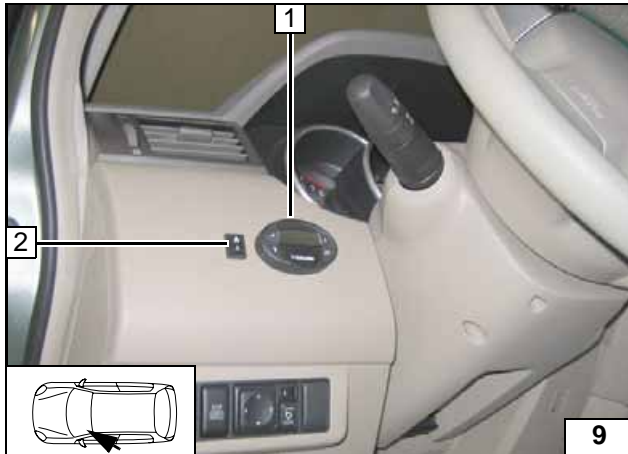

**Digital timer / summer/winter switch option**

- 1 Digital timer
- 2 Summer/winter switch option



**Installing receiver**

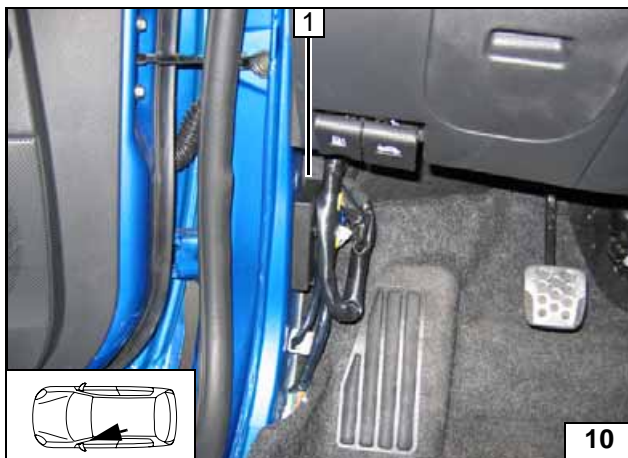

**Remote option (Telestart)**

- 1 Receiver, fasten on left-hand A-pillar with suitable means



**Installing receiver**

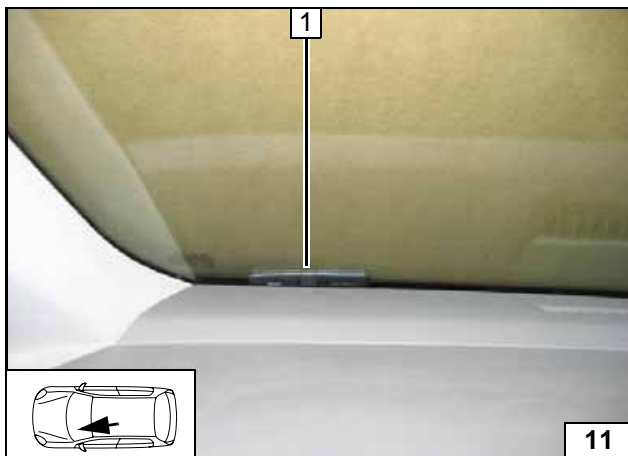

- 1 Antenna

**Installing antenna**

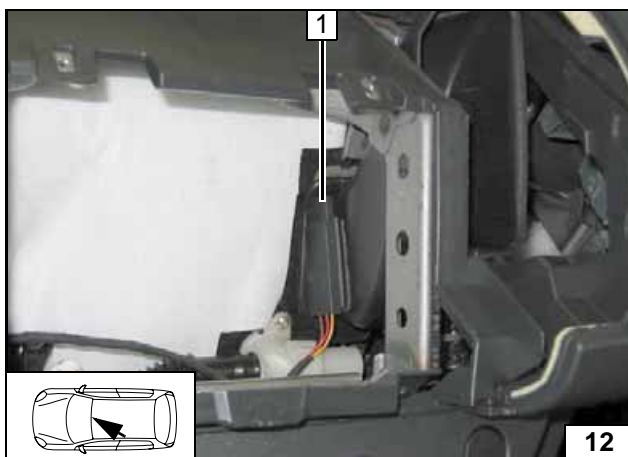

**Temperature sensor for HTM100 only**

- 1 Temperature sensor, fasten behind glove compartment with suitable means



**Installing temperature sensor**

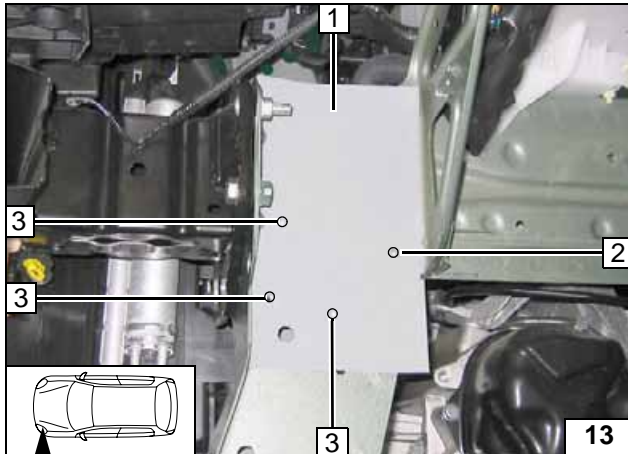
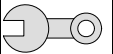

**Preparing installation location**

- 1 Template
- 2 Copy hole pattern, 7 mm dia. hole
- 3 Copy hole pattern, drill 9.1 mm hole [3x]

Copying hole pattern

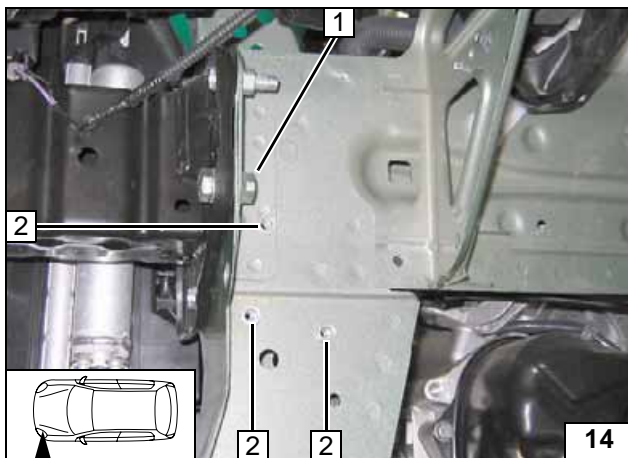

- 1 Shorten original vehicle bolt flush with nut
- 2 M6 rivet nut [3x]

Installing rivet nut

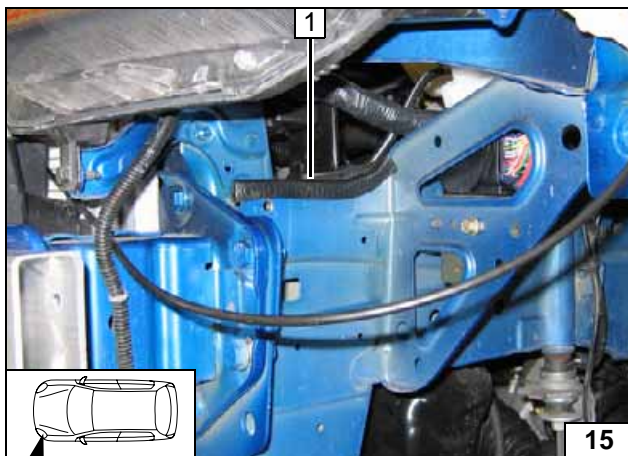

- 1 Edge protection

Preparing installation location

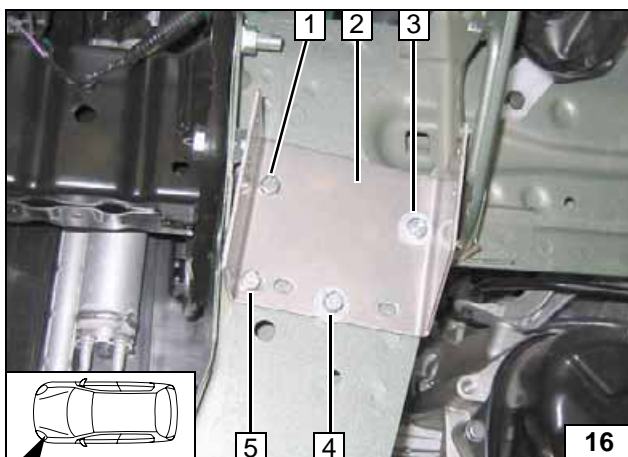

Insert one 5 mm spacer each between 2 and body at position 3, 4 and 5.

- 1 M6x20 bolt, spring lockwasher, large diameter washer
- 3 M6x20 bolt inserted from behind, large diameter washer, M6 flanged nut
- 4 M6x25 bolt, spring lockwasher, large diameter washer
- 5 M6x25 bolt, spring lockwasher, washer [2x]



Installing bracket

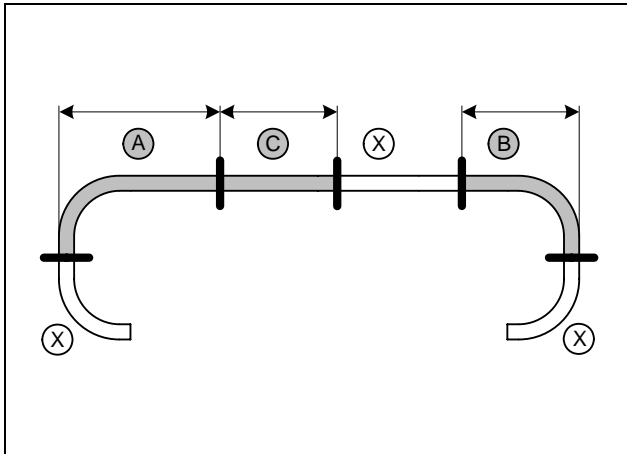
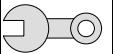

**Preparing heater unit**

**1,6L**

a = 770  
b = 120  
c = 670

Discard section X

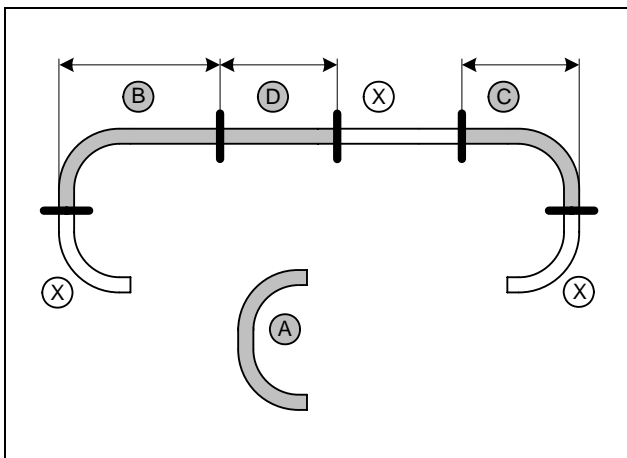

**1,8L**

b = 820  
c = 120  
d = 670

Hose A = 180° elbow  
Discard section X

Cutting coolant hoses to length

Cutting coolant hoses to length

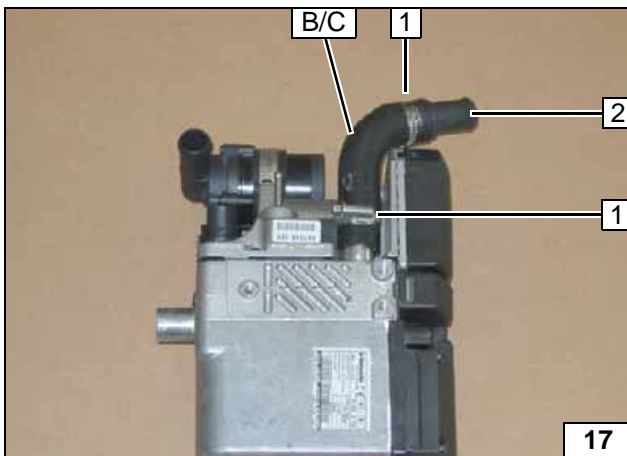

Hose B on 1.6 liter engine.  
Hose C on 1.8 liter engine.

- 1 27 mm dia. clamp [2x]
- 2 20x20 connecting pipe



Premounting coolant hose

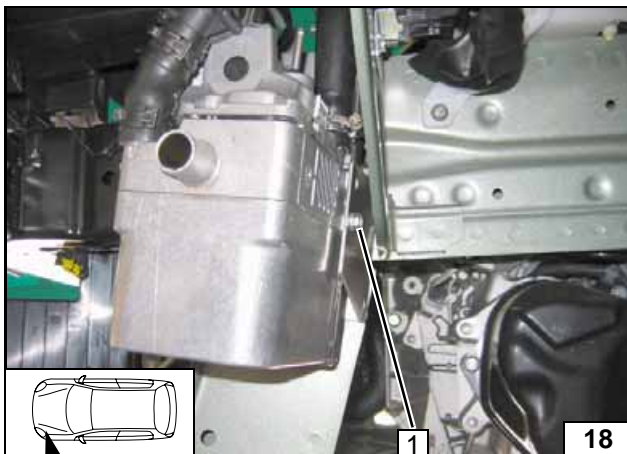

**Installing heater unit**

- 1 Eject screw

Installing heater unit

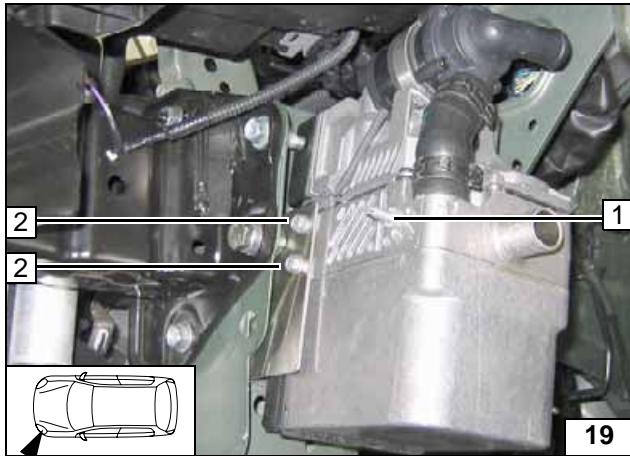
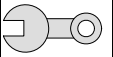

- 1 E-jot stud
- 2 E-jot screw [2x]

Installing  
heater unit

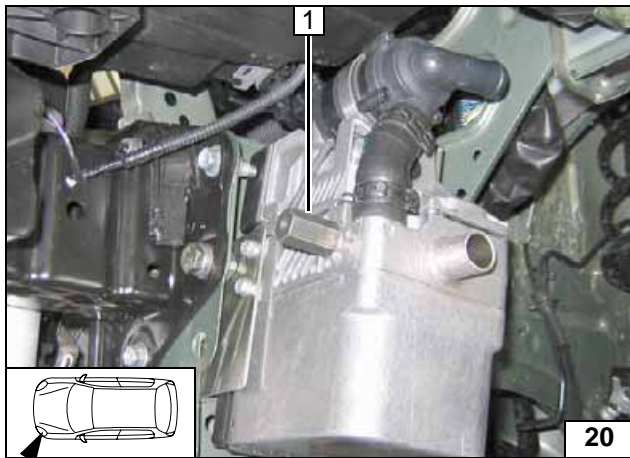

- 1 M6x30 spacer nut

Installing  
heater unit

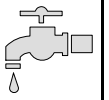

**Coolant, 1.6 liter engine**

**WARNING!**

Any coolant running off should be collected using an appropriate container. Install hoses so that they are kink-free. Unless specified otherwise, always fasten using cable ties. Position clamps so that no other hose can be damaged! When installing the coolant hose, the heater unit must be filled with coolant.

The connection should be "inline" based on the following diagram:

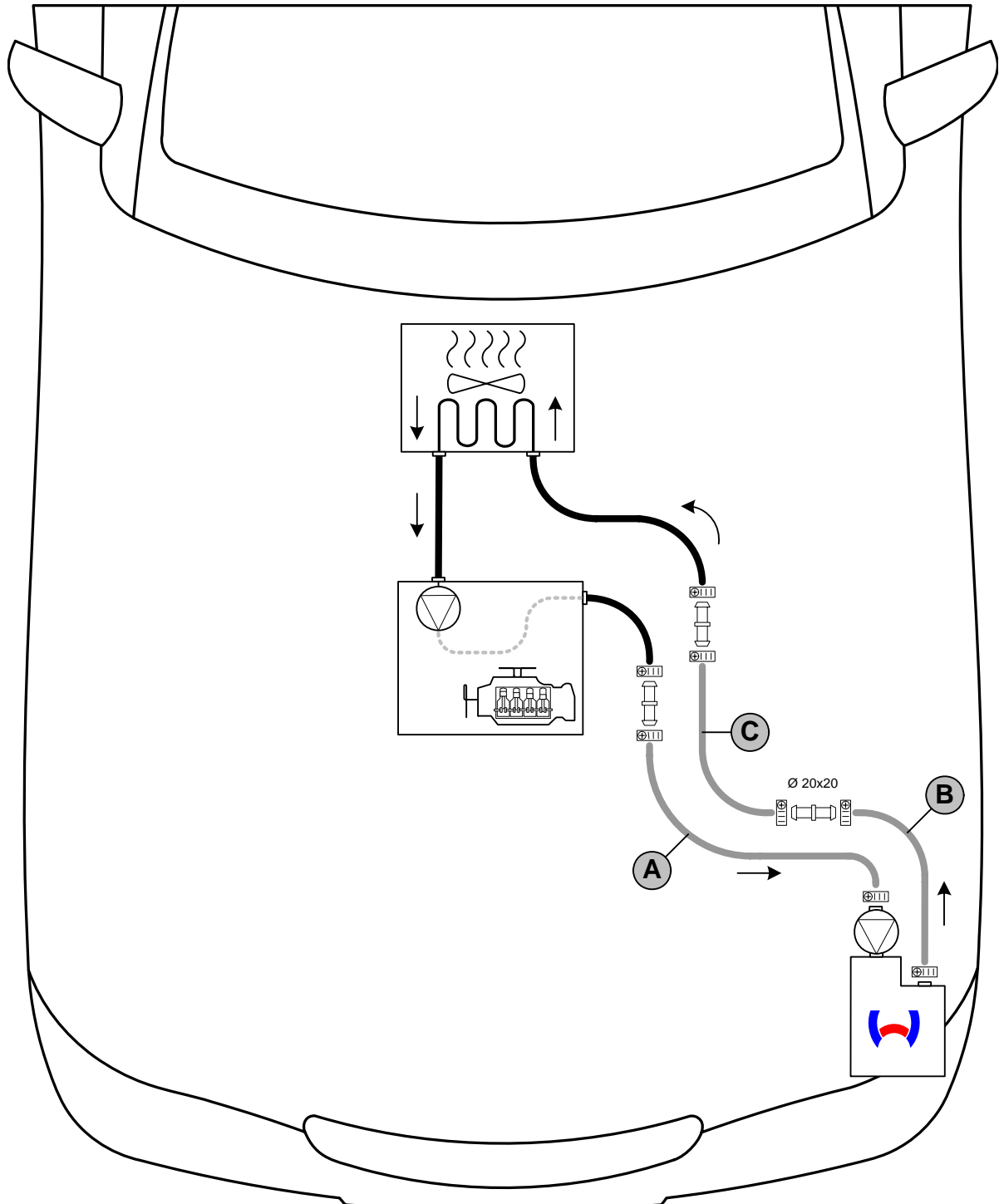

Coolant routing diagram

All connecting pipes without a specific designation (□□) = dia. 18x20. All hose clamps (⊕□□) = 20-27 mm dia.!



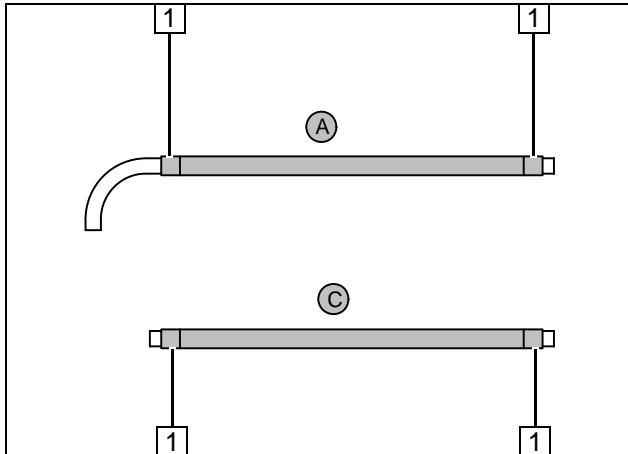

Push braided protection hoses onto hose **A** and **C** and cut to length.  
Cut heat shrink plastic tubing to length.

1 25 mm long heat shrink plastic tubing [4x]

Preparing coolant hoses

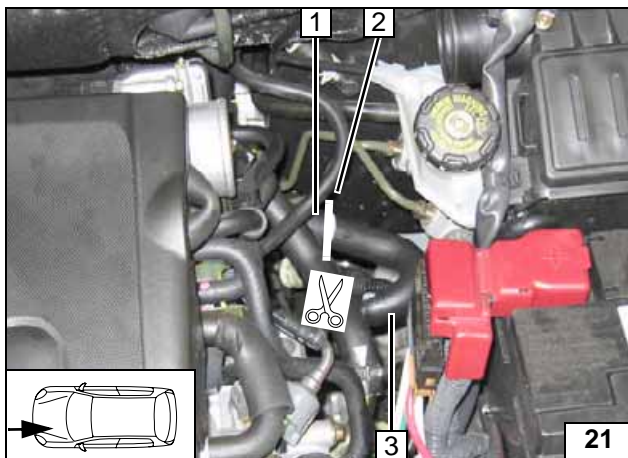

1 Hose section of heat exchanger inlet  
2 Cutting point  
3 Engine outlet hose section

Cutting point

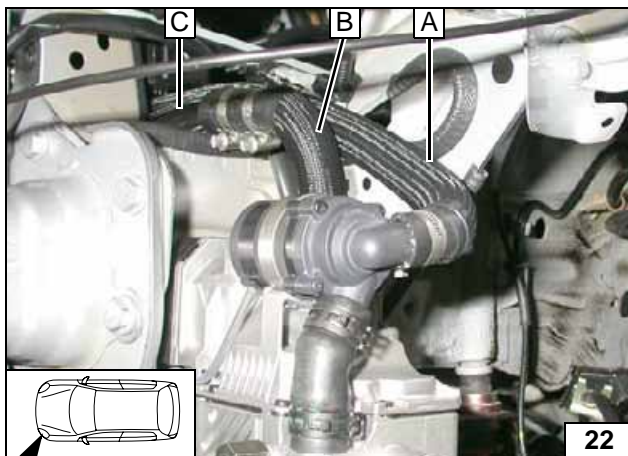

Connecting heater unit



Routing in engine compartment

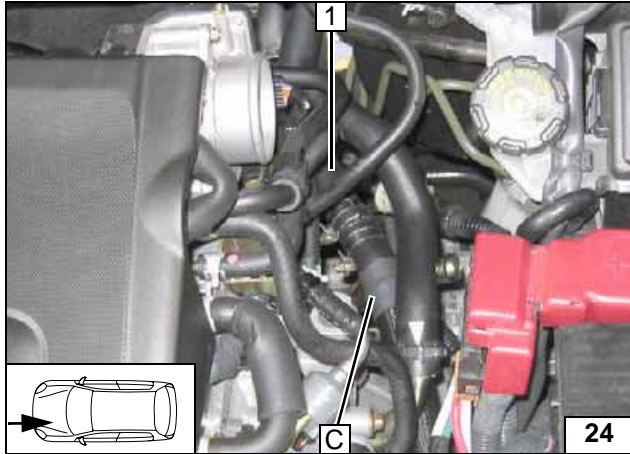

Ensure sufficient distance to neighboring components.

1 Hose on heat exchanger inlet



Connect-  
ing heat  
exchanger  
inlet

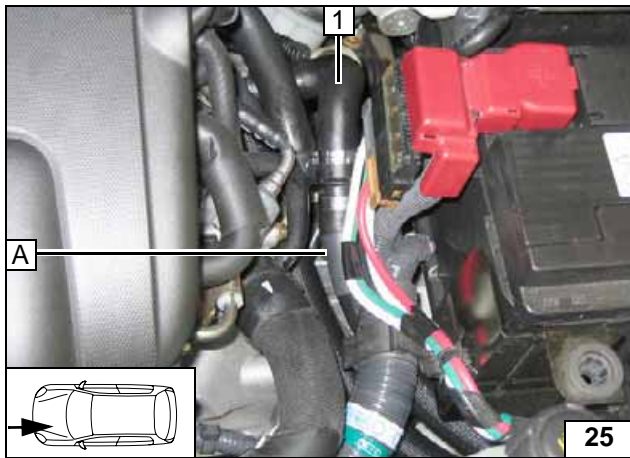

1 Hose on engine outlet turned

Connect-  
ing engine  
outlet



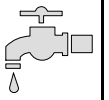

**Coolant, 1.8 liter engine**

**WARNING!**

Any coolant running off should be collected using an appropriate container. Install hoses so that they are kink-free. Unless specified otherwise, always fasten using cable ties. Position clamps so that no other hose can be damaged! When installing the coolant hose, the heater unit must be filled with coolant.

The connection should be "inline" based on the following diagram:

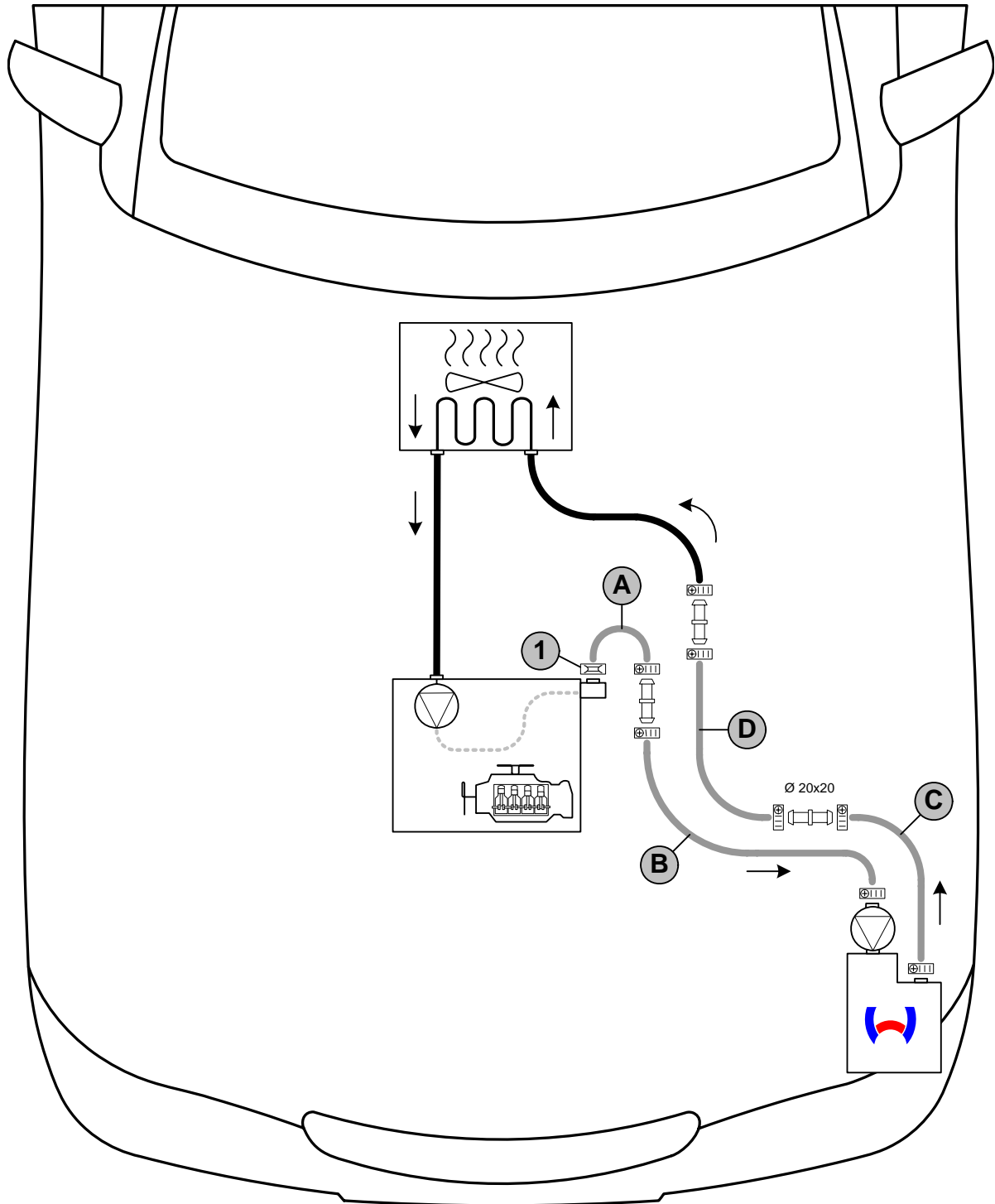

**Coolant routing diagram**

1 = Original vehicle spring clip . All hose clamps = 20-27 mm dia.!  
All connecting pipes without a specific designation = dia. 18x20.



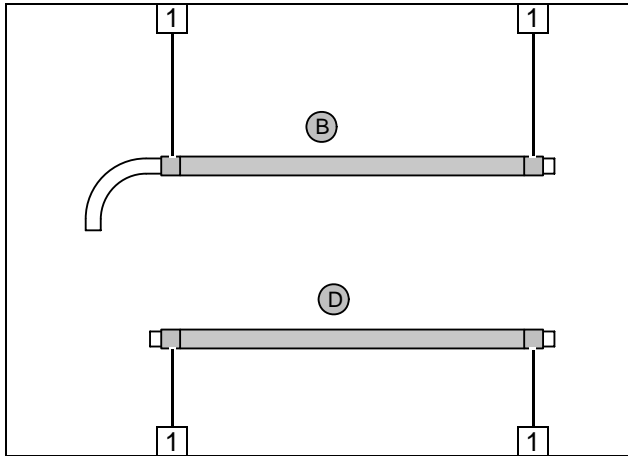

Push braided protection hoses onto hose **B** and **D** and cut to length.  
Cut heat shrink plastic tubing to length.

1 25 mm long heat shrink plastic tubing [4x]



Preparing coolant hoses

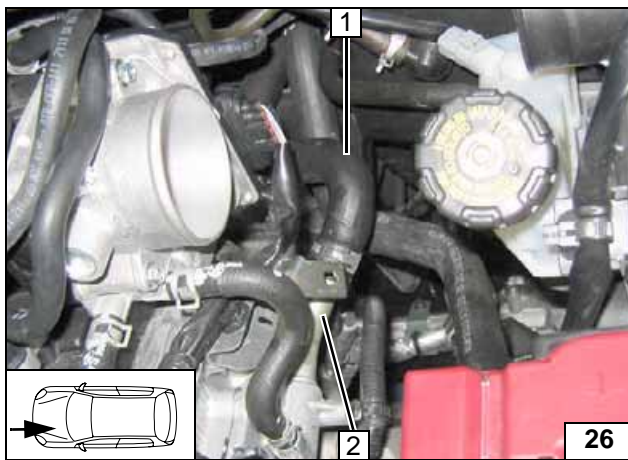

Disconnect hose to heat exchanger inlet **1** from connection piece of engine outlet **2**. Original vehicle clamp will be reused.



Cutting point

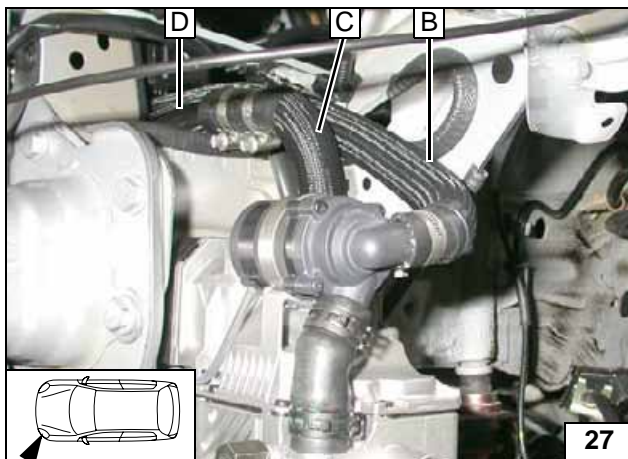

Connect-  
ing heater  
unit

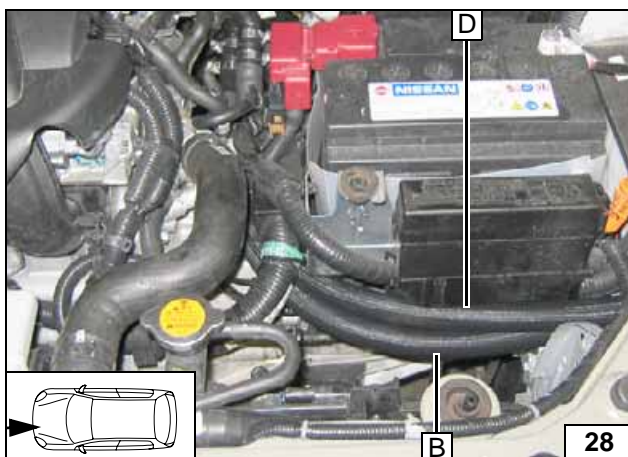

Routing in  
engine  
compartment

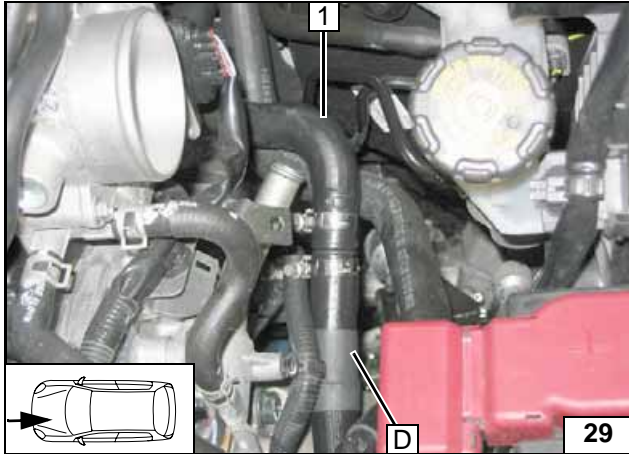
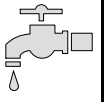

Ensure sufficient distance to neighboring components.

1 Hose on heat exchanger inlet



Connect-  
ing heat  
exchanger  
inlet

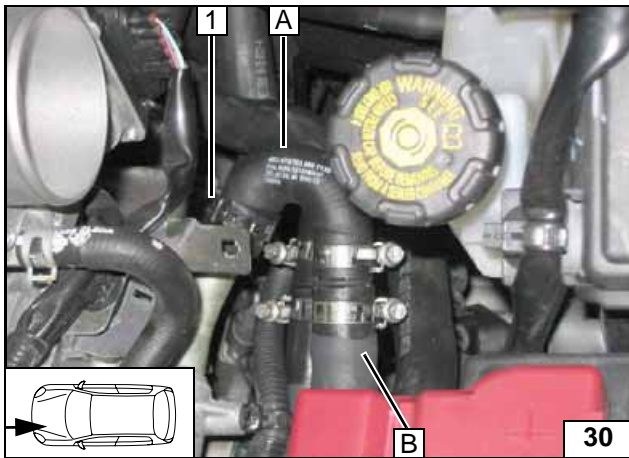

1 Original vehicle clamp



Connect-  
ing engine  
outlet

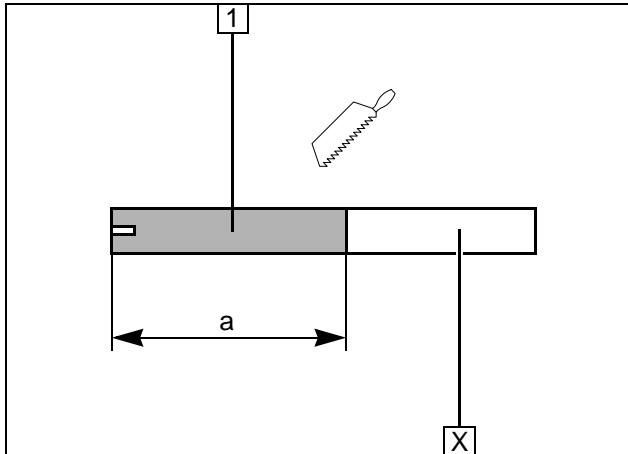
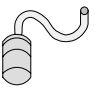

**Combustion air**

**1** Combustion air pipe  
a = 210

Discard section **X**

**Cutting combustion air pipe to length**

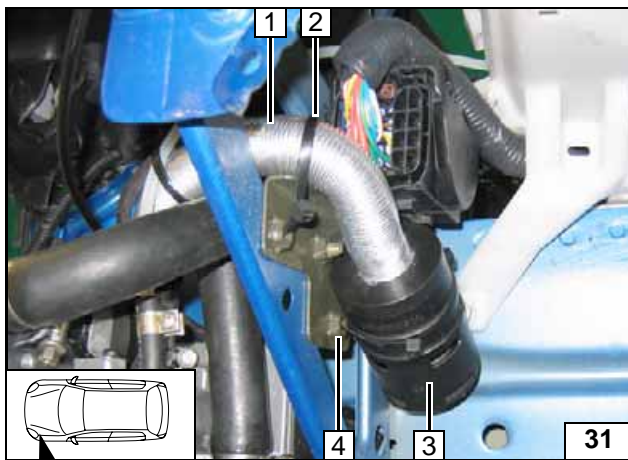

Fasten combustion air pipe **1** on heater unit with 20-27 mm dia. clamp. Fasten muffler **3** at original vehicle hole with cable tie **4**.

**2** Cable tie



**Installing muffler**

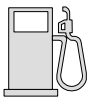

**Fuel**

**CAUTION!**

Open the vehicle's fuel tank cap, ventilate the tank and then re-close the tank lock.

Catch any fuel running off with an appropriate container.

Install fuel line and metering-pump wiring harness so that they are protected against stone impact. Unless specified otherwise, always fasten using cable ties.

Mount the fuel line and wiring harness with rub protection on sharp edges.

**WARNING!**

The fuel line and wiring harness are routed to the metering pump in as shown in the wiring harness routing diagram.

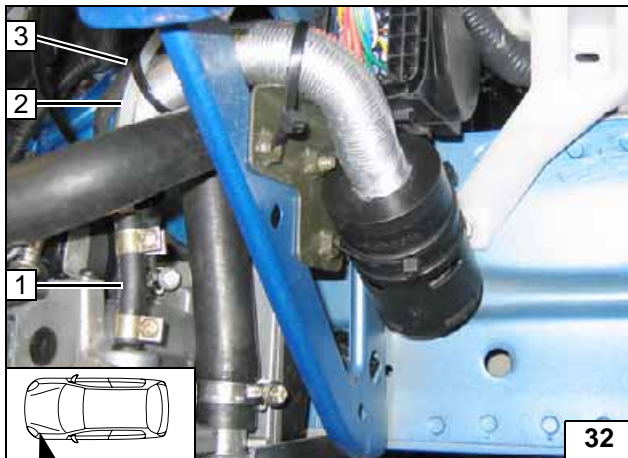

- 1 Hose section, 10 mm dia. clamp [2x]
- 2 Fuel line
- 3 Cable tie

Connect-  
ing heater  
unit

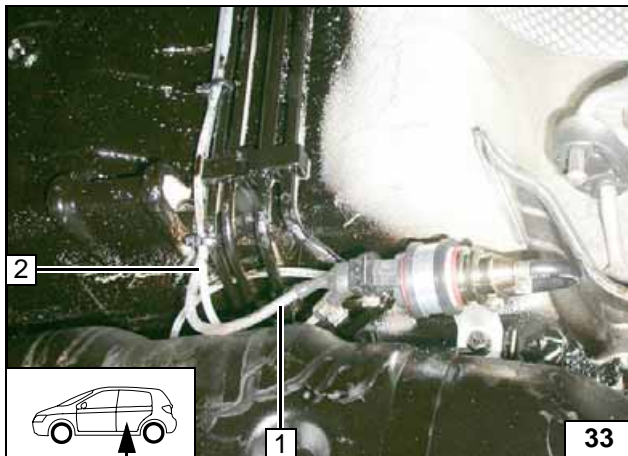

Route fuel line 2 together with wiring harness of metering pump 1 to installation location of metering pump.



Installa-  
tion loca-  
tion of  
metering  
pump

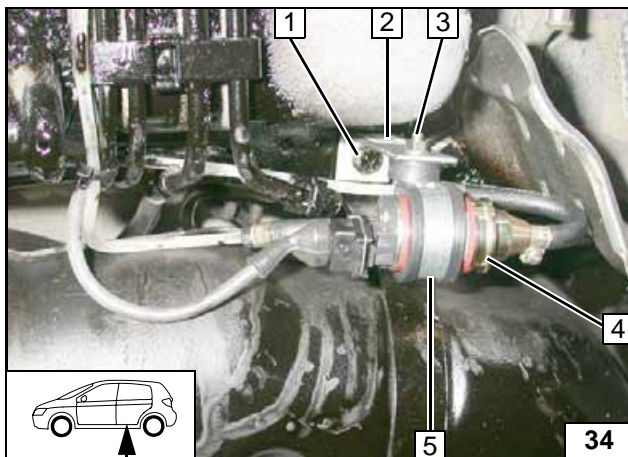

- 1 Original vehicle bolt
- 2 Angle bracket
- 3 Silent block, flanged nut [2x]
- 4 Metering pump
- 5 Rubber-coated pipe clamp



Installing  
metering  
pump

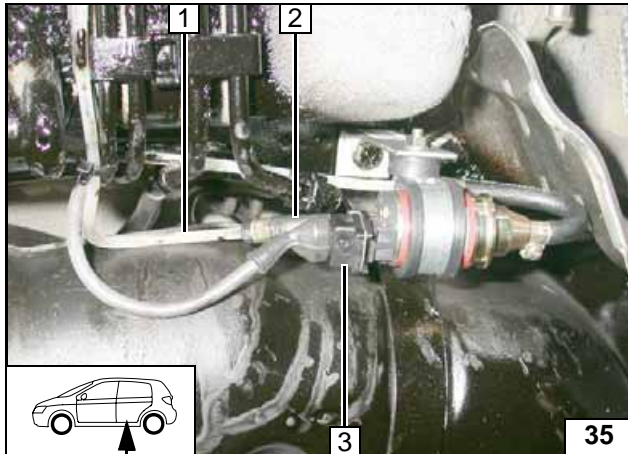

Check the position of the components; adjust if necessary. Check that they have free clearance.

- 1 Fuel line
- 2 Hose section, 10 mm dia. clamp [2x]
- 3 Wiring harness of metering pump, connector mounted



**Connecting metering pump**

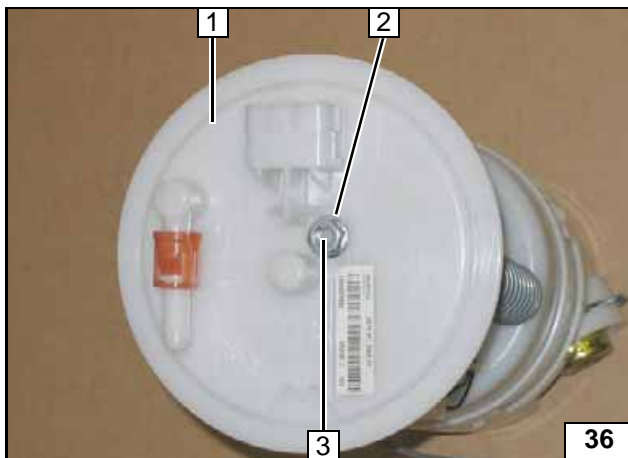

Remove fuel-tank sending unit 1 according to manufacturer's specifications.

- 2 Position flanged nut
- 3 Copy hole pattern, 6 mm dia. hole



**Removing fuel**

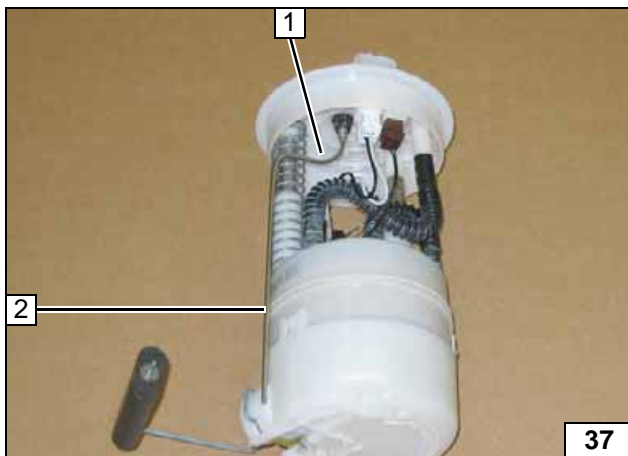

Shape fuel standpipe 1 according to template, cut to length and install.



**Installing fuel standpipe**

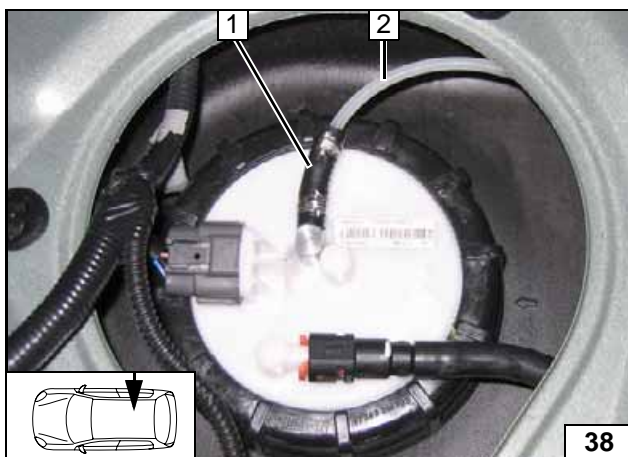

Install fuel-tank sending unit according to manufacturer's specifications.

- 1 Hose section, 10 mm dia. clamp [2x]
- 2 Fuel line



**Connecting fuel line**

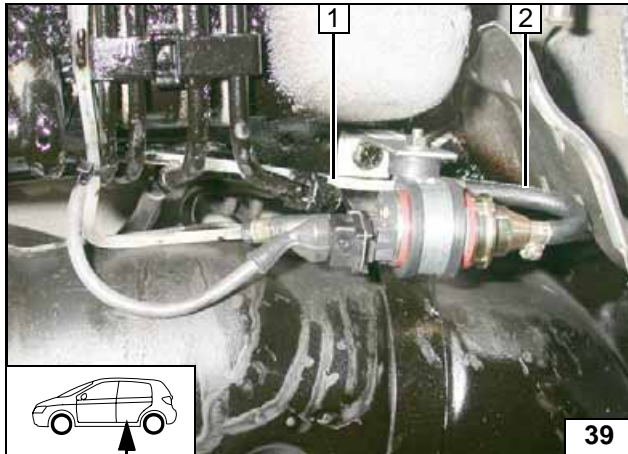

Check the position of the components; adjust if necessary. Check that they have free clearance.

- 1 Fuel line
- 2 Molded hose, 10 mm dia. clamp [2x]



**Connect-  
ing meter-  
ing pump**

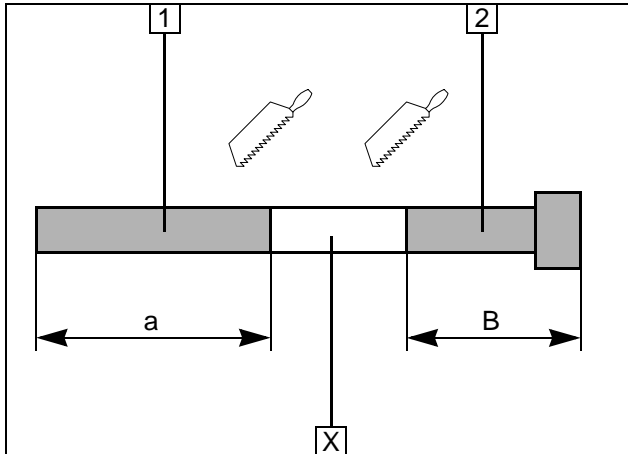
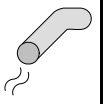

**Exhaust gas**

- 1 Exhaust pipe  
a = 280
- 2 Exhaust end section  
b = 320

Discard section X

**Preparing exhaust pipe**

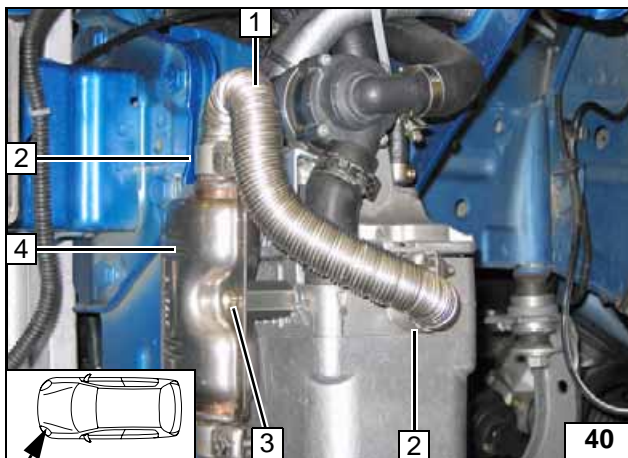

- 1 Exhaust pipe
- 2 Hose clamp [2x]
- 3 M6x12 bolt, spring lockwasher
- 4 Muffler

**Installing muffler**

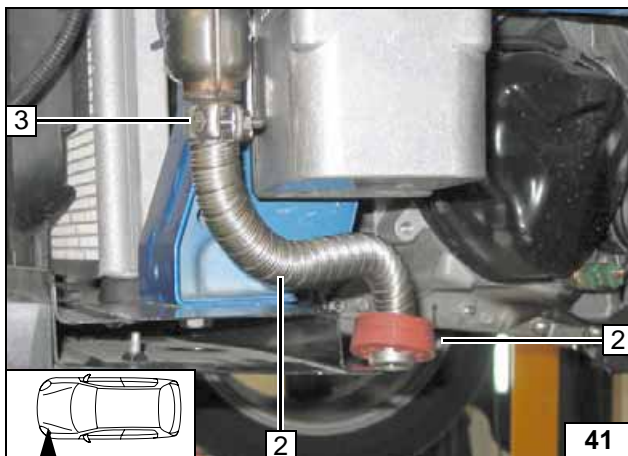

- 1 Red (rt) rubber isolator with groove
- 2 Exhaust end section
- 3 Hose clamp

**Installing end section**

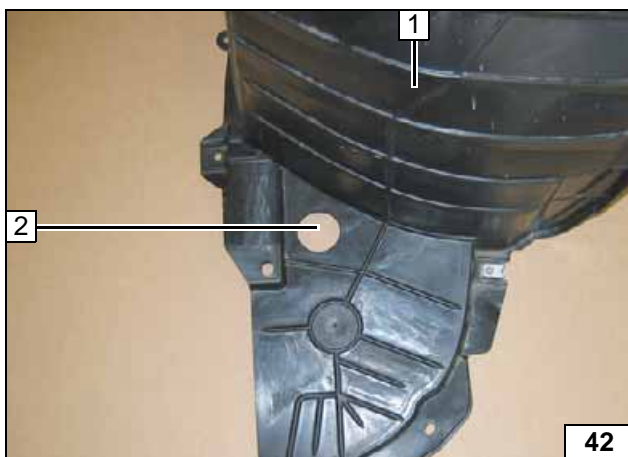

- 1 Wheel well trim
- 2 42 mm dia. hole

**Hole in wheel well trim**



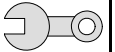

## Final Work

### WARNING!

Reassemble the disassembled components in reverse order.

Check all hoses, clamps and all electrical connections for firm seating.

Secure all loose cables using cable ties.

Only use manufacturer-approved coolant.

Spray the heater unit components with anti-corrosion wax (Tectyl 100K, Order No. 111329).

- Connect the battery
- Fill and bleed the coolant circuit according to the vehicle manufacturer's specifications.
- Set the digital timer.
- Make settings on A/C control panel according to the "Operating Instructions for End Customer".
- Check the proper operation of the additional heater, see the operating instructions/installation instructions.
- Attach the "Switch off additional heater before refueling" sticker to the left-hand B-pillar.

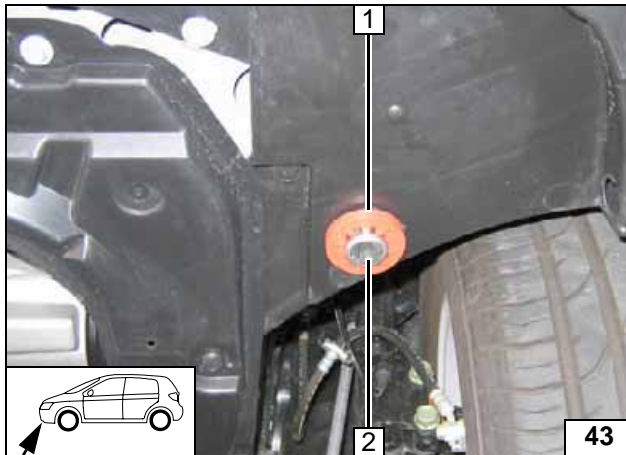

Align exhaust end section 2 flush on red rubber isolator 1.

**Mounting  
rubber iso-  
lator**

**Webasto**  
*Feel the drive*

Webasto AG  
Postfach 80 - 82132 Stockdorf  
Hotline 01805 / 932278 - Hotfax 0395 / 5592-353  
<http://www.webasto.de>

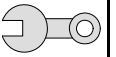

### Template for Fuel Standpipe

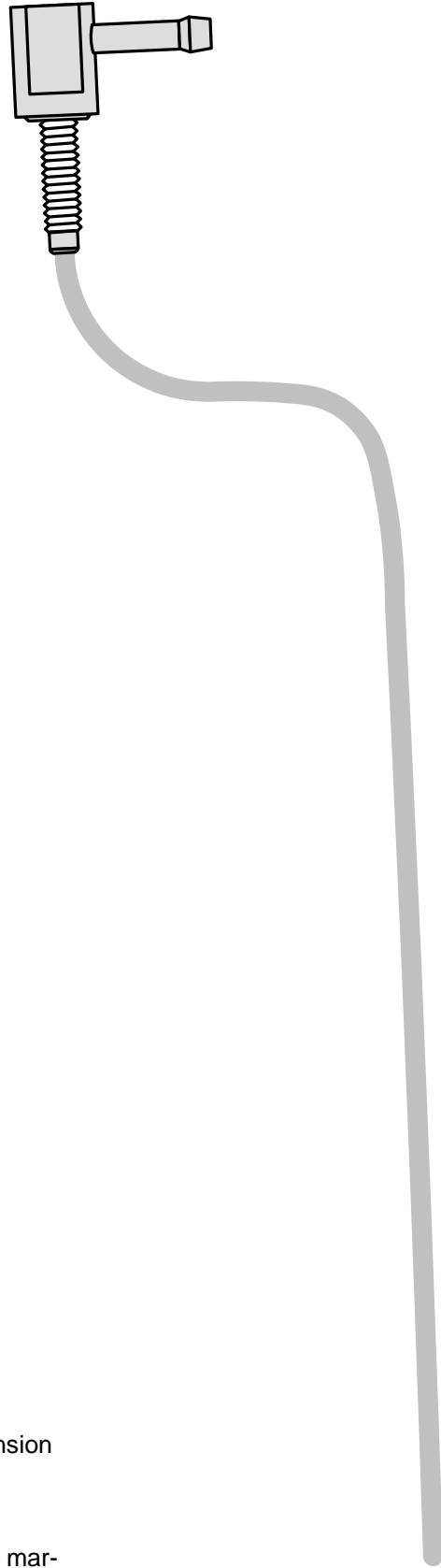

100 mm



Scale 1:1

Compare the size of the printed version with dimension lines.  
Permitted tolerance a maximum of 2%.

Set the printer settings to "no margin" or "minimize margins" and 100% of the normal size.

100 mm

0

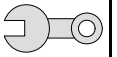

### Drilling Template

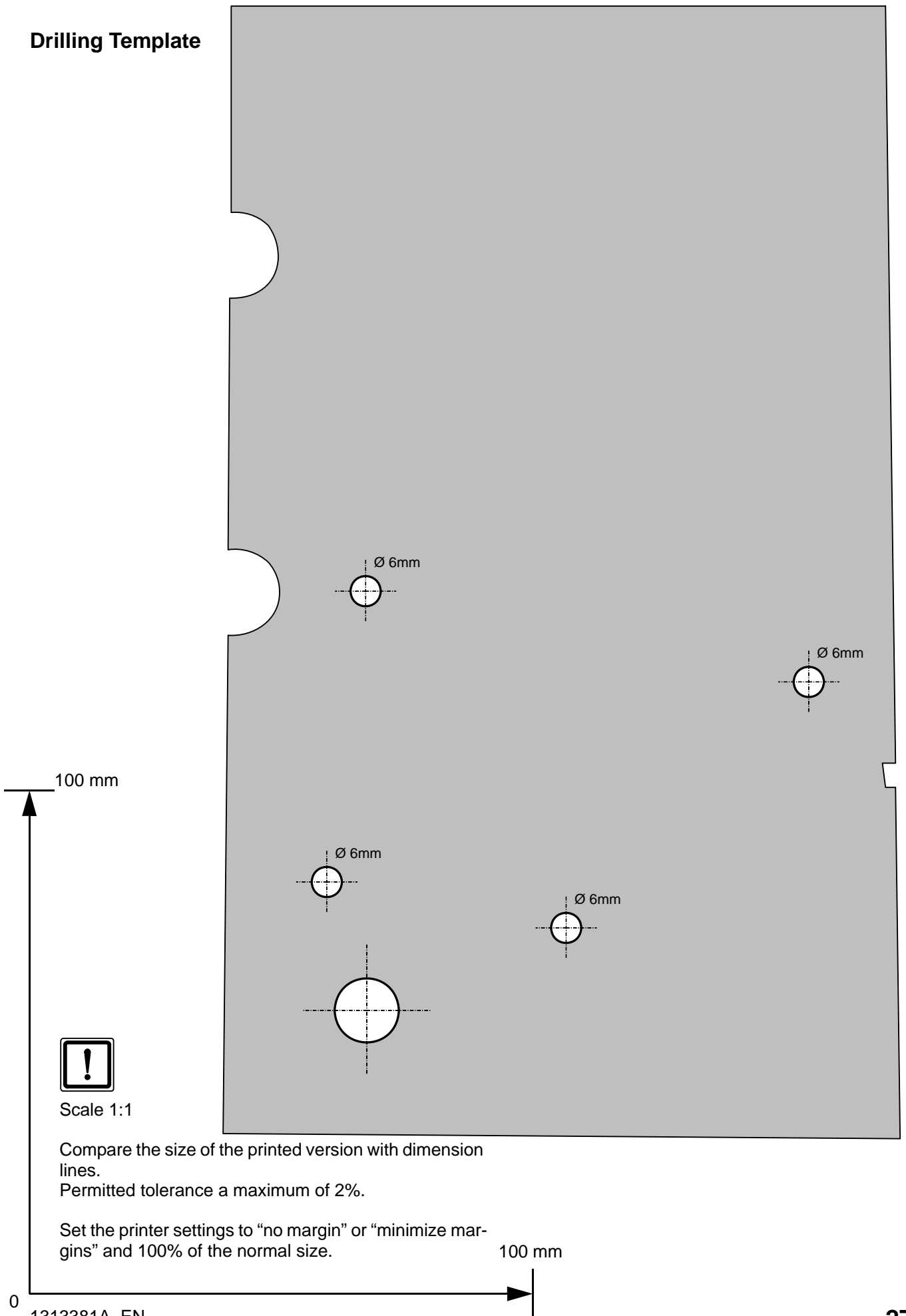

Scale 1:1

Compare the size of the printed version with dimension lines.  
Permitted tolerance a maximum of 2%.

Set the printer settings to "no margin" or "minimize margins" and 100% of the normal size.

**Operating Instructions for End Customer**



Please remove page and add to the vehicle operating instructions.

**Note:**

We recommend matching the heating time to the driving time.

Heating time = driving time

**Example:**

For a driving time of approx. 20 min. (in one direction), we recommend not exceeding a switch-on time of 20 min.

If the summer/winter switch option has been installed, this must be switched in accordance with the time of year. The heater unit will then only switch on the vehicle fan to ventilate the vehicle interior in the position Winter heat and in the position Summer .



Before parking the vehicle, make the following settings:



- 1 Air outlet to windshield
- 2 Set temperature to "max."
- 3 Set fan to level "1", or possibly "2"

**Manual air conditioning**



- 1 Air outlet to windshield
- 2 Set fan to level "1", or possibly "2"
- 3 Set temperature to "max."

**Automatic air-conditioning**