

Air Heater Unit



Air Top 2000 ST Air Heater



Installation Instructions

Opel Vivaro

Diesel
from Model Year 2001
Left-hand drive vehicle
not with ESP

Passenger single seat



WARNING!

Hazard warning:

Incorrect installation or repair of Webasto heating systems may cause a fire or result in the emission of carbon monoxide, which can be fatal. Serious or fatal injuries can be caused as a result.

Specialist company training, technical documentation, specialized tools and equipment are required to install and repair Webasto heating and cooling systems.

NEVER attempt to install or repair Webasto heating or cooling systems if you have not successfully completed the company training and thereby acquired the required technical skills, or if you do not have access to the required technical documentation, tools and equipment needed to carry out correct installation and repairs.

ALWAYS follow all Webasto installation and repair instructions and observe all warnings.

Webasto does not accept any liability for defects and damage that are attributable to installation by untrained staff.

Table of Contents

Validity	2	Heater unit without air ducting	14
Heater Unit/Installation Kit	3	Heater unit with air ducting	14
Foreword	3	Electrical Connections	15
General Instructions	3	Temperature sensor option	16
Special Tools	3	Routing wiring harnesses	16
Explanatory Notes on Document	4	Connection of combination timer up to 2006 model	17
Preliminary Work	5	Connection of combination timer from 2007 model	17
Heater unit installation location	5	Remote option (Telestart)	18
Preparing installation location	6	Connection to battery	19
Preassembling heater unit	7	Connection Diagram for Combination Timer	20
Installing heater unit	7	Connection Diagram for Combination Timer and Telestart	21
Combustion air	8	Operating Instructions for End Customer	22
Fuel Connection	9	Drilling Template	23
Exhaust system	11		

Validity

Manufacturer	Model	Type	EG-BE No./ABE
Opel	Vivaro	X83	e1 *98 / 14 * 0170 ...
		F7	K830
		E7	L048

Engine type	Engine model	Output in kW	Displacement in cm ³
F9Q	Diesel	60	1870
F9Q	Diesel	74	1870
M9R	Diesel	66	1995
M9R	Diesel	84	1995
G9U	Diesel	99	2464
G9U	Diesel	107	2464

Vehicle and engine types, equipment variants and national specifications not listed in these installation instructions have not been tested. However, installation according to these installation instructions may be possible.

The installation location of a digital timer and summer/winter switch should be confirmed with the end customer before installation.

Heater Unit/Installation Kit

Quantity	Description	Order No.:
1	Opel-specific delivery scope of AT 2000 ST 12V D	1311064A

Quantity	Description	Order No.:
1	Installation kit for Air Top 2000 ST with Combination Timer	1312245A

To be ordered as an option for vehicles with partition wall:

Quantity	Description	Order No.:
1	Putty for air ducting	1312246A

To be ordered as an option when using Telestart:

Note: Telestart only possible in conjunction with combination timer

Quantity	Description	Order No.:
1	Telestart	See price list
1	Y-cable for Telestart/combination timer	1311677A
1	Extension cable (only when using Telestart T100 HTM)	1311816A

Foreword

These installation instructions apply to Opel Vivaro Diesel vehicles - for validity, see page 2 - from model year 2001 and later, assuming technical modifications to the vehicle do not affect installation, any liability claims excluded. Depending on the vehicle version and equipment, modifications may be necessary during installation with respect to these installation instructions.

However, where this is the case the stipulations in the "installation instructions" and "operating and maintenance instructions" for the *Air Top 2000 ST* should be observed.

The corresponding rules of technology and any information from the vehicle manufacturer should be observed during the installation work.

General Instructions

Installation should be carried out according to the general, standard rules of technology. Unless specified otherwise, fasten hoses, lines and wiring harnesses to original vehicle lines and wiring harnesses using cable ties.

Sharp edges should be fitted with edge protectors (split-open plastic hose).

Spray unfinished body areas, e.g. drilled holes, with anti-corrosion wax (Tectyl 100K, Order No. 111329).

Special Tools

- Torque wrench for 2.0 - 10 Nm
- Hole saw, 60 mm dia.
- Stepped drill bit, 26 mm dia.
- Metric thread-setter kit
- Blind rivet tool

Explanatory Notes on Document

To provide you with a quick overview of the individual working steps, you will find an identification mark on the outside top right corner of the page in question.

Mechanical system

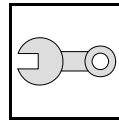

Electrical system

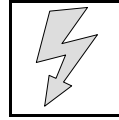

Heating air

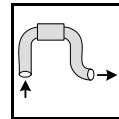

Fuel

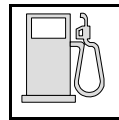

Exhaust gas

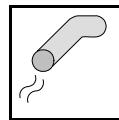

Combustion air

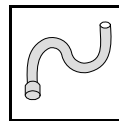

Special features are highlighted using the following symbols:



Specific risk of injury or fatal accidents.



Specific risk of damage to components.



Specific risk of fire or explosion.



Reference to general installation instructions of Webasto components or to the manufacturer's vehicle-specific documents.



Reference to a special technical feature.



The arrow in the vehicle icon indicates the position on the vehicle and the viewing angle.

All dimensions are in mm!

Tightening torque of hose clamps = 2.0 + 0.5 Nm!

Preliminary Work

WARNING!

- Open the fuel tank cap, ventilate the tank.
- Close the tank cap again.
- Remove the service door of the battery compartment
- Copy the factory number from the original type label to the duplicate type label.
- Remove years that do not apply from the duplicate label.
- Attach the duplicate label (type label) in the appropriate place.
- Remove the front passenger seat
- Remove the driver's seat
- Remove the left and right-hand door sill trim
- Remove the left-hand A-pillar trim window pillar (when using combination timer or Telestart)
- Remove the interior light (when using combination timer or Telestart)



Heater unit installation location

- 1 Heater unit

Installation
location

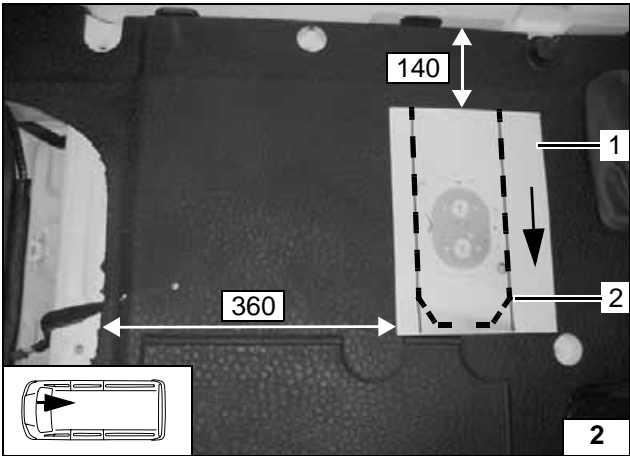
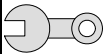

Preparing installation location

- 1 Template
- 2 Copy cutting edge to insulating mat

Preparing installation location

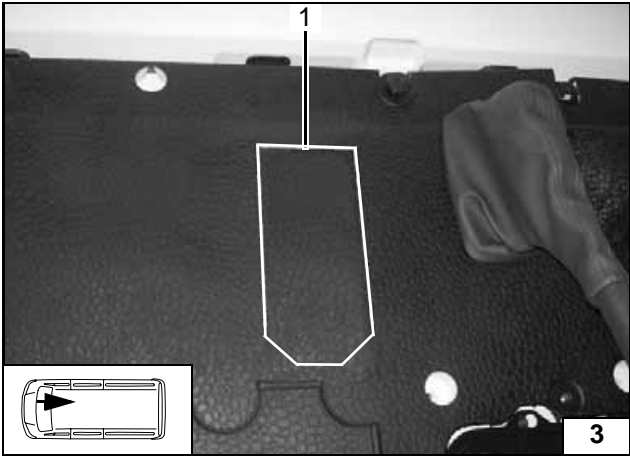

- 1 Cut out within marking

Preparing installation location

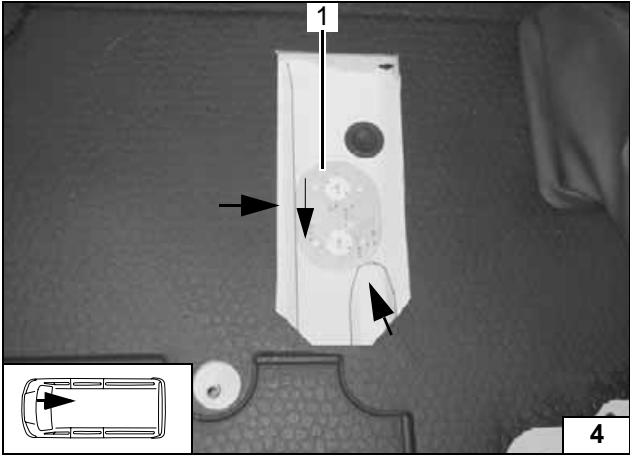

Cut out template 1 , lay on beads of underbody. Observe direction of arrow. Copy hole patterns.



Preparing installation location

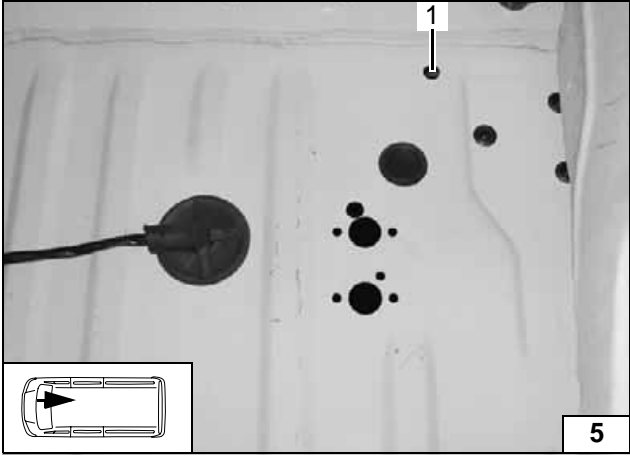

Drill holes according to template.

- 1 Push through cable grommet



Preparing installation location

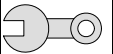

Preassembling heater unit

- 1 Heater unit
- 2 Spacer plate
- 3 Base seal

Preassembling heater unit



Installing heater unit

Route wiring harness of digital timer under floor mat to left-hand A-pillar. Detach fuse holder from wiring harness of power supply and route downward through grommet. Route through wire of metering pump downward.

- 1 Protective grill



Installing heater unit

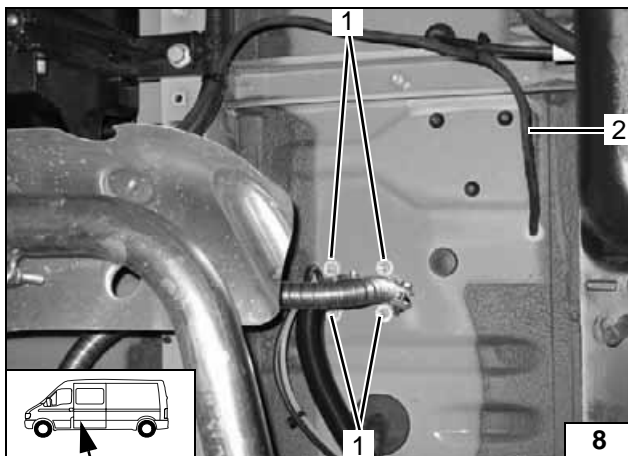

Route wiring harness of power supply 2 to battery box

- 1 Washer, M6 nut [4x each]



Installing heater unit

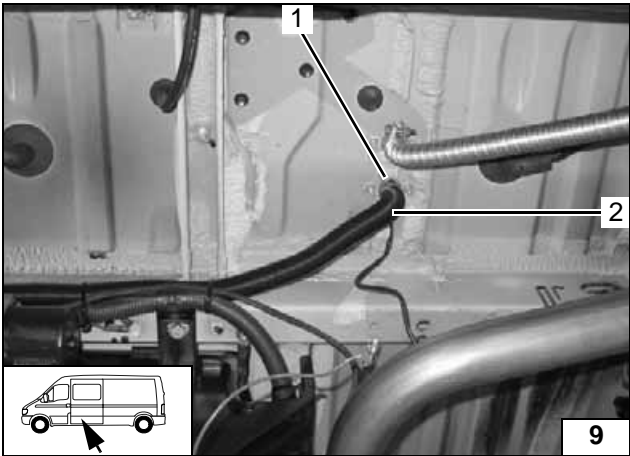

Combustion air

Ensure proper installation position of air intake line, see "Installation Instructions"

- 1 Hose clamp
- 2 Combustion-air intake pipe



Installing combustion-air intake muffler

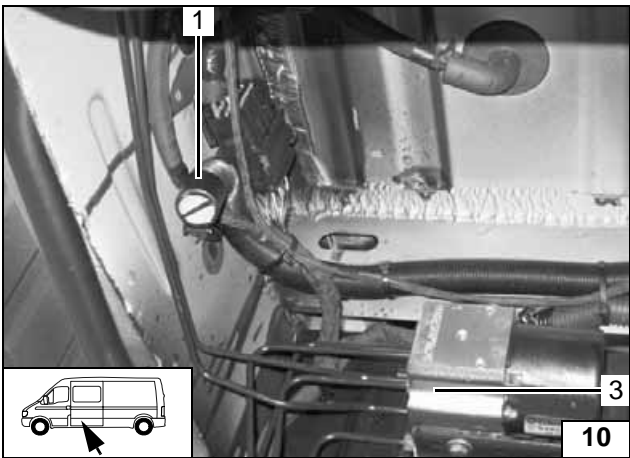

- 1 End cap

Installing combustion-air intake muffler



Fuel Connection

CAUTION!

Open the vehicle's fuel tank cap, ventilate the tank and then re-close the tank lock.

Catch any fuel running off with an appropriate container.

Install fuel line and metering-pump wiring harness so that they are protected against stone impact. Unless specified otherwise, always fasten using cable ties. Mount the fuel line and wiring harness with rub protection on sharp edges.

WARNING!

The fuel line and wiring harness are routed to the metering pump in as shown in the wiring harness routing diagram.

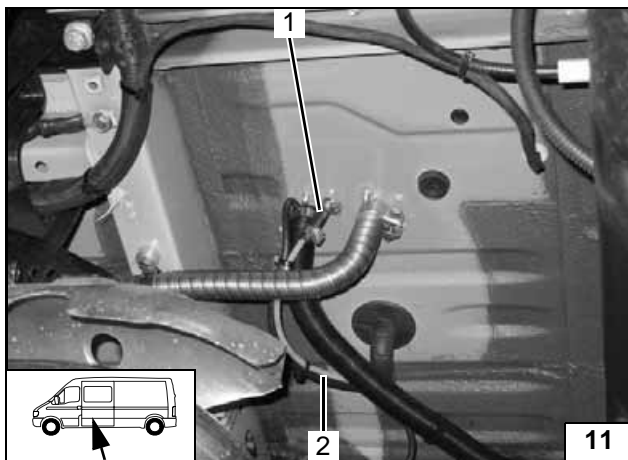

- 1 Hose section, 10 mm dia. hose clamps [2x]
- 2 Fuel line

Con-
nection to
heater unit

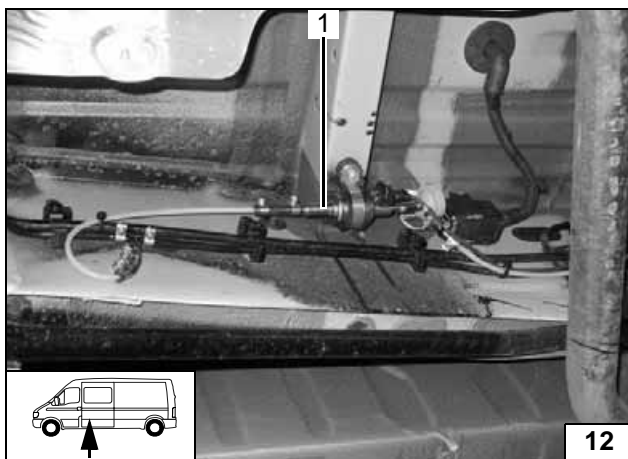

Ensure proper installation position of metering pump, see "Installation Instructions".
Installation location of cross member for underbody on right.
Fuel line from heater unit on pressure side of metering pump [side with connector].



Installation
location of
metering
pump

- 1 Metering pump

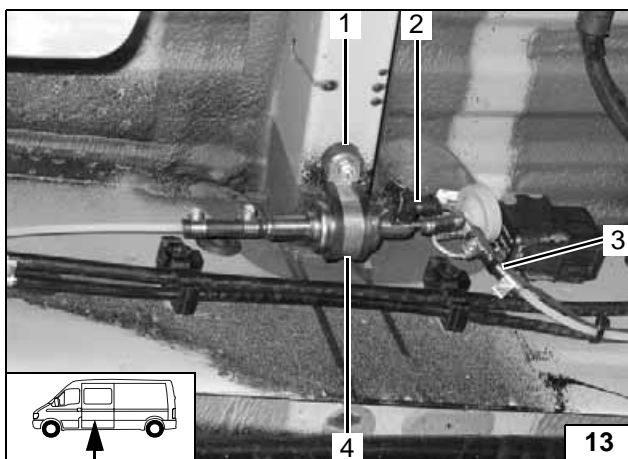

- 1 Existing thread or M6 rivet nut, silent block, flanged nut
- 2 Wiring harness of metering pump with connector housing
- 3 Hose section, 10 mm dia. hose clamps [2x]
- 4 Rubber-coated pipe clamp

Installing
metering
pump

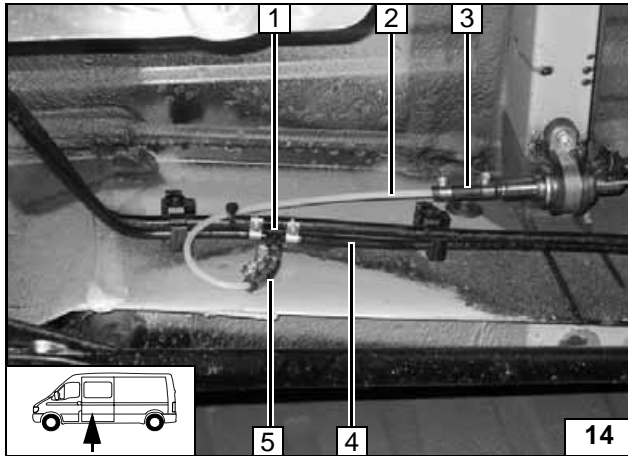

Disconnect fuel return line 4.

- 1 Fuel standpipe, 8 mm dia. hose clamp [2x]
- 2 Fuel line
- 3 Hose section, 10 mm dia. hose clamp [2x]
- 5 Hose section, 10 mm dia. hose clamp [2x]



**Removing
fuel**

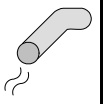

Exhaust system

WARNING!

The exhaust system can be assembled in 2 different versions. The version is dependent on the equipment and use of the vehicle!

Before installation, the version must be coordinated with the end customer!

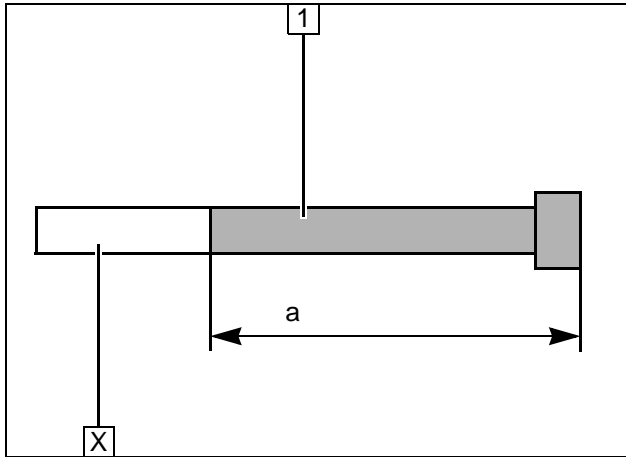

Right-hand exhaust outlet

- 1 Exhaust pipe
a = 700

Discard section X.

Cutting exhaust pipe to length

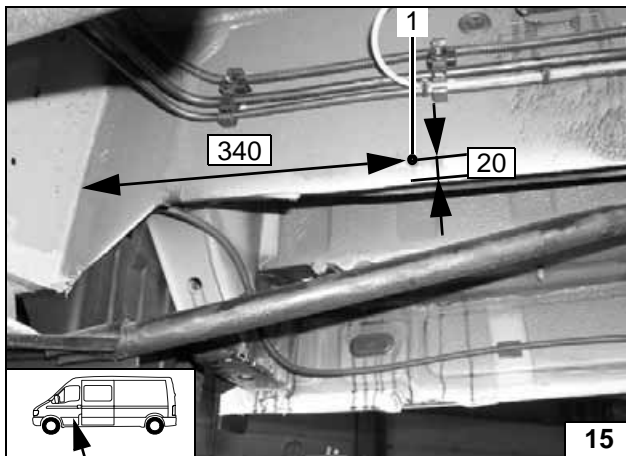

- 1 6.5 mm dia. hole

Drilling hole in cross member

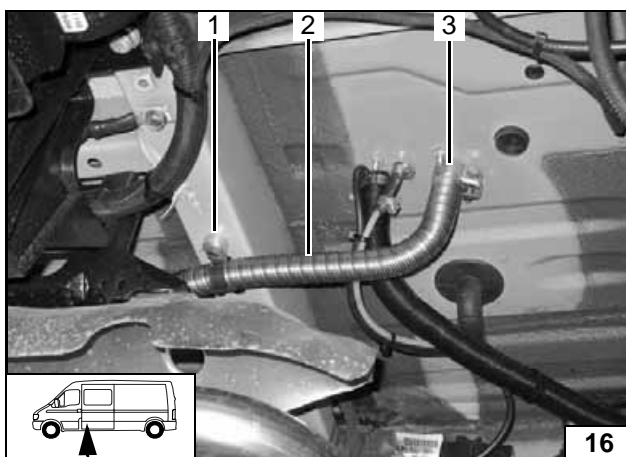

- 1 M6 rivet nut, M6x30 bolt, spring lockwasher, clamp, shim 10
- 2 Exhaust pipe
- 3 Hose clamp

Installing exhaust pipe

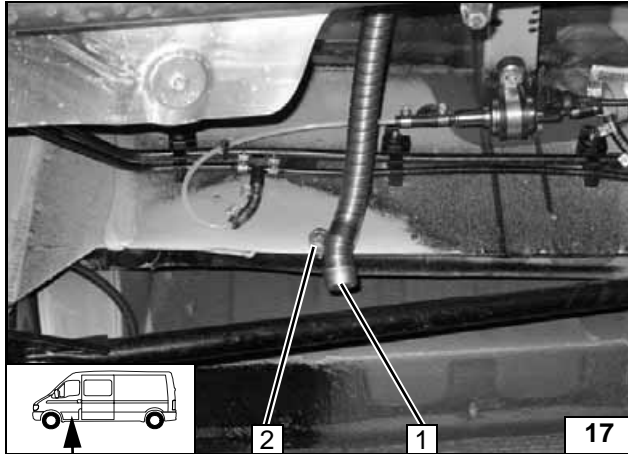
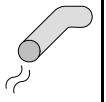

- 1 Exhaust end section
- 2 M6x30 bolt, spring lockwasher, clamp, shim 10, flanged nut

Installing exhaust pipe and end section

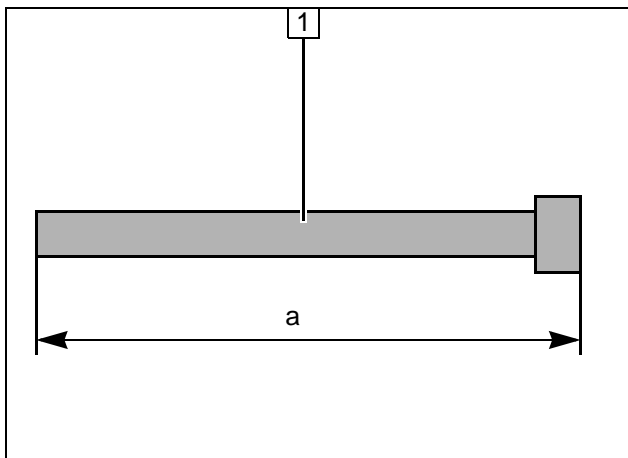

Left-hand exhaust outlet

- 1 Exhaust pipe
a = 1200

Exhaust pipe

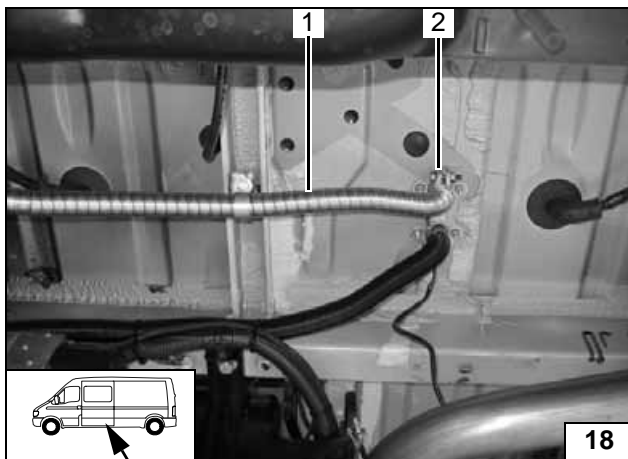

- 1 Exhaust pipe
- 2 Hose clamp

Installing exhaust pipe

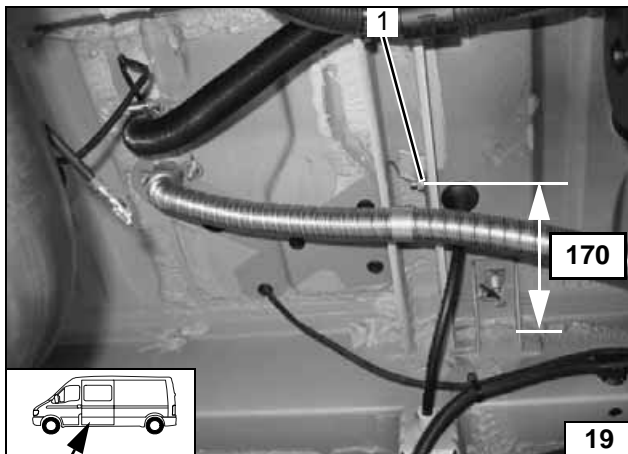

- 1 7 mm dia. hole

Installing exhaust pipe

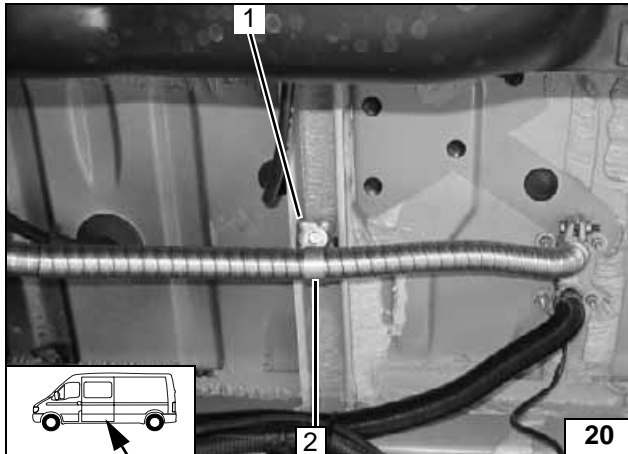
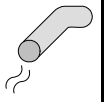

- 1 Angle bracket, M6x20 bolt, 7 mm dia. hole, large diameter washer, flanged nut
- 2 M6x20 bolt, clamp, flanged nut

Installing exhaust pipe

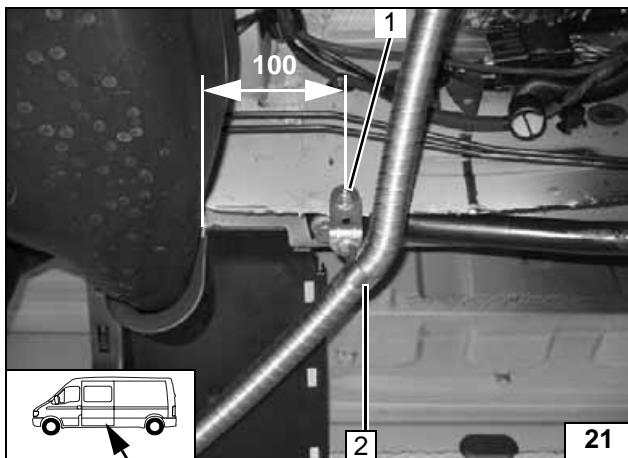

- 1 Angle bracket, M6x20 bolt, 7 mm dia. hole, large diameter washer, flanged nut
- 2 M6x20 bolt, clamp, flanged nut

Installing exhaust pipe

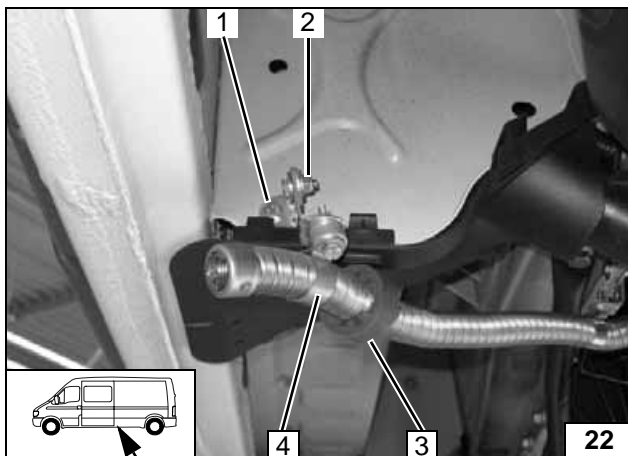

Position red (rt) rubber profile **3** on plastic trim piece and ensure sufficient distance to neighboring parts.



- 1 M6x20 bolt, angle bracket, existing hole, large diameter washer, flanged nut
- 2 M6x20 bolt, angle bracket, large diameter washer [2x], flanged nut
- 4 M6x30 bolt, clamp, shim 10, flanged nut

Installing exhaust pipe and end section

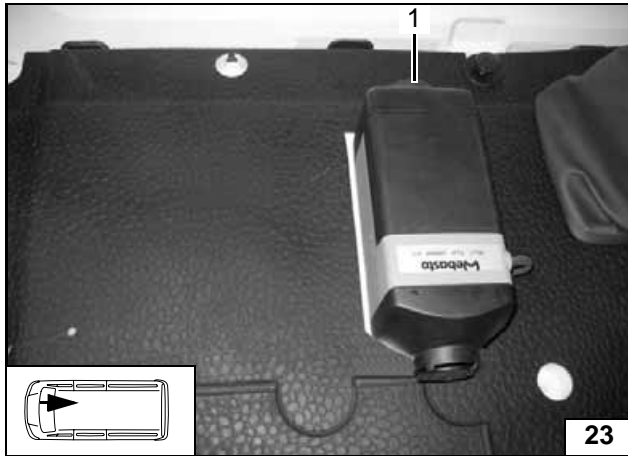
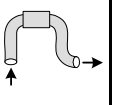

Heater unit without air ducting

- 1 Protective grill

Air ducting

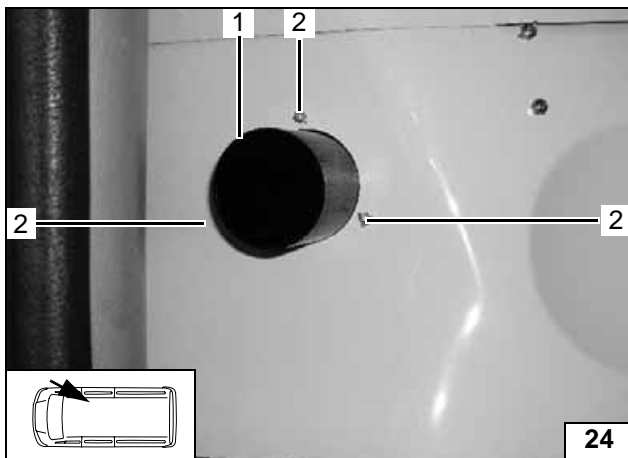

Heater unit with air ducting

Copy hole pattern with air outlet and punch out using special tool.

- 1 Air outlet
- 2 5 mm dia. hole, blind rivet 4.8 [3x each]



Air ducting

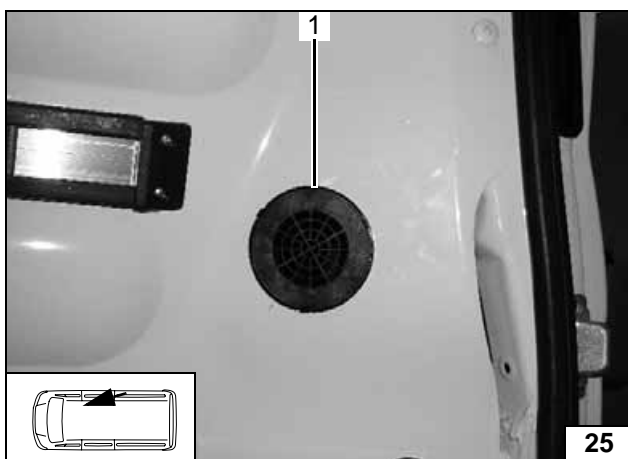

- 1 Cover

Air ducting

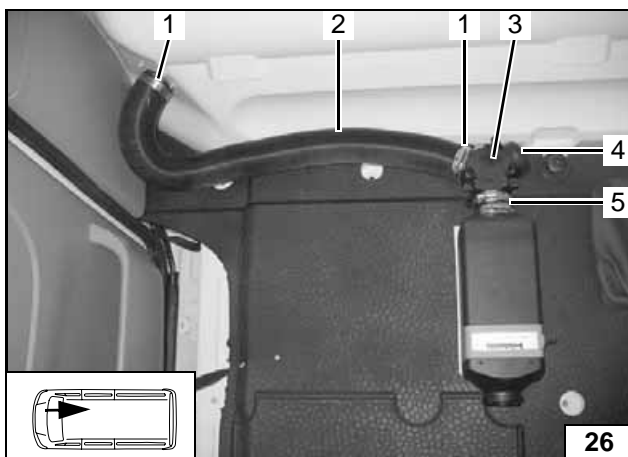

Check position of all components and adjust if necessary. Check that they have free clearance.

- 1 50-70 mm clamp [2x]
- 2 60 mm dia. flexible tube, 760 mm long
- 3 Distribution flap, self-tapping screw [2x]
- 4 Rubber protective grill
- 5 60 mm dia. flexible tube, 40 mm long, 50-70 mm clamp [2x]



Air ducting



Electrical Connections

Fuse holder

1 2.5 mm dia. hole, fuse holder

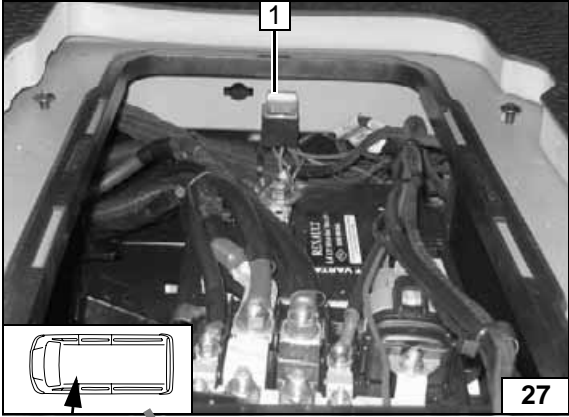

Cable pass through

Route wiring harness of heater unit 2 from underbody into battery box 1

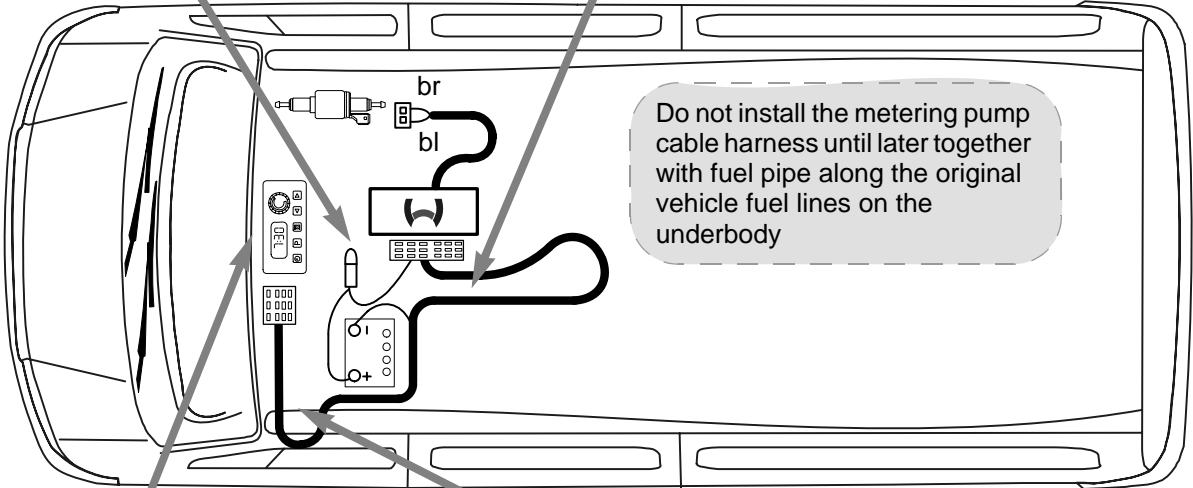
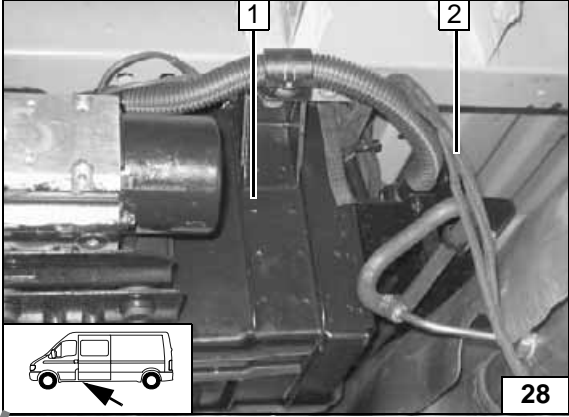

Wiring harness installation diagram

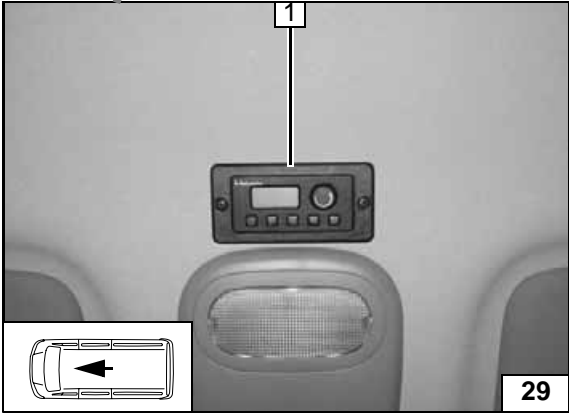

Heater control

1 Combination timer, installation frame

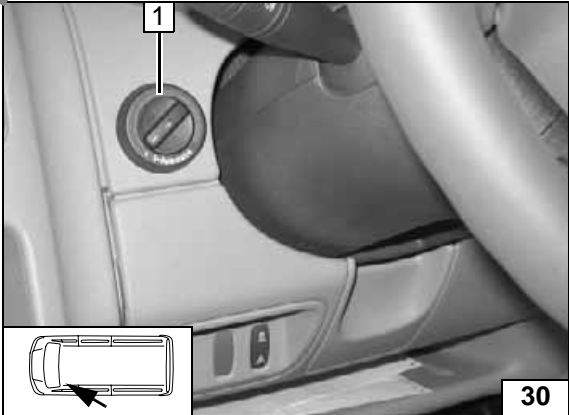

Heater control

1 Switch

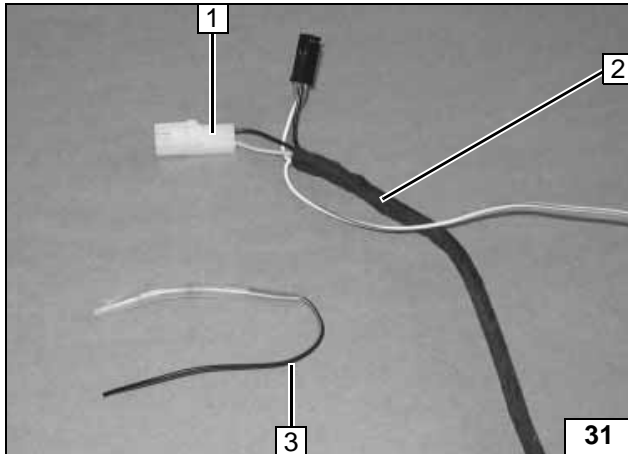

Temperature sensor option

Disconnect internal resistor 3 from wiring harness 2 and install connector 1 provided



**Con-
nection of
temperatur
e sensor**

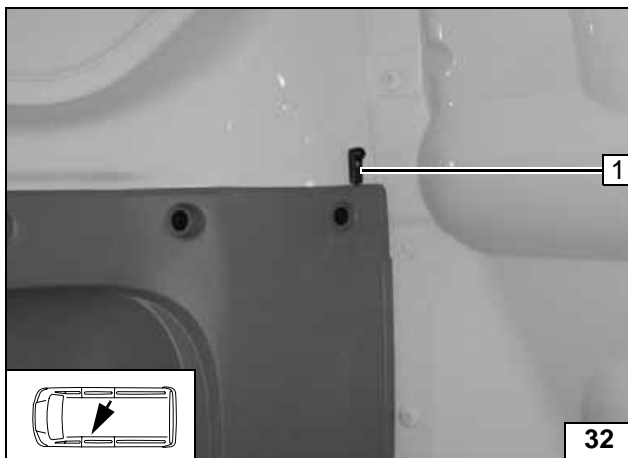

Route temperature sensor wire from installation location of combination timer or switch to installation location of temperature sensor. Installation location of temperature sensor 1 is a recommendation! Please coordinate installation location with customer prior to installation.



**Con-
nection of
temper-
ature
sensor**

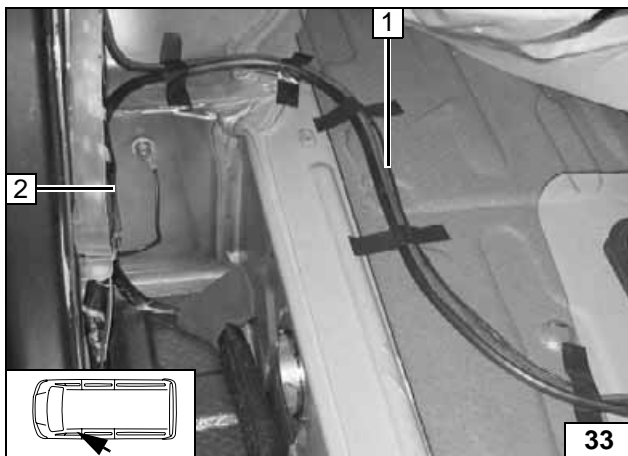

Routing wiring harnesses

Secure wiring harness with installation strap.

- 1 Wiring harness of heater control
- 2 Wiring harness of temperature sensor AT 2000 ST (option)



**Routing
wiring
harness**

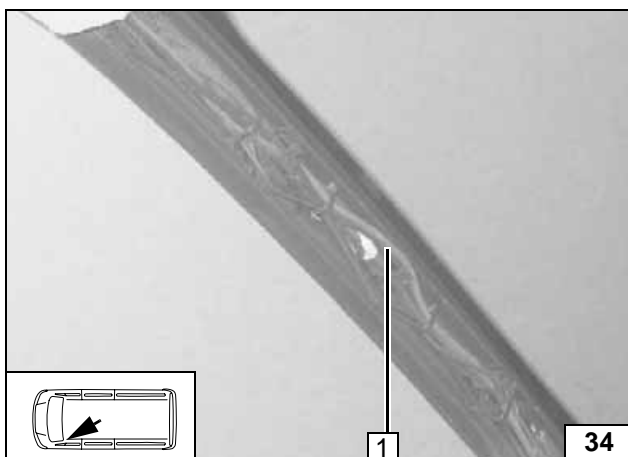

Route wiring harness 1 from combination timer along original vehicle wiring harnesses of left-hand A-pillar to fuse carrier.



**Routing
wiring
harness**

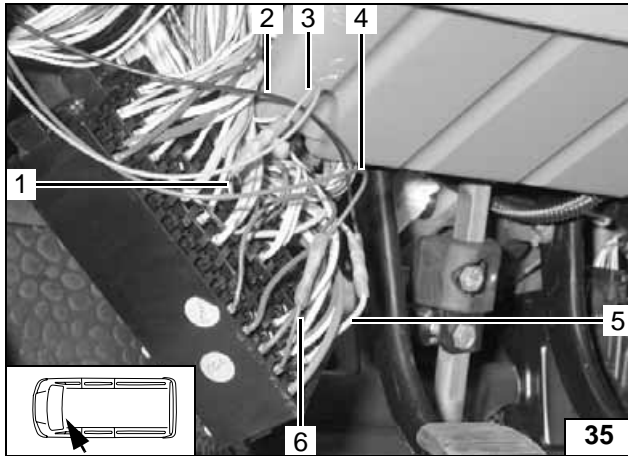

Connection of combination timer up to 2006 model

Observe connection diagram on page 19 and 20.

- 1 Blue (bl) wire of fuse for right-hand parking light
- 2 Black (sw) wire for Term. 15A of combination timer
- 3 Gray (gr) wire of Term. 58 of combination timer
- 4 Red (rt) wire of Term. 30 of combination timer
- 5 Yellow (ge) wire of fuse for socket outlet
- 6 Red (rt) wire of fuse for instrument cluster



**Con-
nection of
combi-
nation
timer**

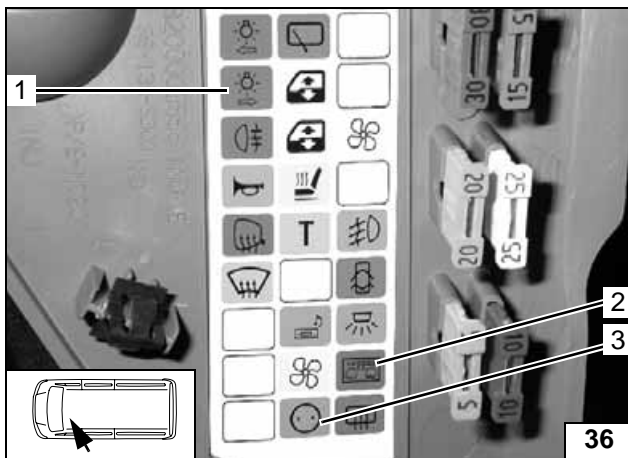

- 1 Fuse of right-hand parking light
- 2 Fuse of instrument cluster
- 3 Fuse of socket outlet

**Con-
nection of
combi-
nation
timer**

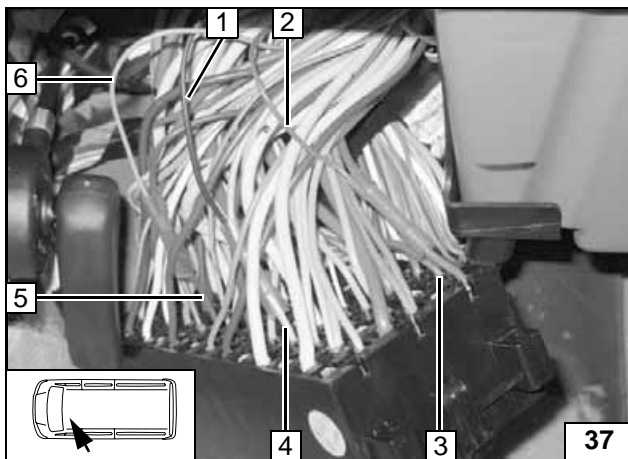

Connection of combination timer from 2007 model

Observe connection diagram on page 19 and 20.

- 1 Black (sw) wire for Term. 15A of combination timer
- 2 Red (rt) wire of Term. 30 of combination timer
- 3 Red (rt) wire of fuse for interior lighting
- 4 Yellow (ge) wire of fuse for socket outlet
- 5 Blue (bl) wire of fuse for right-hand parking light
- 6 Gray (gr) wire of Term. 58 of combination timer



**Con-
nection of
combi-
nation
timer**

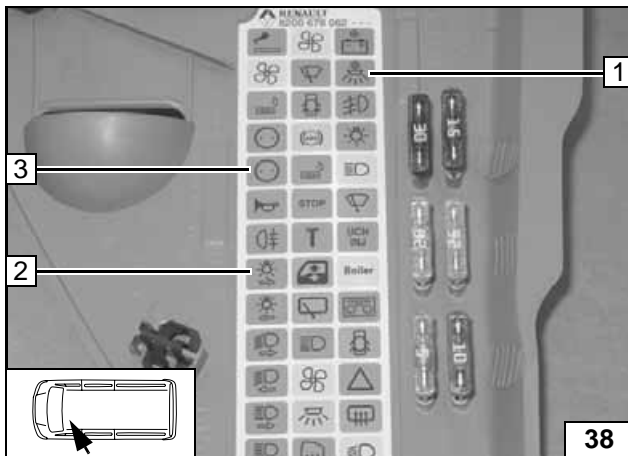

- 1 Fuse of interior lighting
- 2 Fuse of right-hand parking light
- 3 Fuse of socket outlet

**Con-
nection of
combi-
nation
timer**

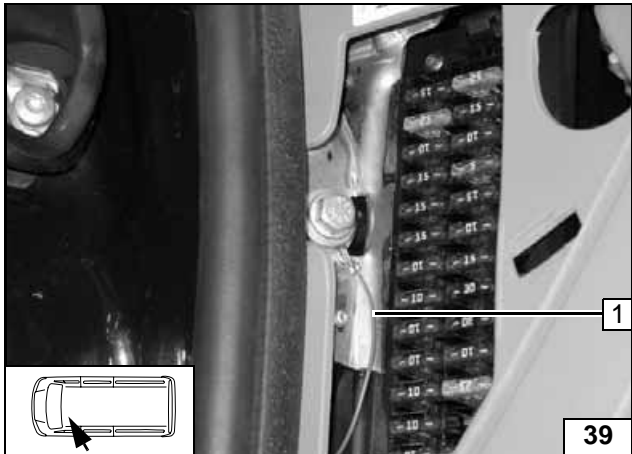

1 Brown (br) wire of Term. 31 of combination timer

Con-
nection of
combi-
nation
timer

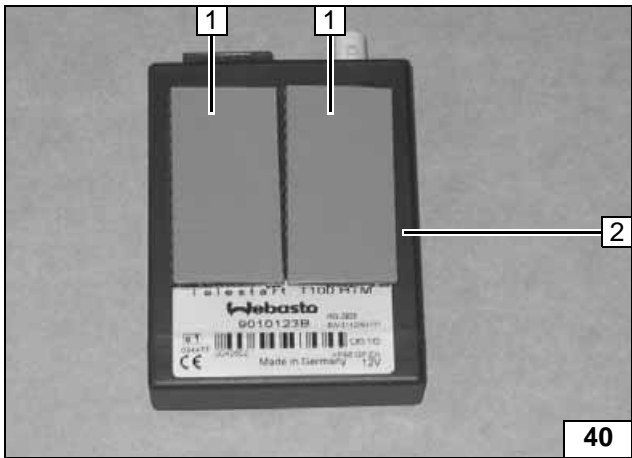

Remote option (Telestart)

- 1 Adhesive tape [2x]
- 2 Receiver

Preparing
receiver

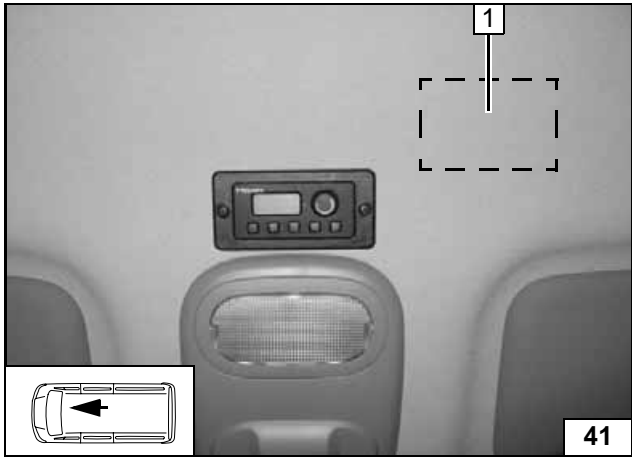

Receiver 1 fastened on inside of headliner with adhesive tape



Installing
receiver

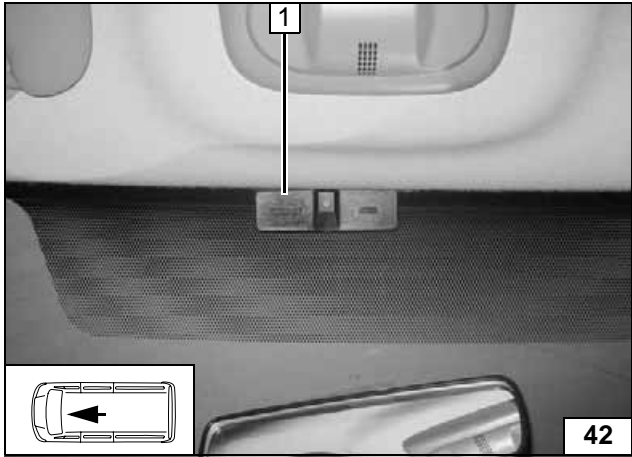

1 Antenna

Installing
antenna

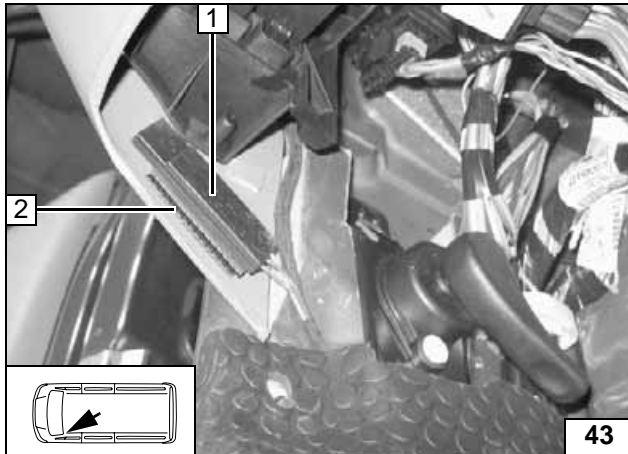

- 1 Temperature sensor
- 2 Adhesive tape

Installing temperature sensor T 100 HTM

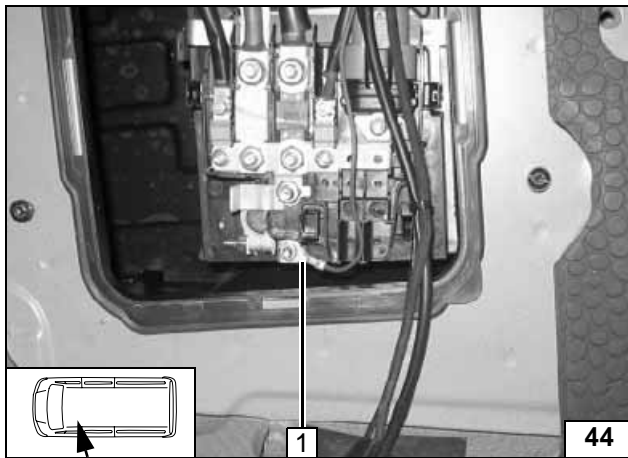

Connection to battery

- 1 Red (rt) wire, claw cable lug, flanged nut

Connection to positive battery terminal

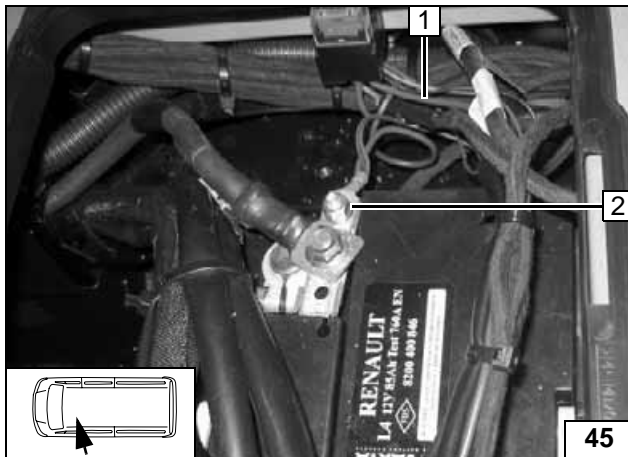

Shorten red (rt) wire 1 to heater unit, crimp on flat spring contact and install in fuse holder.

- 2 Brown (br) wire, claw cable lug, flanged nut



Connection to negative battery terminal



Connection Diagram for Combination Timer

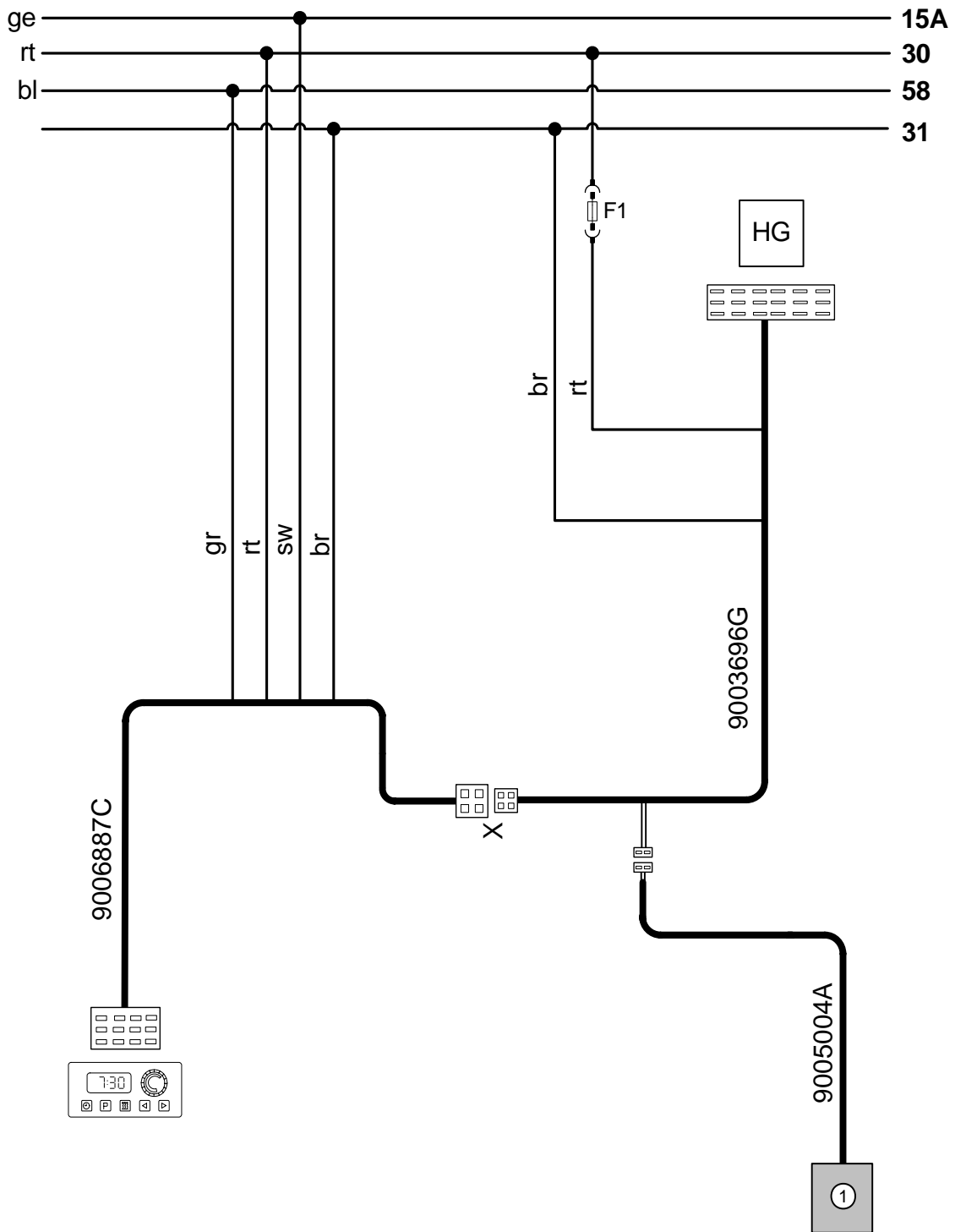

Con-
nection
Diagram
for Combi-
nation
Timer

<p>X = Connector is connected with matching colors. Heater unit = AT2000ST! 1 = Temperature sensor of heater unit! F1 = 15A!</p>	<p>rt = red br = brown sw = black bl = blue gr = gray</p>
---	--





Connection Diagram for Combination Timer and Telestart

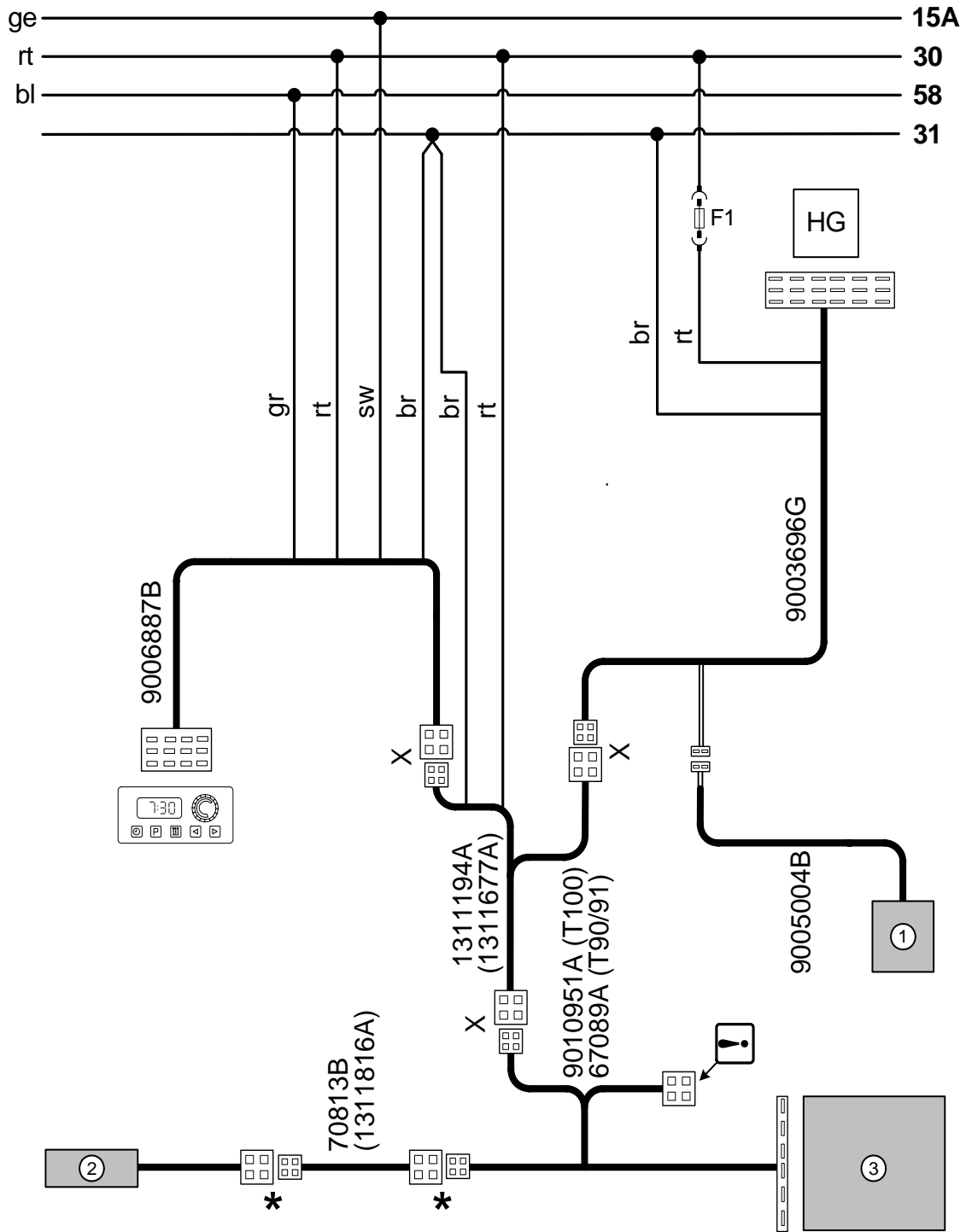

Con-
nection
Diagram
for Combi-
nation
Timer and
Telestart

<p>X = Connector is connected with matching colors. * = Connector is connected with change from yellow (ge) to purple (li) Heater unit = AT2000ST! 1 = Temperature sensor of heater unit! 2 = Temperature sensor for Telestart only with T100 3 = Telestart F1 = 15A! = tie back</p>	<p>rt = red br = brown sw = black bl = blue gr = gray ge = yellow li = purple</p>
---	--



Operating Instructions for End Customer

Please remove page and add to the vehicle operating instructions.

Note: Observe setting for permanent heating option.

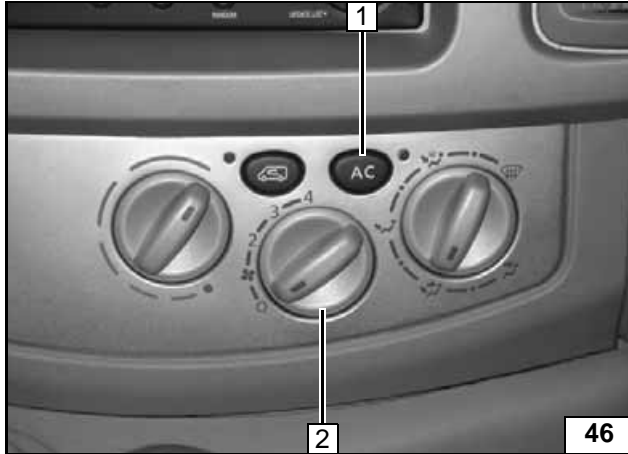

Turn ignition key into Radio position (15A)

- 1 Set AC button to "OFF"
- 2 Set fan to level "0"

Drilling Template
(Use entire page
as template)

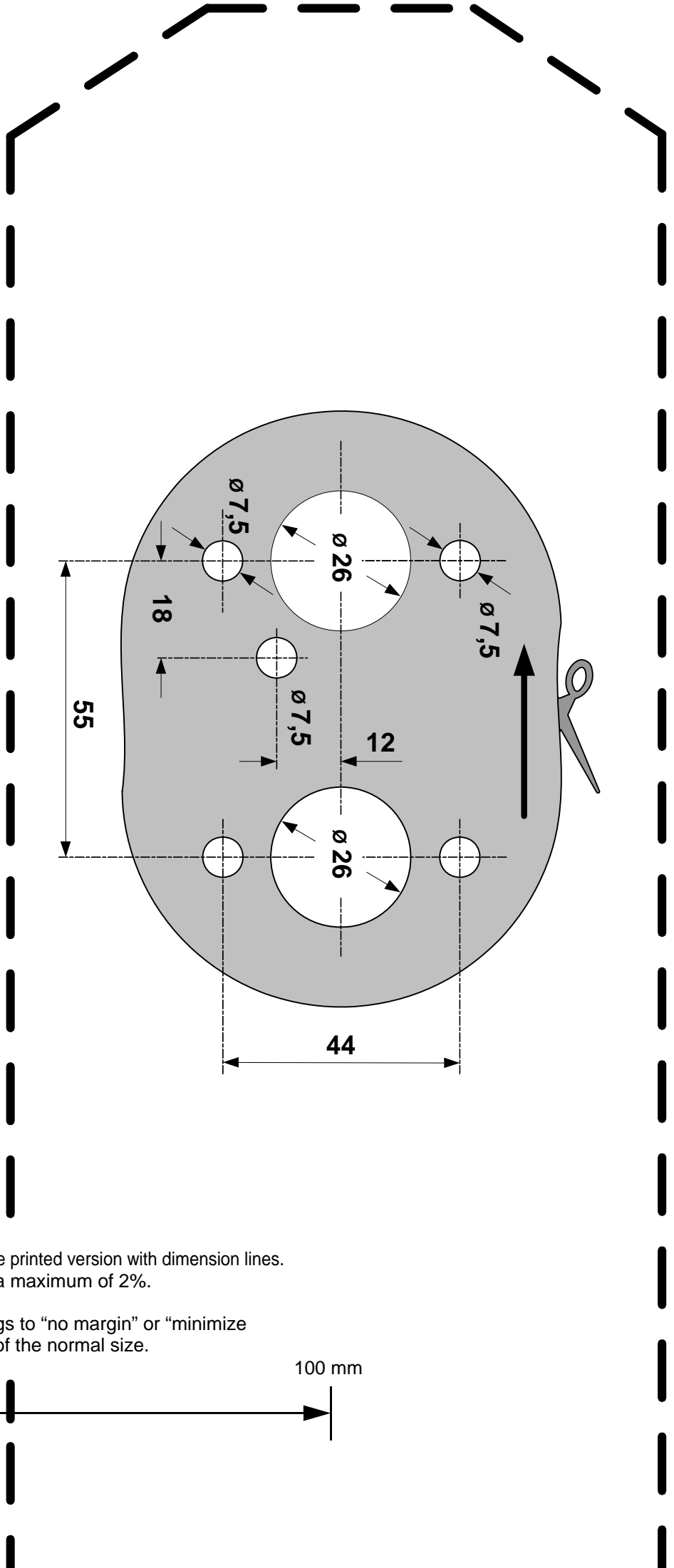

100 mm



Scale 1:1

Compare the size of the printed version with dimension lines.
Permitted tolerance a maximum of 2%.

Set the printer settings to "no margin" or "minimize
margins" and 100% of the normal size.

100 mm

0