

Water Heater Unit



Thermo Top E Additional Heater e1 00 0003

Thermo Top C Additional Heater e1 00 0002

Thermo Top P Additional Heater e1 00 0104

Installation Instructions

Nissan X-Trail

Diesel
from Model Year 2008
Left-hand drive vehicle



WARNING!

Hazard warning:

Incorrect installation or repair of Webasto heating systems may cause a fire or result in the emission of carbon monoxide, which can be fatal. Serious or fatal injuries can be caused as a result.

Specialist company training, technical documentation, specialized tools and equipment are required to install and repair Webasto heating and cooling systems.

NEVER attempt to install or repair Webasto heating or cooling systems if you have not successfully completed the company training and thereby acquired the required technical skills, or if you do not have access to the required technical documentation, tools and equipment needed to carry out correct installation and repairs.

ALWAYS follow all Webasto installation and repair instructions and observe all warnings.

Webasto does not accept any liability for defects and damage that are attributable to installation by untrained staff.

Table of Contents

Validity	2	Remote option (Telestart)	10
Heater Unit/Installation Kit	3	Remote option (Thermo Call)	11
Foreword	3	Preparing heater unit	12
General Instructions	3	Preparing installation location	12
Special Tools	3	Installing heater unit	13
Explanatory Notes on Document	4	Coolant for diesel engine	15
Preliminary Work	5	Combustion air	19
Heater unit installation location	5	Fuel	20
Preparing electrical system	6	Exhaust gas	22
Electrical system	7	Operating Instructions for End Customer	24
Automatic air-conditioning fan controller	8		

Validity

Manufacturer	Model	Type	EG-BE No./ABE
Nissan	X-Trail	T31	e1 * 2001/116 * 0432 * ...

Engine type	Engine model	Output in kW	Displacement in cm ³
M9R	Diesel	110	1995
M9R	Diesel	127	1995

Vehicle and engine types, equipment variants and national specifications not listed in these installation instructions have not been tested. However, installation according to these installation instructions may be possible.

The installation location of a digital timer and summer/winter switch should be confirmed with the end customer before installation.

Heater Unit/Installation Kit

Quantity	Description	Order No.:
1	Nissan-specific delivery scope	See Nissan price list
1	Installation kit for Nissan X-Trail Diesel	xxxxxxA

Also required:

Quantity	Description	Order No.:
1	Heater control according to Nissan price list	See Nissan price list

Heater unit recommended for the respective vehicle class:

Vehicle	Heater unit
Compact car	Thermo Top E
Mid-size car, station wagon	Thermo Top C
Full-size car, van, offroader	Thermo Top P



The selection of the heater unit is based on the passenger compartment size of the vehicle and the level of comfort required by the customer!

Foreword

These installation instructions apply to Nissan X-Trail Diesel vehicles - for validity, see page 2 - from model year 2008 and later, assuming technical modifications to the vehicle do not affect installation, any liability claims excluded. Depending on the vehicle version and equipment, modifications may be necessary during installation with respect to these installation instructions.

However, the stipulations in the "installation instructions" and "operating and maintenance instructions" for the *Thermo Top C/P/E* must always be observed.

The corresponding rules of technology and any information from the vehicle manufacturer should be observed during the installation work.

General Instructions

Installation should be carried out according to the general, standard rules of technology. Unless specified otherwise, fasten hoses, lines and wiring harnesses to original vehicle lines and wiring harnesses using cable ties.

Sharp edges should be fitted with edge protectors (split-open plastic hose).

Spray unfinished body areas, e.g. drilled holes, with anti-corrosion wax (Tectyl 100K, Order No. 111329).

Special Tools

- Torque wrench for 2.0 - 10 Nm
- Hose clamping pliers
- Metric thread-setter kit

Explanatory Notes on Document

To provide you with a quick overview of the individual working steps, you will find an identification mark on the outside top right corner of the page in question.

Mechanical system

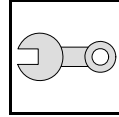

Electrical system

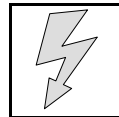

Water

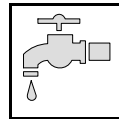

Fuel

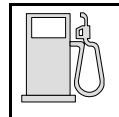

Exhaust gas

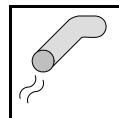

Combustion air

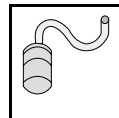

Special features are highlighted using the following symbols:



Specific risk of injury or fatal accidents.



Specific risk of damage to components.



Specific risk of fire or explosion.



Reference to general installation instructions of Webasto components or to the manufacturer's vehicle-specific documents.



Reference to a special technical feature.

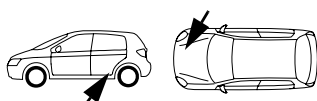

The arrow in the vehicle icon indicates the position on the vehicle and the viewing angle.

All dimensions are in mm!

Tightening torque of hose clamps = 2.0 + 0.5 Nm!

Tightening torque of Ejet screws, Ejet studs = 10 Nm!

Preliminary Work

WARNING!

- Open the fuel tank cap, ventilate the tank.
- Close the tank cap again.
- Disconnect the battery "earth" or "ground" connection.
- Depressurize the cooling system.
- Copy the factory number from the original type label to the duplicate type label.
- Remove years that do not apply from the duplicate label.
- Attach the duplicate label (type label) in the appropriate place.
- Completely remove the battery
- Remove the air filter together with the intake hose.
- Remove the trim in the right footwell
- Remove the fuse and relay box
- Remove the A/C control panel.
- Remove the bumper.
- Remove the underride protection
- Open the right-hand fuel sender service lid.

Remove page 24 "Operating Instructions for End Customer" and add to the vehicle operating instructions.

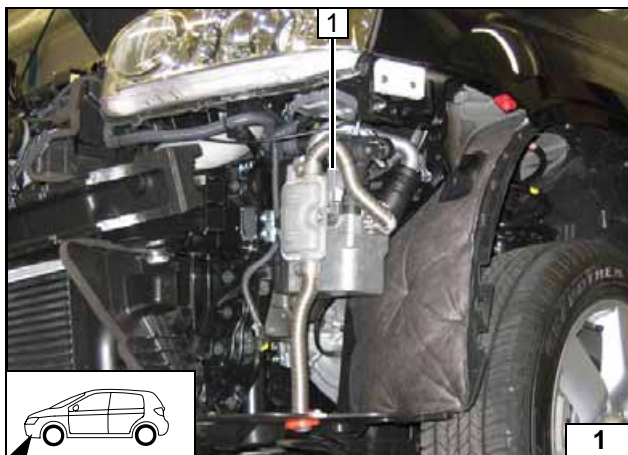

Heater unit installation location

- 1 Heater unit

Installation
location

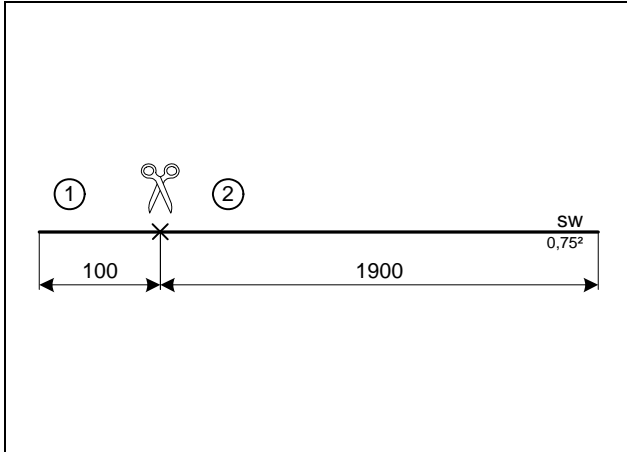

Preparing electrical system

Only with automatic air-conditioning

Wire section 1 and 2 will be required later for connecting fuse F4.



Cutting wires to length

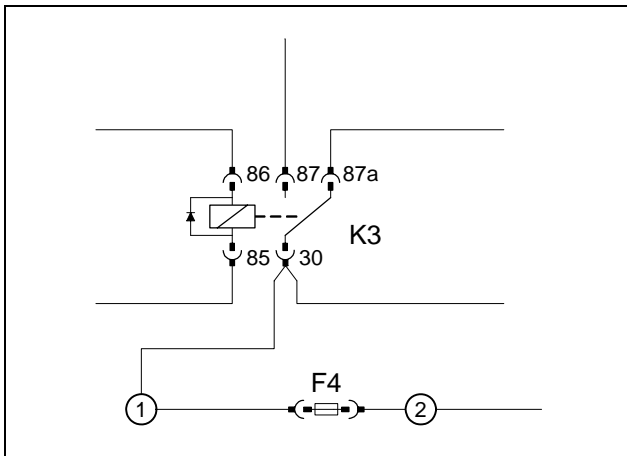

Produce connections as shown in wiring diagram. Install wire section 2 in the protective sleeving provided.



Preparing fuse F4



Electrical system

Digital timer / summer/winter switch option

- 1 Digital timer
- 2 Summer/winter switch, drilled hole 12 mm dia.

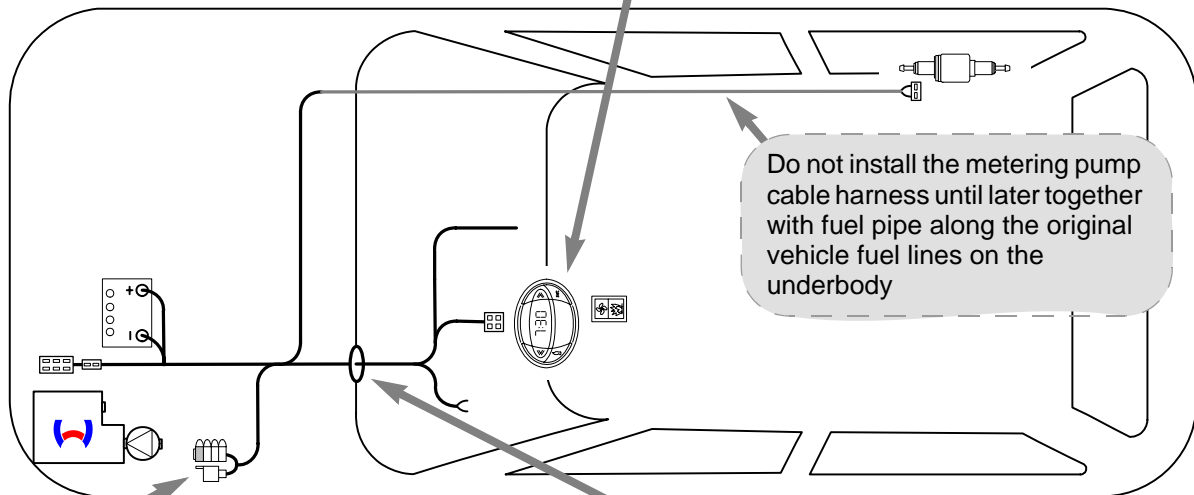
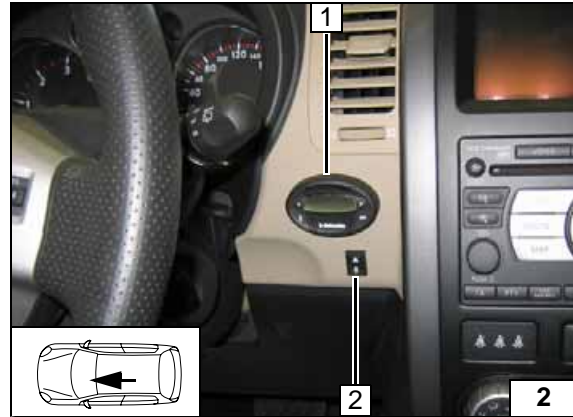

Wiring harness installation diagram

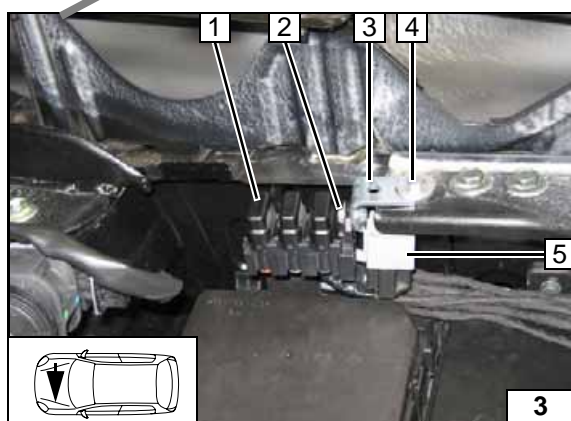

Fuse holder, relay K3

- 1 Fuse holder
- 2 Retaining plate of fuse holder, M5x12 bolt, washer, angle bracket
- 3, K3 relay
- 5, M5 flanged nut
- 4 M6x20 bolt, large diameter washer, existing hole, M6 flanged nut

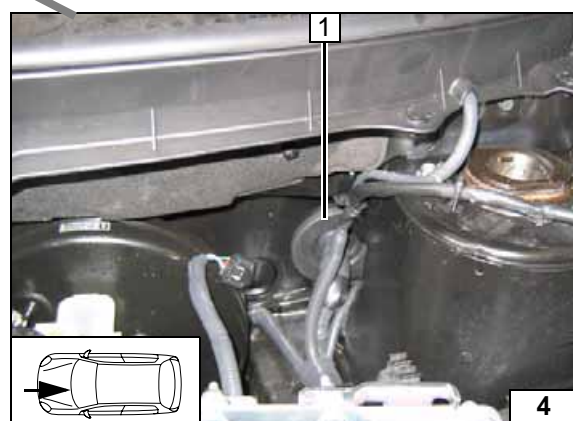

Wiring harness pass through

- 1 Protective rubber plug



Automatic air-conditioning fan controller



Wiring diagram

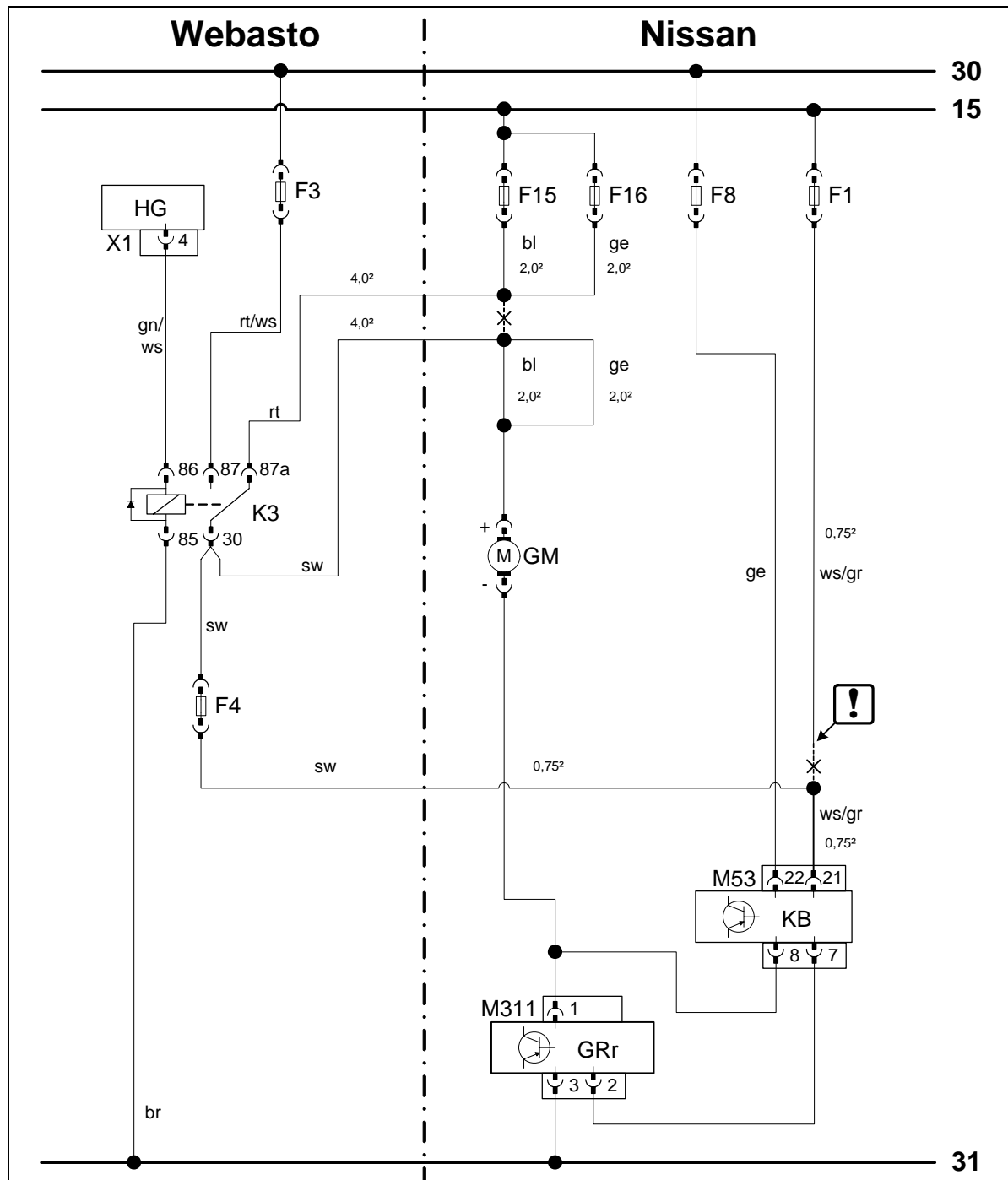

Webasto components		Vehicle components		Colors and symbols	
HG	Heater unit TT-C/E	GM	Fan motor	rt	red
X1	6-pin heater unit connector	KB	Air-conditioning control panel	ws	white
F3	25 A fuse	M53	40-pin connector KB	sw	black
K3	Fan relay	GRr	Fan controller	br	brown
F4	10 A fuse	M311	4-pin connector, GRr	gn	green
		F1	10 A fuse	bl	blue
		F8	10 A fuse	ge	yellow
		F15	15 A fuse	!	Insulate wire ends and tie back
		F16	15 A fuse	X	Cutting point
					Wiring colors may vary.

Legend

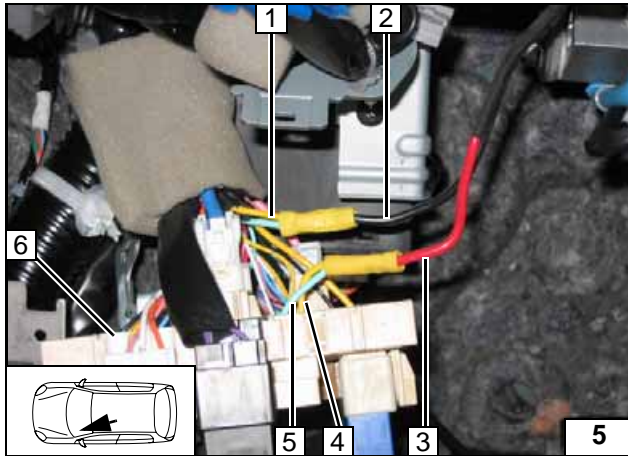
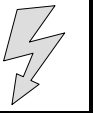

Connection on fuse carrier **6** behind fuses F15 and F16. Produce connections as shown in wiring diagram.

- 1 Yellow and blue (ge/bl) wire of fan motor
- 2 Black (sw) wire from K3/30
- 3 Red (rt) wire from K3/87a
- 4 Yellow (ge) wire from fuse 16
- 5 Blue (bl) wire of fuse 15



Con-necting fan-motor

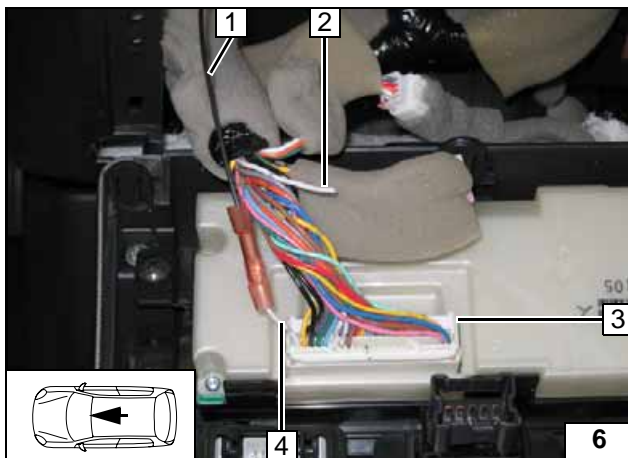

Connection to 40-pin connector **3** from A/C control element. Produce connections as shown in wiring diagram.

- 1 Black (sw) wire from F4
- 2 Insulate and tie back white/green (ws/gr) wire
- 4 White/green (ws/gr) wire, Pin 21



Con-necting A/C control panel

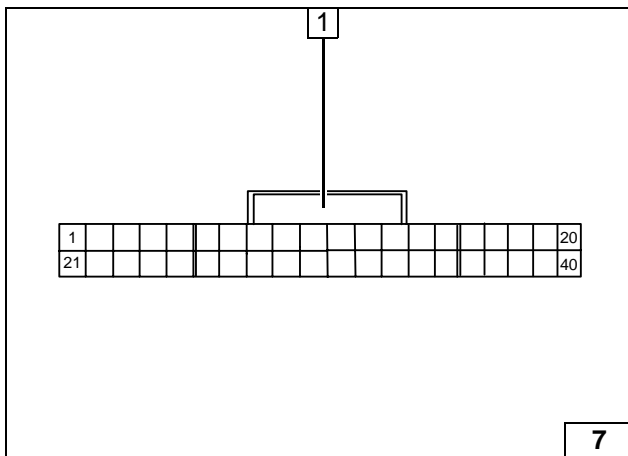

- 1 Connector M53 on contact side



View of connector M53

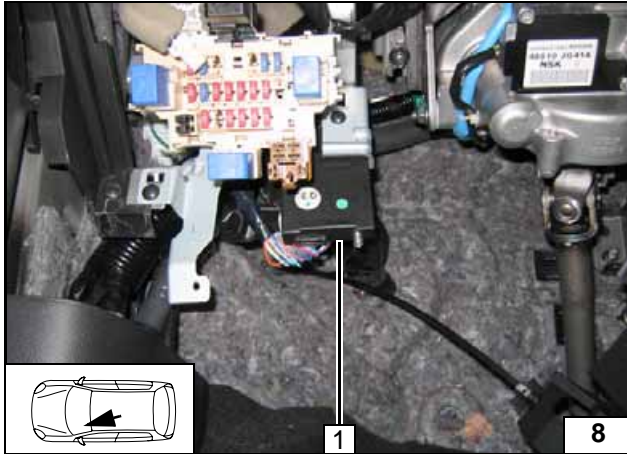

Remote option (Telestart)

1 Fasten receiver with double-sided adhesive tape



Installing receiver

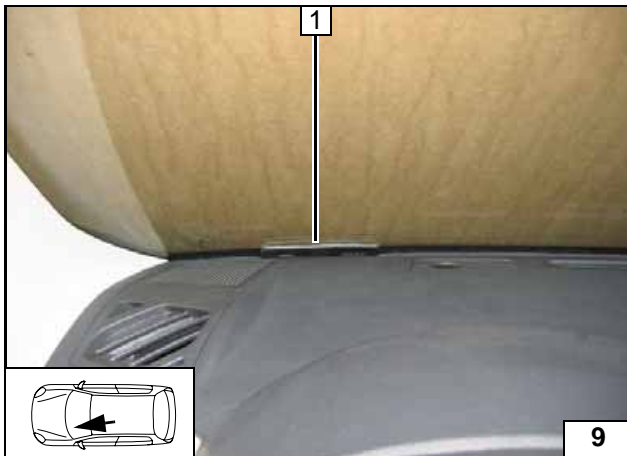

1 Antenna

Installing antenna

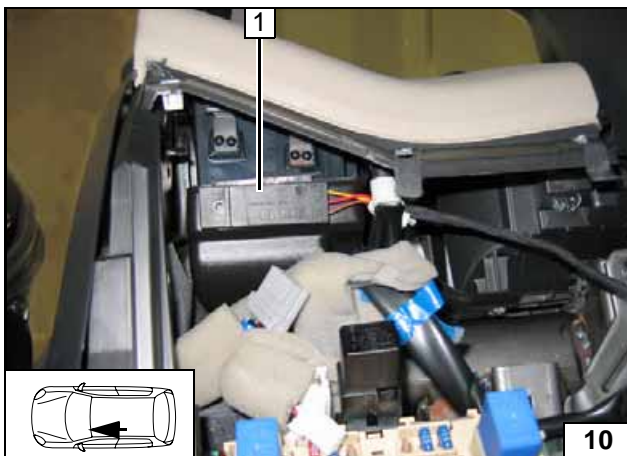

Temperature sensor for HTM100 only

1 Fasten temperature sensor with double-sided adhesive tape



Installing temperature sensor

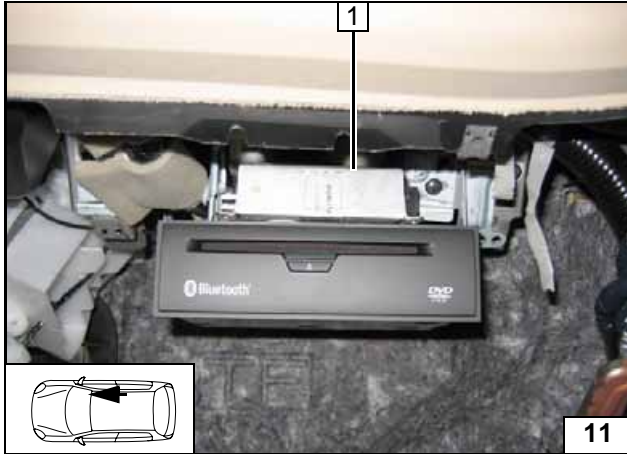

Remote option (Thermo Call)

1 Fasten receiver with double-sided adhesive tape

Installing receiver

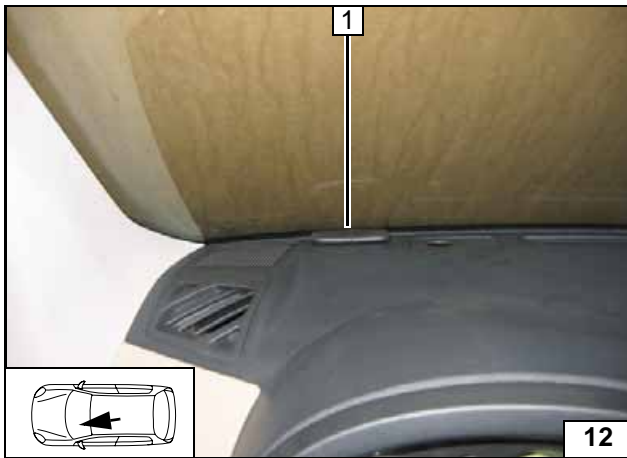

1 Antenna

Installing antenna



1 Pushbutton

Installing push button

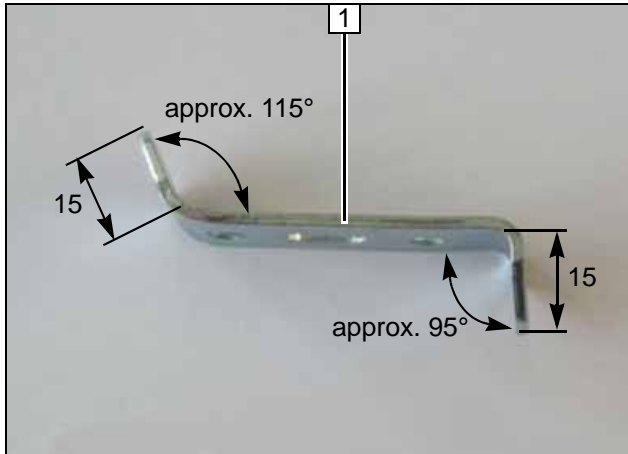
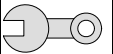

Preparing heater unit

- 1 Perforated bracket

Bending perforated bracket

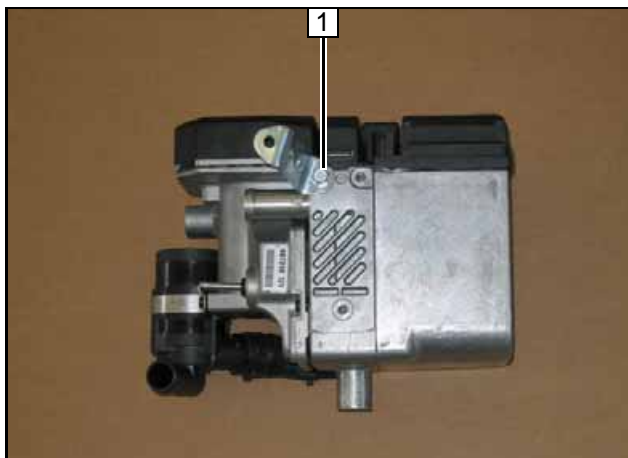

Loosely mount perforated bracket with 90° angle bracket on heater unit.



- 1 Eject screw

Installing perforated bracket

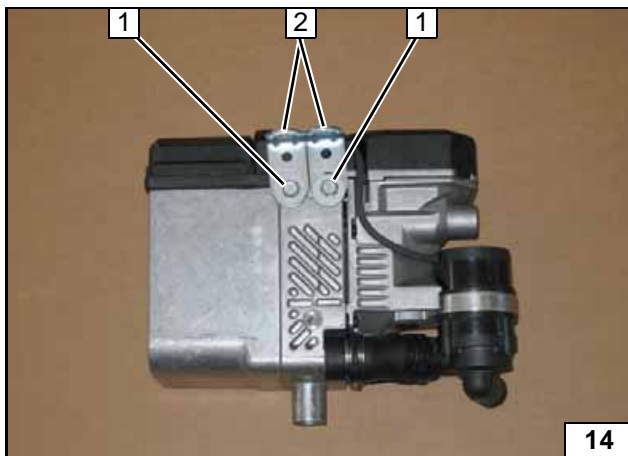

- 1 Eject screw, large diameter washer [2x each]
- 2 Angle bracket [2x]

Installing angle bracket

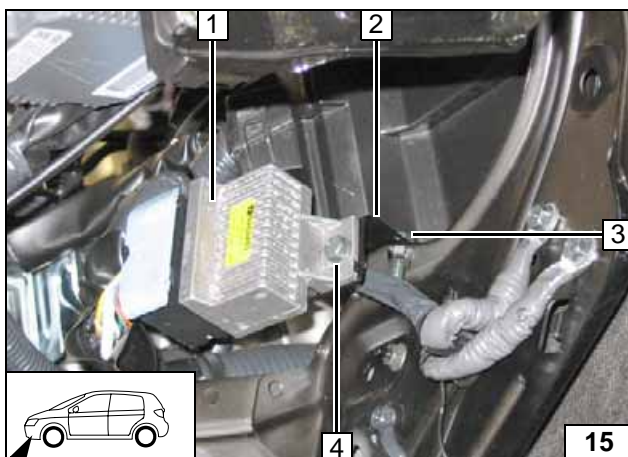

Preparing installation location

- 1 Resistor
- 2 Discard bracket
- 3 Discard original vehicle bolt
- 4 Original vehicle bolt will be reused

Moving resistor

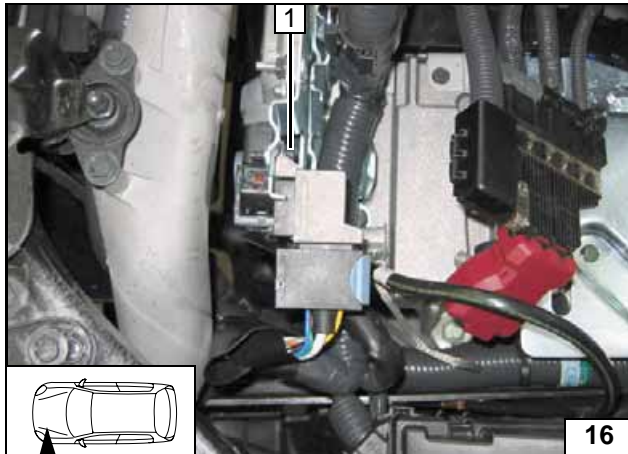
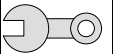

- 1 Original vehicle bolt on existing threaded hole

Moving resistor

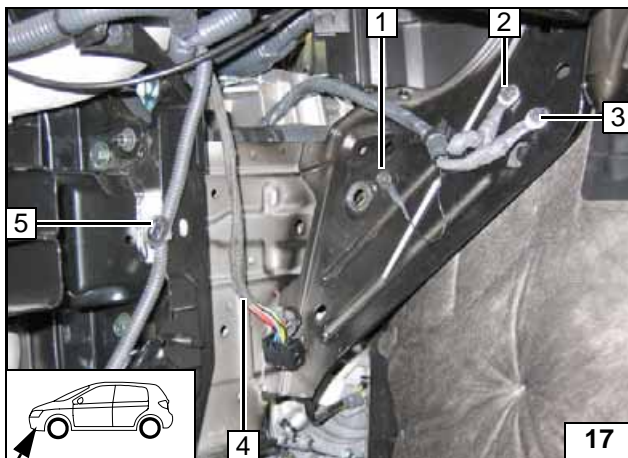

- 1 Disconnect ground wire, bolt will be reused
- 2 Disconnect ground wire
- 3 Disconnect ground wire
- 4 Wiring harness of heater unit
- 5 Remove clip of wiring harness



Moving ground wires

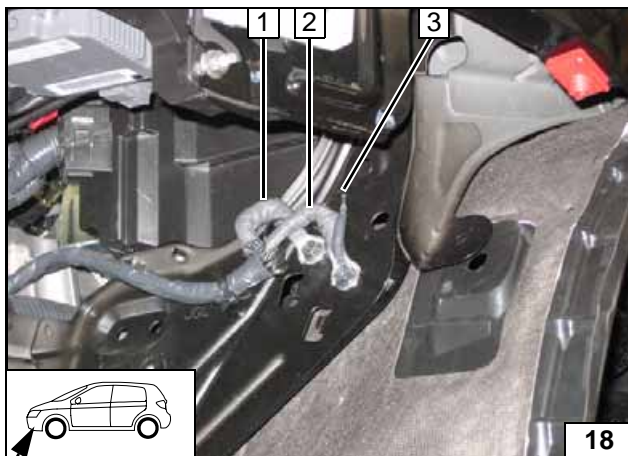

- 1 Ground wire
- 2 Ground wire
- 3 Ground wire

Moving ground wires

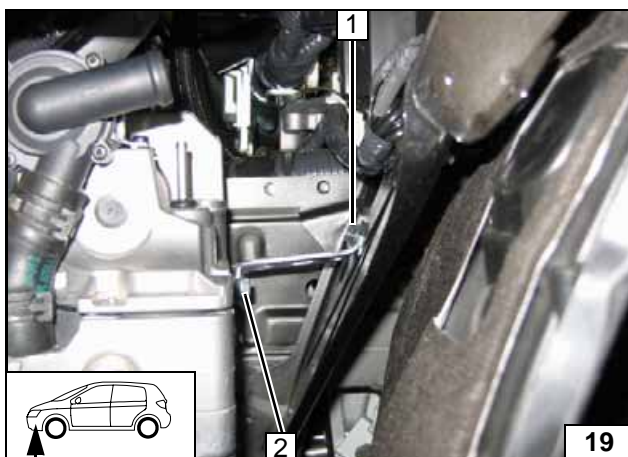

Installing heater unit

- 1 Original vehicle bolt on existing threaded hole
- 2 Tighten Eجت screw

Installing heater unit

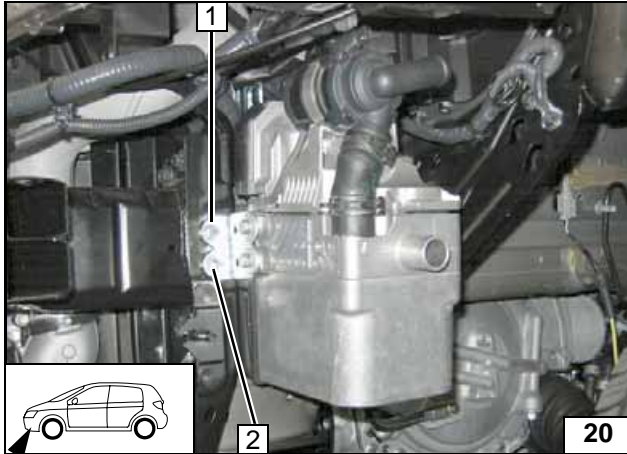
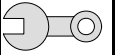

- 1 M6x20 bolt, M6 flanged nut
- 2 Copy hole pattern, drill 6.5 mm dia. hole in cross member

Installing heater unit

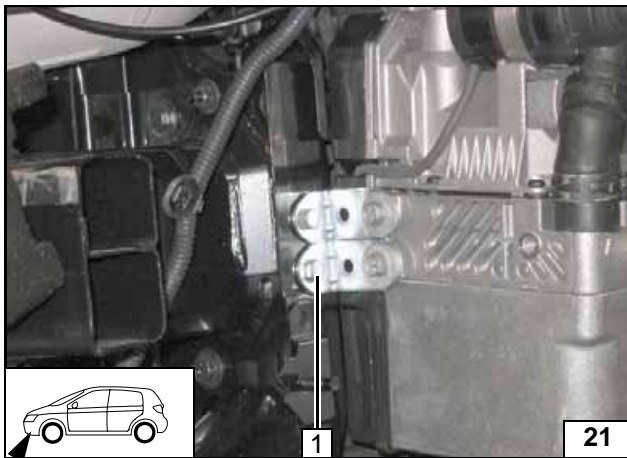

- 1 M6x20 bolt, M6 flanged nut

Installing heater unit

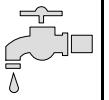

Coolant for diesel engine

WARNING!

Any coolant running off should be collected using an appropriate container. Install hoses so that they are kink-free. Unless specified otherwise, always fasten using cable ties. Position clamps so that no other hose can be damaged! When installing the coolant hose, the heater unit must be filled with coolant.

The connection should be "inline" based on the following diagram:

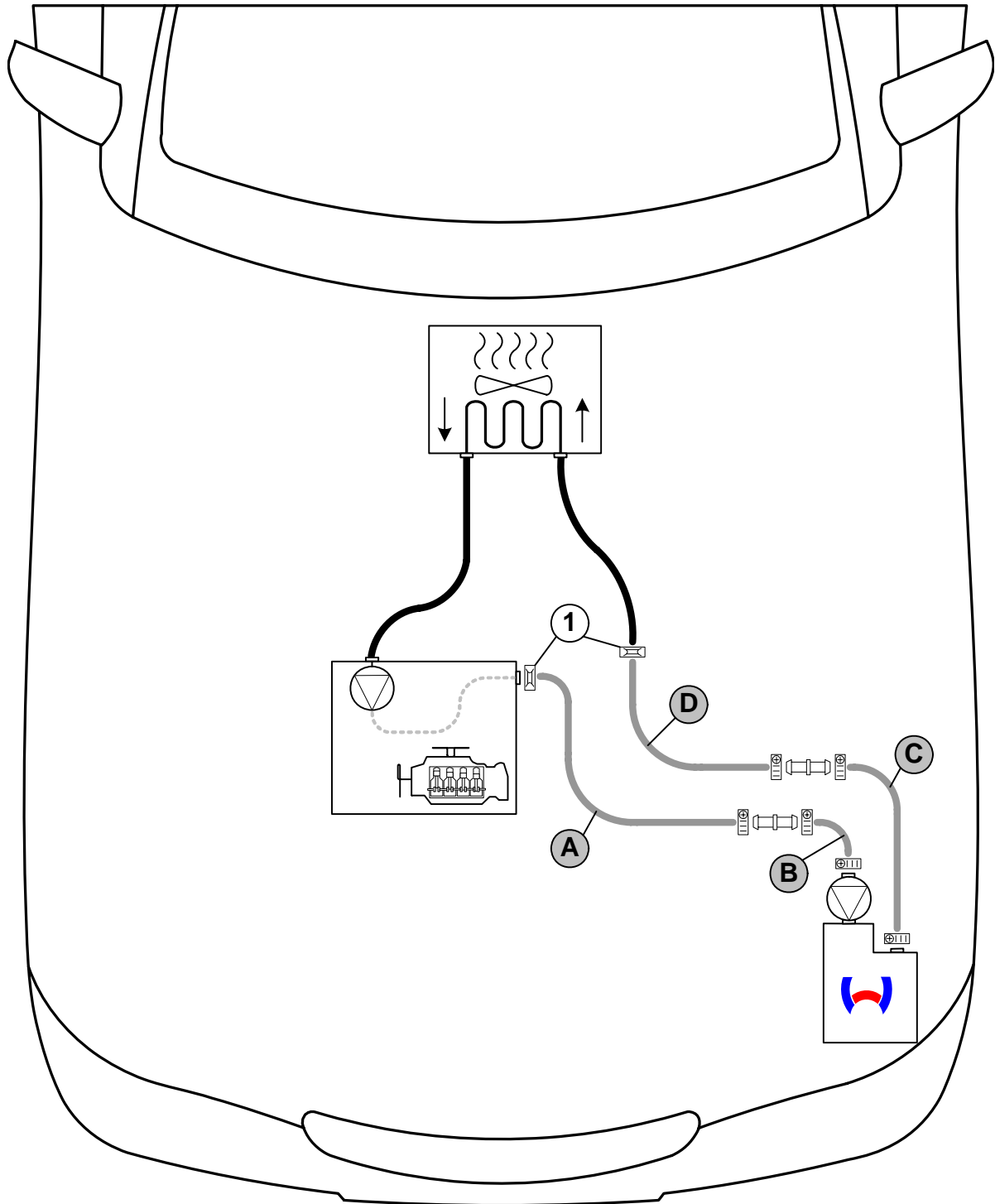

Coolant routing diagram

All connecting pipes = 20x20 dia..
 All hose clamps = 20-27 mm dia.!
 1 = Original vehicle spring clips .



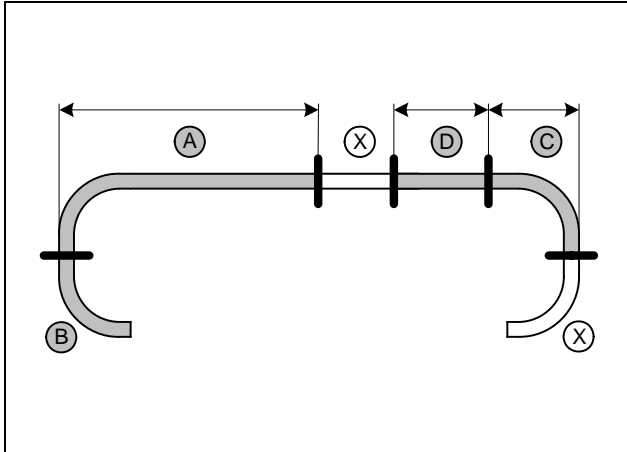

a = 700
c = 110
d = 600

Discard section X

Cutting coolant hoses to length

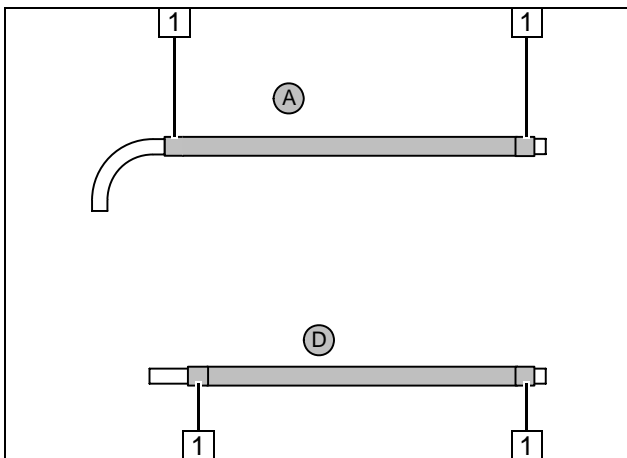

Push braided protection hoses onto hose A and D and cut to length.
Cut heat shrink plastic tubing to size and shrink.



1 25 mm long heat shrink plastic tubing [4x]

Preparing coolant hoses

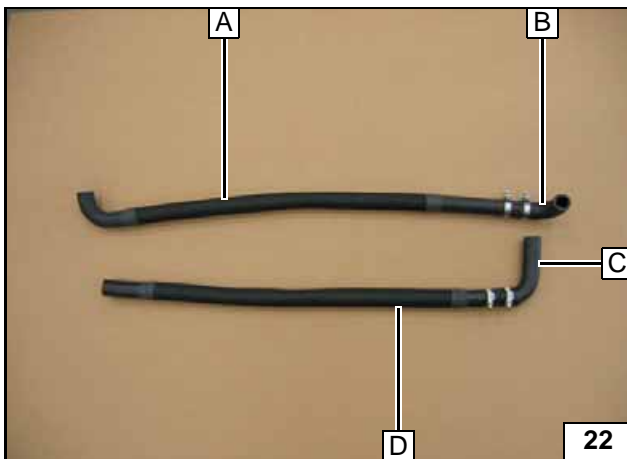

Pre-mounting hoses

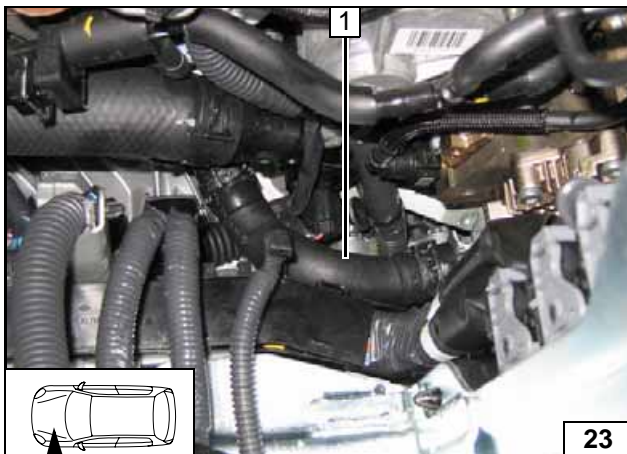

1 Discard hose section; original vehicle clamp will be reused

Cutting point

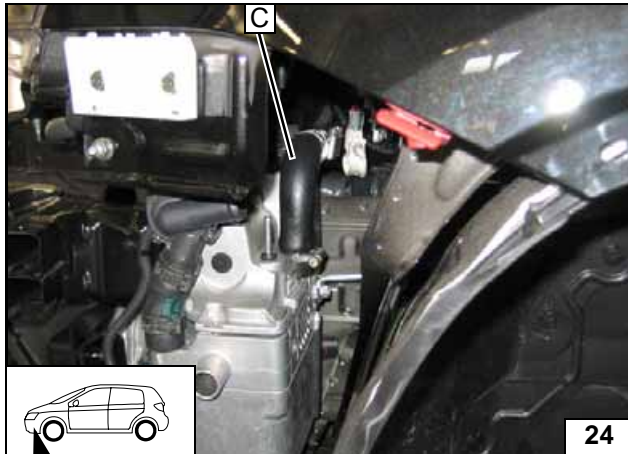

Con-
nection to
heater unit

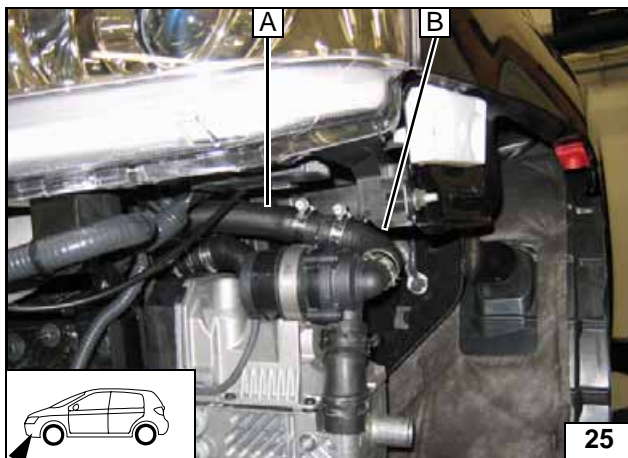

Con-
nection to
heater unit

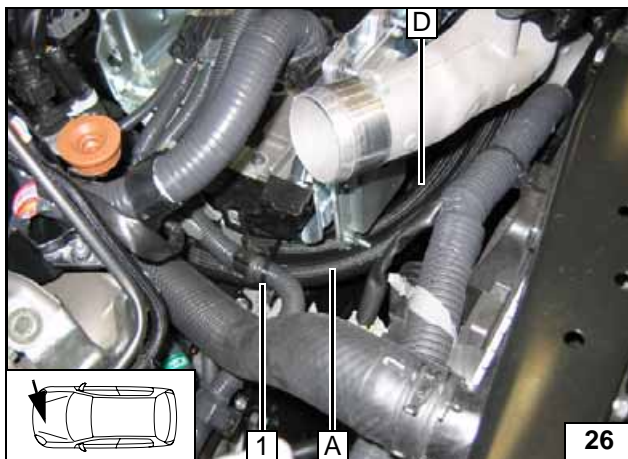

1 Cable tie

Routing in
engine
compart-
ment

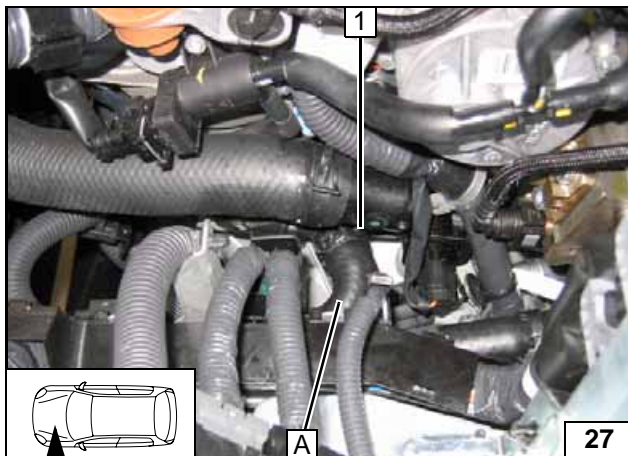

1 Original vehicle clamp

Con-
nection on
engine
outlet

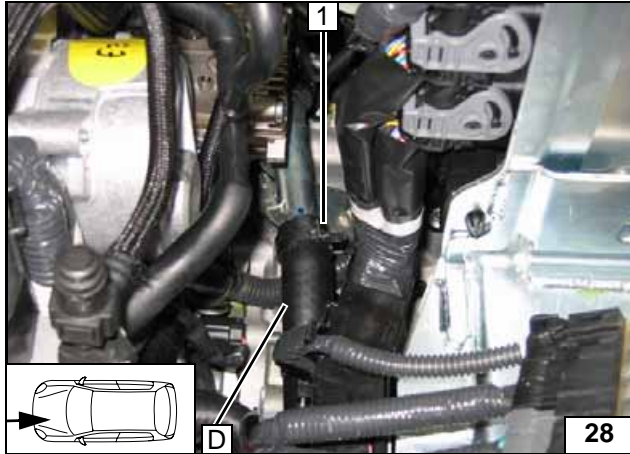

1 Original vehicle clamp

Con-
nection on
heat
exchanger
inlet

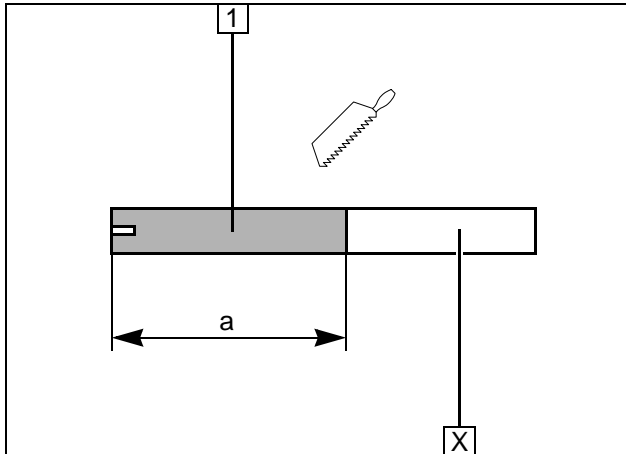
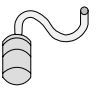

Combustion air

- 1 Combustion air pipe
a = 280

Discard section X

Cutting combustion air pipe to length

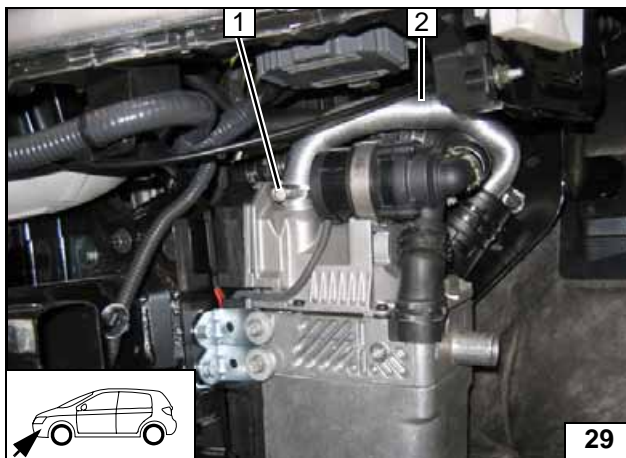

- 1 27 mm dia. clamp
- 2 Combustion-air intake pipe

Installing intake pipe

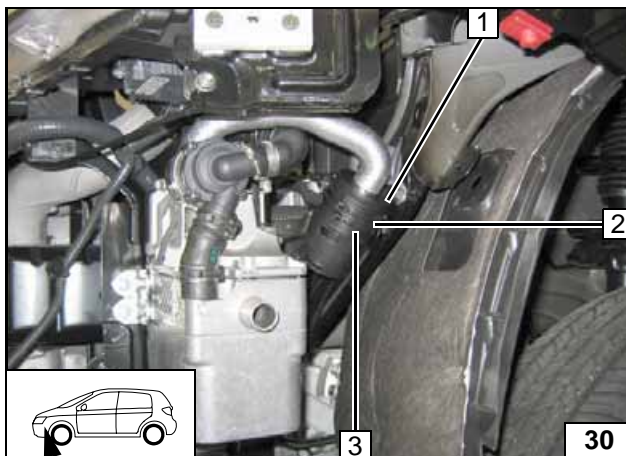

- 1 Intake muffler
- 2 Cable ties [2x] through guide slit
- 3 Cable ties [2x] through guide slit



Installing muffler



Fuel

CAUTION!

Open the vehicle's fuel tank cap, ventilate the tank and then re-close the tank lock.

Catch any fuel running off with an appropriate container.

Install fuel line and metering-pump wiring harness so that they are protected against stone impact. Unless specified otherwise, always fasten using cable ties. Mount the fuel line and wiring harness with rub protection on sharp edges.

WARNING!

The fuel line and wiring harness are routed to the metering pump in as shown in the wiring harness routing diagram.

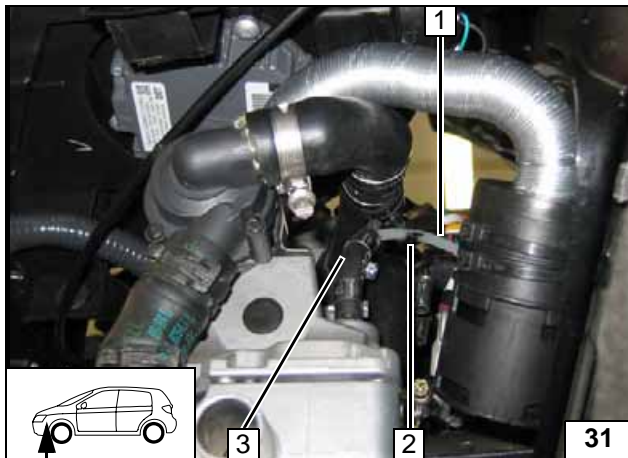

- 1 Fuel line
- 2 Hose bracket between fuel line and hose D
- 3 Hose section, 10 mm dia. clamp [2x]

**Con-
nection to
heater unit**

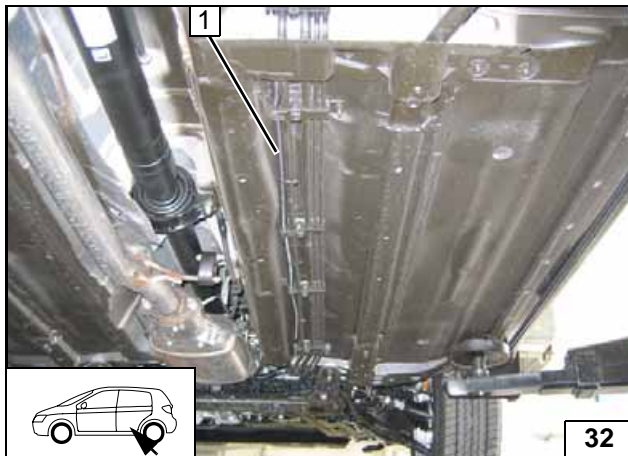

Route fuel line to right-hand side of vehicle, slide into 2x corrugated tube together with wiring harness of metering pump and route along original vehicle fuel line to installation location of metering pump.

- 1 Corrugated tube with fuel line and wiring harness for metering pump



**Installing
lines**

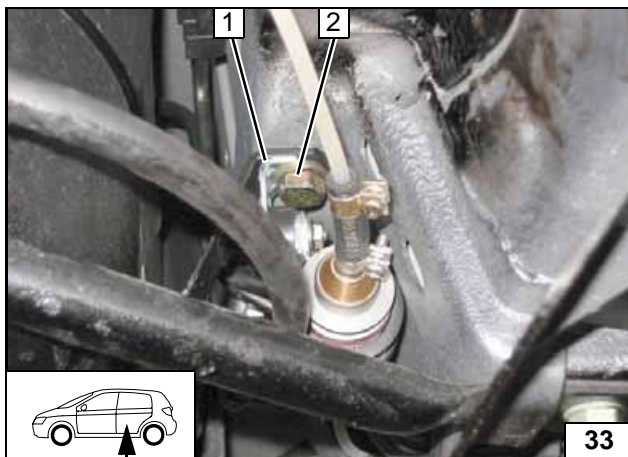

- 1 Angle bracket, hole drilled out to 10.5 mm dia.
- 2 Original vehicle bolt



**Installation
location of
metering
pump**

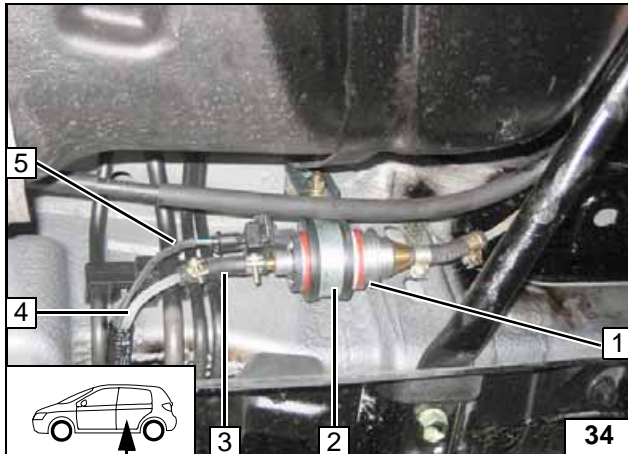

- 1 Metering pump
- 2 Rubber-coated p-clamp, silent block, flanged nut [2x]
- 3 Hose section, 10 mm dia. clamp [2x]
- 4 Fuel line
- 5 Wiring harness of metering pump, connector mounted



Installing metering pump

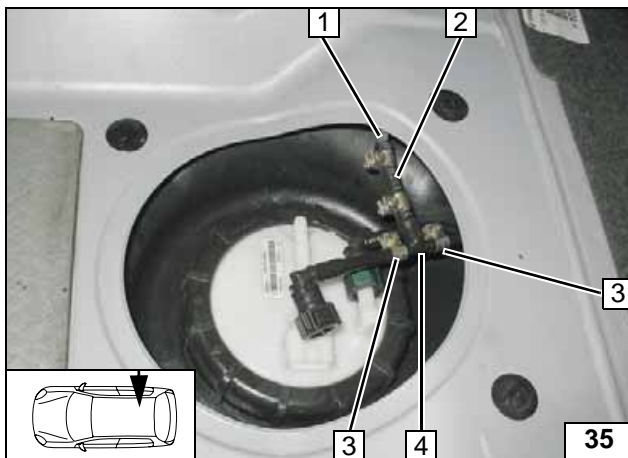

Separate fuel return line 1 approx. 50 mm before coupling.

- 1 Fuel line
- 2 Hose section, 10 mm dia. clamp [2x]
- 3 8 mm dia. clamp [2x]
- 5 6x5x6 fuel standpipe



Removing fuel

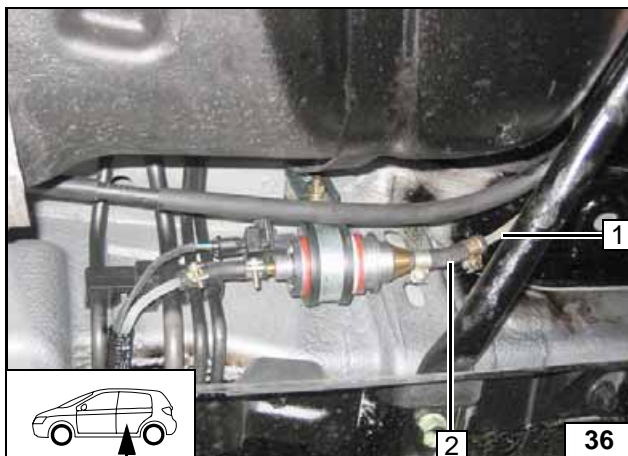

Check the position of the components; adjust if necessary. Check that they have free clearance.

- 1 Fuel line
- 2 Hose section, 10 mm dia. clamp [2x]



Connecting to metering pump

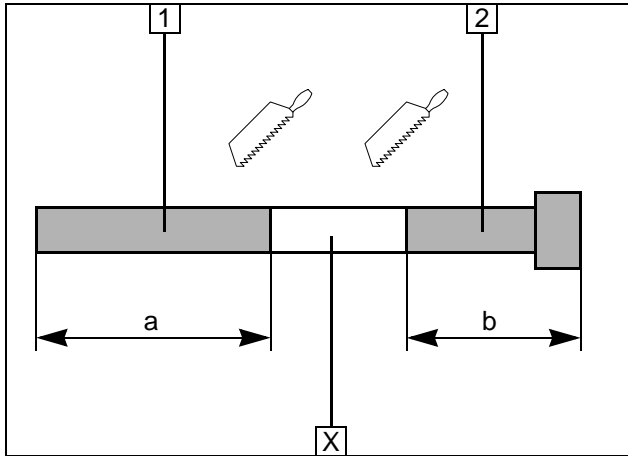
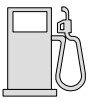

Exhaust gas

- 1 Exhaust pipe
a = 260
- 2 Exhaust end section
b = 250

Discard section X

Preparing exhaust pipe

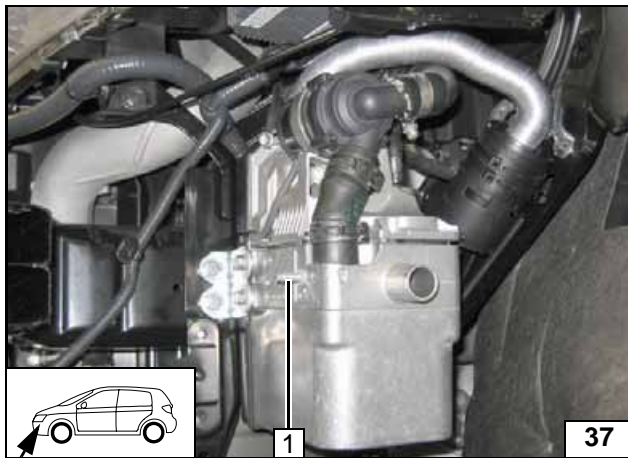

- 1 Ejet stud

Installing muffler

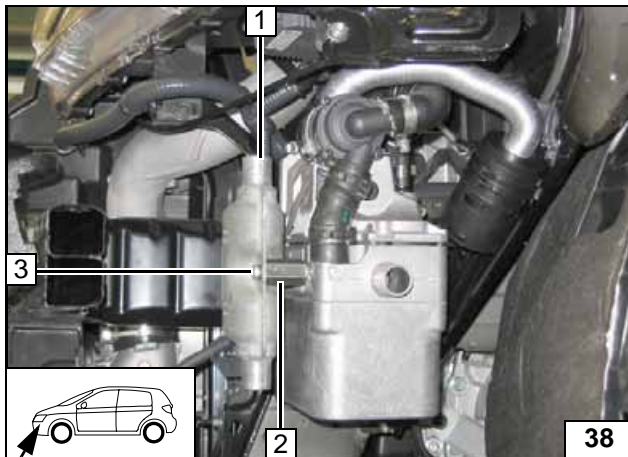

- 1 Exhaust muffler
- 2 M6x30 spacer nut
- 3 M6x12 bolt, spring lockwasher

Installing muffler

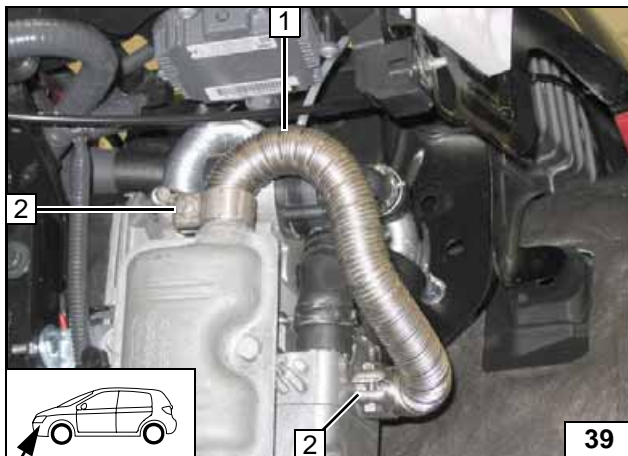

- 1 Exhaust pipe
- 2 Hose clamp [2x]

Installing exhaust pipe

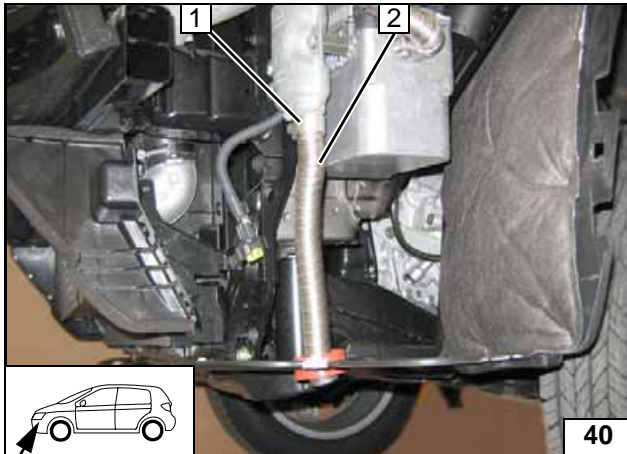
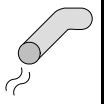

- 1 Hose clamp
- 2 Exhaust end section

Installing exhaust end section

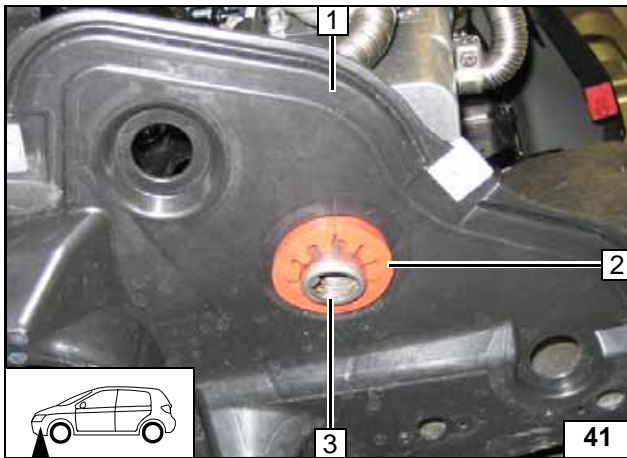

Drill out existing hole in wheel-well inner panel 1 to 42 mm dia. Insert exhaust end section 3 and red rubber isolator 2 in hole. Align exhaust end section 3 flush on red rubber isolator 2.



Mounting rubber isolator

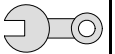

Operating Instructions for End Customer



Please remove page and add to the vehicle operating instructions.



Note:

We recommend matching the heating time to the driving time.

Heating time = driving time

Example:

For a driving time of approx. 20 min. (in one direction), we recommend not exceeding a switch-on time of 20 min.

If the summer/winter switch option has been installed, this must be switched in accordance with the time of year. The heater unit will then only switch on the vehicle fan to ventilate the vehicle interior in the position Winter  heat and in the position Summer .



Before parking the vehicle, make the following settings:

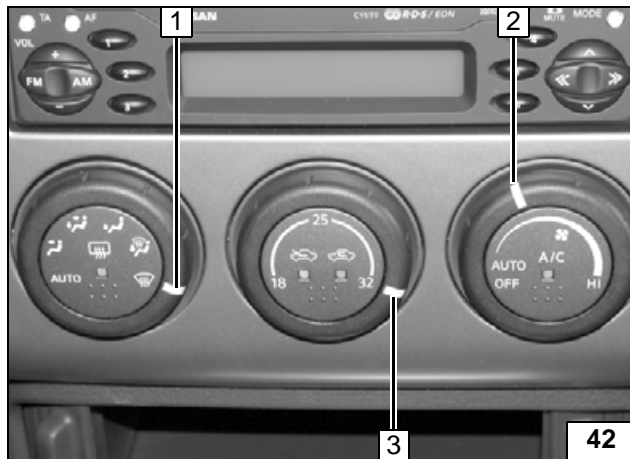

- 1 Air outlet to windshield
- 2 Adjust fan as shown
- 3 Set temperature to "max."

Automatic
air-con-
ditioning

Webasto
Feel the drive

Webasto AG
Postfach 80 - 82132 Stockdorf
Hotline 01805 / 932278 - Hotfax 0395 / 5592-353
<http://www.webasto.de>